

Strategic and Cumulative Environmental and Social Assessment

Active Turbine Management Program (ATMP) for Wind Power Projects in the Gulf of Suez

2nd Draft Report (D-5-2) on the Strategic Environmental and Social Assessment

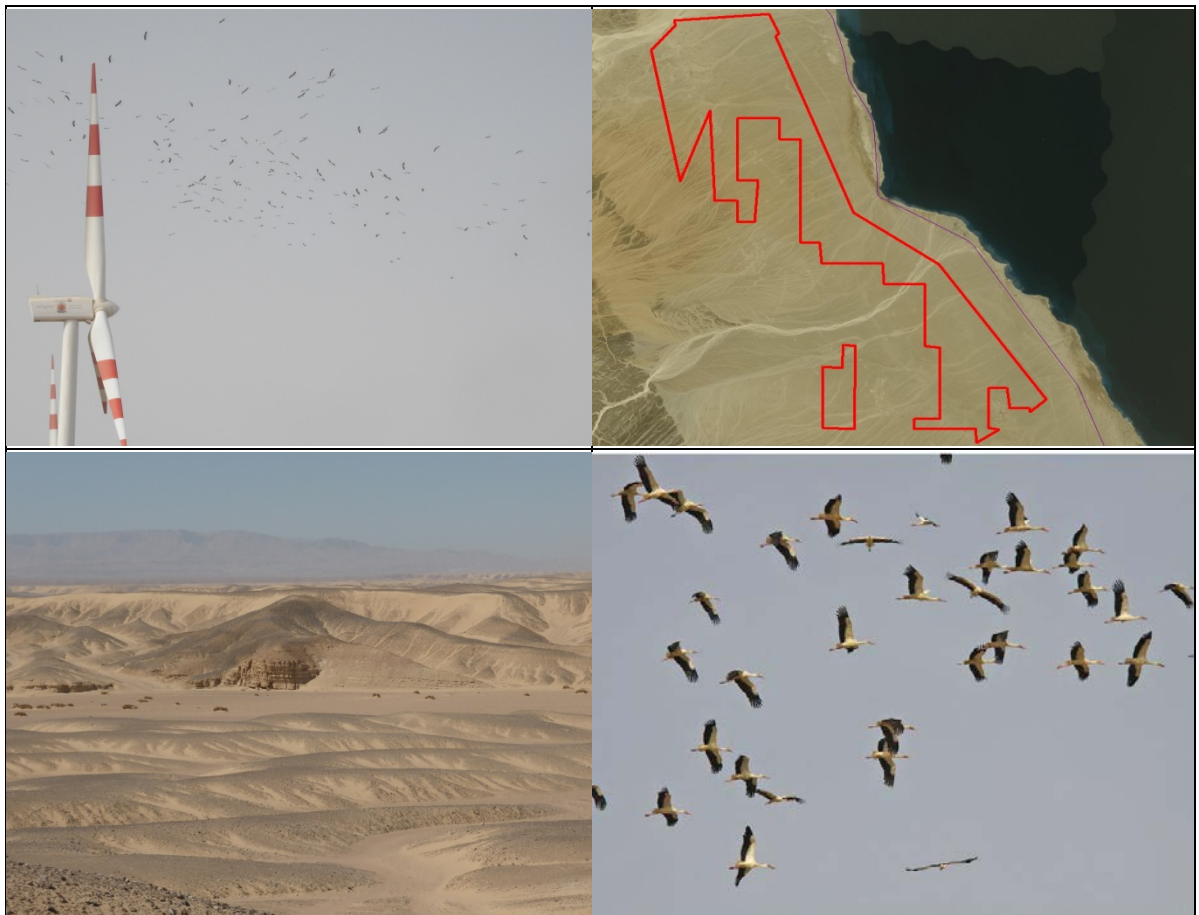

August 2017

**Strategic and Cumulative Environmental and Social Assessment
Active Turbine Management Program (ATMP)
for Wind Power Projects in the Gulf of Suez**

**2nd Draft Report (D-5-2) on the
Strategic Environmental and Social Assessment**

Prepared for:

RCREEE - Regional Centre for Renewable Energies and Energy Efficiency
Hydro Power Building, Floor 7
Block 11, Piece 15, Melsa District
Ard el Golf, Nasr City, Cairo
Arab Republic of Egypt

Prepared by

JV Lahmeyer International GmbH & ecoda Environmental Consultants GbR
c/o Lahmeyer International GmbH
Friedberger Str. 173
61118 Bad Vilbel
Germany

Report Status: **Approved**

Revision History:

Revision	Date	Author	Checked by	Approved by	Description
00	15.08.2017	V. Rashev Dr. F. Bergen	M. Drosch	M. Drosch Dr. F. Bergen	2 nd Draft SESA Report

Table of Contents

0. Non-Technical Executive Summary	1
0.1 General Introduction	1
0.1.1 Objective and Scope	1
0.1.2 The Project Area	1
0.1.3 Description of a Typical Wind Power Development in the Area	4
0.2 Existing Environment.....	5
0.2.1 Physical and Social Environment	5
0.2.2 Biological Environment	7
0.2.2.1 Protected Areas	7
0.2.2.2 Habitats.....	7
0.2.2.3 Flora and Fauna / Plants and Animals (except birds)	8
0.2.2.4 Birds.....	8
0.3 Prediction of Impacts	12
0.3.1 Physical and Social Environment	12
0.3.2 Biological Environment	15
0.3.2.1 Flora and Fauna / Plants and Animals (except birds)	15
0.3.2.2 Birds.....	15
0.4 Mitigation Measures	18
0.4.1 General Management and Mitigation - Best Practice	18
0.4.2 Management and Mitigation during Construction and Decommission	18
0.4.3 Management and Mitigation during Operation and Maintenance	19
0.4.4 Special Mitigation Measures with regards to Migrating Birds	19
0.4.4.1 Collision Risk	19
0.4.4.2 Barrier Effects	21
0.4.4.3 Post-Construction Monitoring (Risk Management).....	21
0.5 Environmental Management Plan	22
1. Project Description.....	25
1.1 Objectives and Scope	25
1.2 The Project Area	26
1.3 Description of a Typical Wind Power Project in the Area	32
1.3.1 Technical Description.....	32
1.3.2 Project Phases	37
2. Public Stakeholders and Public Involvement	40
3. Description of Institutional, Policy and Legislative Environment	41
3.1 Legislative Framework in Egypt.....	41
3.2 Applicable International Environmental and Social Standards	42
3.3 Project Categorization.....	43
3.4 ESIA and Permitting Process	43
3.5 Consideration of Alternatives and Justification of the Project	44
3.6 Main Approach.....	45

4. The Existing Environment	47
4.1 Wind Energy Potential.....	47
4.2 Physical Environment.....	49
4.2.1 Climate	49
4.2.2 Air Quality	51
4.2.3 Water Resources and Waste Water.....	52
4.2.4 Geomorphology and Soil.....	53
4.2.5 Landscape Character and Existing Views	55
4.3 Biological Environment	56
4.3.1 Data Collection.....	56
4.3.2 Protected Areas	58
4.3.3 Habitats	58
4.3.4 Flora and Fauna (except birds).....	62
4.3.4.1 Flora.....	62
4.3.4.2 Fauna (except birds)	64
4.3.5 Birds - Avifauna	67
4.3.5.1 Background, Aim and Main Approach.....	67
4.3.5.2 Methods	68
4.3.5.3 Results on Migrating Birds in Autumn	77
4.3.5.4 Results on Migrating Birds in Spring.....	100
4.3.5.5 Results on Roosting Birds	165
4.3.5.6 Results on Local Birds	168
4.4 Social Environment.....	171
4.4.1 Settlements.....	171
4.4.2 Land Use and Existing Infrastructure	171
4.4.3 Social and Economic Environment.....	172
4.4.3.1 General	172
4.4.3.2 Demographics.....	173
4.4.3.3 Labour Force	174
4.4.4 Ambient Noise Levels.....	176
4.4.5 Archaeological, Historical and Cultural Heritage	176
5. Impact Prediction and Evaluation	177
5.1 General and Basic Methodology	177
5.2 Physical Environment.....	178
5.2.1 Climate	178
5.2.2 Flash Flood	179
5.2.3 Air Quality	180
5.2.4 Water Resources and Waste Water.....	181
5.2.5 Geomorphology and Soil.....	183
5.2.6 Landscape Character and Existing Views	184
5.3 Biological Environment	187

5.3.1	Protected Areas	187
5.3.2	Habitats	187
5.3.3	Flora and Fauna (except birds).....	188
5.3.3.1	Flora	188
5.3.3.2	Fauna	189
5.3.4	Birds - Avifauna	190
5.3.4.1	Predicting and Assessing Possible Impacts on Migrating Birds	190
5.3.4.2	Predicting and Assessing Possible Impacts on Roosting Birds	196
5.3.4.3	Predicting and Assessing Possible Impacts on Local Birds.....	197
5.4	Social Environment.....	199
5.4.1	Settlements, Land Use and Existing Infrastructure.....	199
5.4.2	Impact on Traffic and Utility Services	199
5.4.3	Social and Economic Environment.....	200
5.4.3.1	Employment and Economic Effects	200
5.4.3.2	Occupational Health and Safety Risks	201
5.4.3.3	Other Socio-Economic Effects	202
5.4.3.4	Domestic and Hazardous Waste Management	202
5.4.4	Noise, Vibrations, Electromagnetic Interferences, Light Reflections and Shadowing.....	203
5.4.4.1	Noise	203
5.4.4.2	Vibrations	205
5.4.4.3	Electromagnetic Interferences	205
5.4.4.4	Light Reflections and Shadowing.....	205
5.4.5	Archaeological, Historical and Cultural Heritage	206
5.5	Cumulative Impacts.....	206
5.5.1	Definition, Difficulties and Restrictions	206
5.5.2	Wind Farm Developments to be considered	207
5.5.3	Rapid Cumulative Impact Assessment.....	211
5.5.3.1	Migrating Birds	212
5.5.3.2	Landscape and Visual Impact.....	218
5.5.3.3	Socio-Economic Impacts	218
6.	Mitigation of Environmental Impacts.....	219
6.1	Mitigation Strategy.....	219
6.2	General Management and Mitigation - Best Practice.....	220
6.3	Management and Mitigation during Construction and Decommission.....	221
6.3.1	Physical Environment.....	221
6.3.2	Biological Environment	221
6.3.3	Social and Economic Environment.....	222
6.4	Management and Mitigation during Operation and Maintenance	223
6.4.1	Physical Environment.....	223
6.4.2	Biological Environment	223
6.4.2.1	Flora, Fauna (except birds) and Habitats.....	223

6.4.2.2 Birds - Avifauna.....	223
6.4.3 Social and Economic Environment.....	233
7. Environmental and Social Management Plan	234
7.1 Environmental and Social Management	234
7.2 Monitoring Arrangements and Actions.....	237
Final Declaration	238
References.....	239
Annex.....	247

List of Figures

Figure 0.1:	Boundary Coordinates (unofficial coordinates taken from GIS) of the 284 km ² project area (above) and location of boundary points (below).....	2
Figure 0.2:	Typical Arrangement of kiosks and cabling at a wind turbine (left) and visualization of a typical wind farm in a desert area at the Red Sea coast	4
Figure 0.3:	Typical surface material in the project area: levelled desert plain in the southern part of the project area (top) and hilly terrain in the north-western part of the project area (bottom).....	6
Figure 1.1:	Topographical profiles of the project area (top: cross section through the southern part of the project area from south-west (left) to north-east (right); bottom: lengthwise cross section through the project area from north-west (left) to south-east (right) (route of sections can be taken from the Google Earth-image at the top))	27
Figure 1.2:	Impressions from the project area	27
Figure 1.3:	Boundary Coordinates (unofficial coordinates taken from GIS) of the 284 km ² project area (above) and location of boundary points (below).....	28
Figure 1.4:	Typical arrangement of wind farm siting kiosks and cabling to 220 kV substation.....	33
Figure 1.5:	Example of a typical arrangement of turbines in rows in the southern part of the 284 km ² project area (taking into consideration the provided FiT-plots).....	33
Figure 1.6:	Dimension of a typical foundation for a small wind turbine.....	34
Figure 1.7:	Example of a wind turbine foundation.....	34
Figure 1.8:	Activities due to wind turbine erection.....	35
Figure 1.9:	Typical arrangement of kiosks and cabling at each wind turbine	35
Figure 1.10:	Suez Gulf (500 MVA) 500 / 220 kV substation	36
Figure 1.11:	Typical temporary office facility at a wind farm site used during the construction phase	38
Figure 1.12:	Example for service building construction for two wind farms of about 200 MW each	38
Figure 1.13:	Typical Wind Power Project Implementation Schedule.....	39
Figure 3.1:	Typical approach of SESA/ESIA process.....	45
Figure 4.1:	Ras Ghareb wind data summary, wind rose and wind speed distribution	47
Figure 4.2:	Wind map of the project area	48
Figure 4.3:	Meteorological stations located within 200 km from the project area	49
Figure 4.4:	Wind rose at measurement mast and HURGHADA INTL station	50
Figure 4.5:	Measuring mast south of Ras Ghareb-El Shaikh Fadel road	51
Figure 4.6:	Results of the heavy flash floods occurred in late October 2016 in the project area	52
Figure 4.7:	Geological features in the project area (yellow area: Undivided Quaternary; excerpt of the Geological Map of Egypt)	54

Figure 4.8:	Typical surface material in the project area: levelled desert plain in the southern part of the project area (top) and hilly terrain in the north-western part of the project area (bottom).....	55
Figure 4.9:	Main survey routes used during site visits for baseline surveys on habitats, flora and fauna	57
Figure 4.10:	Flat and barren pebble desert in the project area (arrows point to shallow drainage lines with finer sediments).....	60
Figure 4.11:	Schematic presentation of location of lower drainage channel habitats (blue) and rocky wadi habitats (red; only outside the project area)	60
Figure 4.12:	Vegetation found in the project area on a wadi bank above flood level (left) and <i>Tamrix nilotica</i> in Wadi al-Hawwashiyah near the Suez-Hurghada road (outside the project area)	61
Figure 4.13:	Crevices at a steep slope with rocky subsoil forming potential habitats for animals (e.g. as a nesting site for local birds; right)	61
Figure 4.14:	Scattered patches of vegetation in wadis in the middle and the north of the project area	63
Figure 4.15:	Egyptian Dabb Lizard at a burrow found outside of the project area (further west) in 2013	65
Figure 4.16:	Desert White (<i>Pontia glauconome</i>) and Camel Spider (<i>Galeodes arabs</i>) found in the project area.....	66
Figure 4.17:	Experts during standardized observations in the study area.....	72
Figure 4.18:	Pole with red flag used as a landmark for estimation of distances of birds/flocks to an observation site	72
Figure 4.19:	Relative abundance (proportion in %) of all birds/records registered at distances of up to 2.5 km in different flock size classes in the study period in autumn 2016.....	78
Figure 4.20:	Relative abundance (proportion in %) of birds (orange) / records (light orange) of selected species in different flock size classes in the study period in autumn 2016.....	78
Figure 4.21:	Migratory activity (birds/h and records/h) in different weeks of the study period (September 10 th to November 10 th) in autumn 2016 (only birds at distances of up to 2.5 km to the observation sites; to correct different observational time the number of birds/records was divided by observational time of the particular week; 1 st week: September 10 th to 15 th)	79
Figure 4.22:	Average migratory activity (birds/h and records/h) at distances of up to 2.5 km to the observation sites during different periods of the day in autumn 2016 (for sites 6F and 8F (below) and for all other 12 sites (above); arithmetical mean and standard deviation; sample size (i.e. no. of observation days) for each period is given in brackets).....	80

Figure 4.23:	Comparison of migration rates (birds/h (orange) and records/h (light orange)) at the 14 observation sites in the study period (September 10 th to November 10 th) in autumn 2016 (arithmetical mean and standard deviation over all observation units; sample size (i.e. no. of observation units) at each observation site is given in brackets)	82
Figure 4.24:	Wind speed (left) and wind direction (right) obtained in the study area in autumn 2016 (ch.= changing).....	84
Figure 4.25:	Migratory activity (birds/h and records/h) in different weeks of the study period (September 26 th to November 8 th) in autumn 2015 (only birds at distances of up to 2.5 km to the observation site; to correct different observational time the number of birds/records was divided by observational time of the particular week; 1 st week: September 26 th to October 1 st).....	87
Figure 4.26:	Average migratory activity (birds/h and records/h) at distances of up to 2.5 km to the observation site during different periods of the day in autumn 2015 (arithmetical mean and standard deviation; sample size (i.e. no. of observation days) for each period is given in brackets)	88
Figure 4.27:	Wind speed (left) and wind direction (right) obtained in the Alfanar area in autumn 2015 (ch.= changing).....	89
Figure 4.28:	Migratory activity (birds/h and records/h) in different weeks of the study period (August 24 th to October 5 th) in autumn 2015 (only birds at distances of up to 2.0 km to the two observation sites; to correct different observational time the number of birds/records was divided by observational time of the particular week; 1 st week: August 24 th to 30 th).....	91
Figure 4.29:	Average migratory activity (birds/h (full orange) and records/h (light orange), respectively) at distances of up to 2.0 km to the two observation sites during different periods of the day in autumn 2015 (arithmetical mean and standard deviation).....	92
Figure 4.30:	Comparison of migration rates at the two observation sites (A (n=154) and B (n=155)) in autumn 2015 (arithmetical mean and standard deviation over all observation units; sample size (i.e. no. of observation units) at each observation site is given in brackets)	93
Figure 4.31:	Wind speed (left) and wind direction (right) obtained in the ACWA area in autumn 2015 (ch.= changing).....	95
Figure 4.32:	Relative abundance (proportion in %) of all birds/records registered at distances of up to 2.5 km in different flock size classes in the study period (April 15 th to May 25 th) in spring 2016	102
Figure 4.33:	Relative abundance (proportion in %) of birds (blue) / records (light blue) of selected species registered at distances of up to 2.5 km in different flock size classes in the study period (April 15 th to May 25 th) in spring 2016.....	102

Figure 4.34: Migratory activity (birds/h and records/h) in different weeks of the study period (April 15th to May 25th) in spring 2016 (only birds at distances of up to 2.5 km to the observation sites; to correct different observational time the number of birds/records was divided by observational time of the particular week; 1st week: April 15th to 21st) 103

Figure 4.35: Average migratory activity (birds/h and records/h) at distances of up to 2.5 km to the observation sites during different periods of the day in spring 2016 (for sites 6F and 8F (below) and for all other 12 sites (above); arithmetical mean and standard deviation; sample size (i.e. no. of observation days) for each period is given in brackets)..... 105

Figure 4.36: Comparison of migration rates (birds/h (blue) and records/h (light blue)) at the 14 observation sites in the study period (April 15th to May 25th) in spring 2016 (arithmetical mean and standard deviation over all observation units; sample size (i.e. no. of observation units) at each observation site is given in brackets) 107

Figure 4.37: Comparison of migration rates (birds/h (blue) and records/h (light blue)) at the 14 observation sites in the study period (April 15th to May 25th) in spring 2016 (median, 1st and 3rd quartile over all observation units; sample size (i.e. no. of observation units) at each observation site is given in brackets) 107

Figure 4.38: Migration rate (birds/h) and larger flocks (with > 100 birds)/h at the 14 observation sites 108

Figure 4.39: Wind speed (left) and wind direction (right) obtained in the study area in spring 2016 (ch.= changing) 111

Figure 4.40: Total numbers of birds (left) and records (right) registered in the study area during certain wind speed (above) and wind direction (below) conditions in spring 2016 112

Figure 4.41: Proportion of observational time (n=525 hours) during different wind speed (above) and wind direction (below) conditions and relative abundance (in %) of birds (n=66,212) and records (n=1,510) registered during the according wind conditions in spring 2016 113

Figure 4.42: Migration rates (birds/h and records/h) obtained during different prevailing wind regimes (low (above), medium (middle) and high (below) wind speeds in spring 2016; the observational time for each wind regime is given in brackets) 114

Figure 4.43: Relative abundance (proportion in %) of all birds/records registered at distances of up to 2.5 km in different flock size classes in the study period in spring 2017..... 117

Figure 4.44: Relative abundance (proportion in %) of birds (blue) / records (light blue) of selected species registered at distances of up to 2.5 km in different flock size classes in spring 2017 119

Figure 4.45: Migratory activity (birds/h and records/h) in different weeks in spring 2017 (only birds at distances of up to 2.5 km to the observation sites; to correct different observational time the number of birds/records was divided by observational time of the particular week; 1st week: February 20th to 22nd)..... 120

Figure 4.46: Average migratory activity (birds/h and records/h) at distances of up to 2.5 km to the observation sites during different periods of the day in spring 2016 (for sites 6F and 8F (below) and for all other 12 sites (above); arithmetical mean and standard deviation; sample size (i.e. no. of observation days) for each period is given in brackets)..... 121

Figure 4.47: Comparison of migration rates (birds/h (blue) and records/h (light blue)) at the 14 observation sites in spring 2017 (arithmetical mean and standard deviation over all observation units; sample size (i.e. no. of observation units) at each observation site is given in brackets) 123

Figure 4.48: Comparison of migration rates (birds/h (blue) and records/h (light blue)) at the 14 observation sites in spring 2017 (median, 1st and 3rd quartile over all observation units; sample size (i.e. no. of observation units) at each observation site is given in brackets)..... 123

Figure 4.49: Migration rate (birds/h) and larger flocks (with > 100 birds)/h at the 14 observation sites 124

Figure 4.50: Wind speed (left) and wind direction (right) obtained in the study area in spring 2017 (ch.= changing) 128

Figure 4.51: Total numbers of birds (left) and records (right) registered in the study area during certain wind speed (above) and wind direction (below) conditions in spring 2017 129

Figure 4.52: Proportion of observational time (n=1,351.1 hours) during different wind speed (above) and wind direction (below) conditions and relative abundance (in %) of birds (n=147,611) and records (n=3,601) registered during the according wind conditions in spring 2017 130

Figure 4.53: Migration rates (birds/h and records/h) obtained during different prevailing wind regimes (low (above), medium (middle) and high (below) wind speeds in spring 2017; the observational time for each wind regime is given in brackets) 131

Figure 4.54: Relative abundance (proportion in %) of birds/records registered at distances of up to 2.5 km in different flock size classes in the Alfanar area in spring 2016 134

Figure 4.55: Migratory activity (birds/h and records/h) in different weeks of the study period in spring 2016 (only birds at distances of up to 2.5 km to the observation site; to correct different observational time the number of birds/records was divided by observational time of the particular week; 1st week: February 27th to March 3rd) 136

Figure 4.56: Average migratory activity (birds/h and records/h) at distances of up to 2.5 km to the observation site during different periods of the day in spring 2016 (arithmetical mean and standard deviation; sample size (i.e. no. of observation days) for each period is given in brackets) 138

Figure 4.57:	Wind speed (left) and wind direction (right) in spring 2016 (ch.= changing)	139
Figure 4.58:	Total numbers of birds (left) and records (right) registered in the Alfanar area during certain wind speed (above) and wind direction (below) conditions in spring 2016	140
Figure 4.59:	Proportion of observation units with different wind speed (above) and wind directions (below) and relative abundance (in %) of birds and records registered in spring 2016 during the according wind conditions.....	141
Figure 4.60:	Relative abundance (proportion in %) of birds/records registered at distances of up to 2.5 km in different flock size classes in the ACWA area in spring 2016	143
Figure 4.61:	Migratory activity (birds/h and records/h) in different weeks in spring 2016 (only birds at distances of up to 2.0 km to the two observation sites; to correct different observational time the number of birds/records was divided by observational time of the particular week; February 27 th to March 3 rd)	145
Figure 4.62:	Average migratory activity (birds/h and records/h) at distances of up to 2.0 km to the observation sites during different periods of the day in spring 2016 (arithmetical mean and standard deviation; sample size (i.e. no. of observation days) for each period is given in brackets)	147
Figure 4.63:	Comparison of migration rates during synchronized observation units at the two sites (A (n=154) and B (n=155)) in autumn 2015 (arithmetical mean and standard deviation over all observation units; sample size (i.e. no. of observation units) at each observation site is given in brackets).....	148
Figure 4.64:	Wind speed (left) and wind direction (right) obtained in the ACWA area in spring 2016 (ch.= changing).....	149
Figure 4.65:	Total numbers of birds (left) and records (right) registered in the ACWA area during certain wind speed (above) and wind direction (below) conditions in spring 2016	150
Figure 4.66:	Proportion of observation units with different wind speed (above) and wind directions (below) and relative abundance (in %) of birds and records registered in spring 2016 during the according wind conditions.....	151
Figure 4.67:	Relative abundance (proportion in %) of birds/records registered in different flock size classes in the Lekela wind farm area in spring 2016	153
Figure 4.68:	Migratory activity (birds/h and records/h) in different weeks in spring 2016 (only birds within Lekela wind farm area; to correct different observational time the number of birds/records was divided by observational time of the particular week; February 10 th to February 16 th)	155
Figure 4.69:	Average migratory activity (birds/h and records/h) in Lekela wind farm area during different periods of the day in spring 2016 (arithmetical mean and standard deviation; sample size (i.e. no. of observation days) for each period is given in brackets)	156
Figure 4.70:	Relative abundance (%) of birds and records at different altitude classes in Lekela wind farm area in spring 2016	156

Figure 4.71:	Comparison of migration rates obtained at the two observation sites in the Lekela wind farm area in spring 2016 (arithmetic mean and standard deviation over all observation units; sample size (i.e. no. of observation units) at each observation site is given in brackets)	157
Figure 4.72:	A single Steppe Buzzard (left) and a flock of Great White Pelican (right) roosting in the desert at the Red Sea coast (outside the project area) in spring 2017	167
Figure 4.73:	Breeding site of a pair of Brown-necked Raven at a cliff west of observation site 1	170
Figure 4.74:	Areas used by the petroleum company and by Bedouins located well outside the project area	171
Figure 4.75:	220 KV overhead powerline at the eastern border of the project area (left) and track for wind farm development (right).....	172
Figure 5.1:	Assessment of significance (negligible, minor, moderate, major) as a function of receptor sensitivity and event magnitude.....	178
Figure 5.2:	Red Sea and Eastern Desert drainage system.....	179
Figure 5.3:	Visualisations of an exemplary wind farm in the desert landscape at the Red Sea coast.....	186
Figure 5.4:	Impact matrix to assess the effects of an individual wind farm in the project area on migrating birds in autumn (negligible, minor, moderate, major)	195
Figure 5.5:	Impact matrix to assess the effects of an individual wind farm in the project area on migrating birds in spring (negligible, minor, moderate, major)	196
Figure 5.6:	Noise receptors in the wider surrounding of the project area (due to the size of clusters, most receptors are not clearly shown in the map, except Ras Ghareb)	204
Figure 5.7:	Noise propagation calculation results at wind farm boundary area superposed on google earth satellite image (test configuration).....	204
Figure 5.8:	Cumulative effect of wind farm development (in the 3 rd (i.e. the most realistic) scenario)	210
Figure 5.9:	Impact matrix to assess cumulative effects of multiple wind farms in the project area on migrating birds in autumn (negligible, minor, moderate, major)	217
Figure 5.10:	Impact matrix to assess cumulative effects of multiple wind farms in the project area on migrating birds in spring (negligible, minor, moderate, major)	217
Figure 6.1:	Schematic presentation of the so-called mitigation hierarchy to be applied as a general strategy.....	219
Figure 6.2:	Schematic illustration of typical steps undertaken in an adaptive management process	228

List of Tables

Table 4.1:	Monthly averages values at the HURGHADA INTL meteorological station.....	50
Table 4.2:	List of plant species recorded during site visits in and outside the project area during site visits.....	63
Table 4.3:	List of animals (except birds) recorded during site visits or expected to occur in the project area	66
Table 4.4:	Rotation schedule applied at twelve of the 14 observation sites by two teams (MO= morning, MD= midday, A= afternoon)	69
Table 4.5:	Number of birds and records registered in the study area (i.e. at distances of up to 2.5 km from the observation sites) in the study period (September 10 th to November 10 th) in autumn 2016.....	77
Table 4.6:	Number of birds (above) and records (below) observed at distances of up to 2.5 km to the observation sites at different flight altitude classes registered in autumn 2016.....	81
Table 4.7:	Comparing migration rate (birds/h and records/h) at observation sites during synchronous observation units (results of Wilcoxon signed-rank test for paired samples: significant difference would exist, if p<0.05)	82
Table 4.8:	Number of migrating birds of species that are of minor relevance for the impact assessment or of target species that were randomly recorded in the project area	85
Table 4.9:	Number of birds and records registered in the Alfamar area (i.e. at distances of up to 2.5 km to the observation site) in the study period (September 26 th to November 8 th) in autumn 2015.....	86
Table 4.10:	Number of birds (above) and records (below) observed at distances of up to 2.5 km to the observation site at different flight altitude classes registered in autumn 2015.....	88
Table 4.11:	Number of migrating birds of species that are of minor relevance for the impact assessment recorded in the Alfamar area in the study period in autumn 2015	89
Table 4.12:	Number of birds and records registered in the ACWA area (i.e. at distances of up to 2.0 km from the observation sites) in the study period (August 24 th to October 5 th) in autumn 2015.....	90
Table 4.13:	Number of birds (above) and records (below) observed at distances of up to 2.0 km to the observation sites at different flight altitude classes registered in autumn 2015.....	92
Table 4.14:	Number of birds and records registered at distances of up to 2.0 km to the observation sites A and B in the ACWA area in autumn 2015.....	94
Table 4.15:	Migration rates recorded during autumn in different areas at the Red Sea coast (data from Bergen 2009, Bergen & Gaedicke 2013, ecoda 2007, 2011, 2016a, b).....	97
Table 4.16:	Number of birds of the most numerous species recorded in the project area in autumn 2016 and in the ACWA area in autumn 2015, respectively, and according proportion (in %) of the flyway population.....	99

Table 4.17:	Number of birds and records registered in the study area (i.e. at distances of up to 2.5 km from the observation sites) in the study period (April 15 th to May 25 th) in spring 2016.....	101
Table 4.18:	Characteristics of migration on eight days with (very) high migratory activity in spring 2016	104
Table 4.19:	Number of birds (above) and records (below) observed at distances of up to 2.5 km to the observation sites at different flight altitude classes registered in spring 2016.....	106
Table 4.20:	Number of observation units (no. obs. units) per site conducted on the eight days with the highest migratory activity (aggregating about 88 % of all recorded birds, see Table. 3.18)	108
Table 4.21:	Comparing migration rate (birds/h and records/h) at observation sites during synchronous observation units (results of Wilcoxon signed-rank test for paired samples: significant difference would exist, if $p < 0.05$)	108
Table 4.22:	Number of migrating birds of species that are of minor relevance for the impact assessment recorded in the project area in spring 2016	116
Table 4.23:	Number of birds and records registered in the study area (i.e. at distances of up to 2.5 km from the observation sites) in the study period (February 20 th to May 20 th) in spring 2017.....	118
Table 4.24:	Characteristics of migration on ten days with (very) high migratory activity in spring 2017	120
Table 4.25:	Number of birds (above) and records (below) observed at distances of up to 2.5 km to the observation sites at different flight altitude classes registered in spring 2017.....	122
Table 4.26:	Comparing migration rate (birds/h and records/h) at observation sites during synchronous observation units (results of Wilcoxon signed-rank test for paired samples: significant difference (if $p < 0.05$) are given in bold)	124
Table 4.27:	Number of migrating birds of target species recorded by chance in the project area in spring 2017.....	132
Table 4.28:	Number of migrating birds of species that are of minor relevance for the impact assessment recorded in the project area in spring 2017	133
Table 4.29:	Number of birds and records registered in the Alfanar area (i.e. at distances of up to 2.5 km to the observation site) in the study period (February 27 th and May 26 th) in spring 2016.....	135
Table 4.30:	Characteristics of migration on nine days with (very) high migratory activity in spring 2016	137
Table 4.31:	Number of birds (above) and records (below) observed at distances of up to 2.5 km to the observation site at different flight altitude classes registered in spring 2016.....	138
Table 4.32:	Number of migrating birds of target species recorded by chance or of species that are of minor relevance for the impact assessment recorded in the Alfanar area in spring 2016	142

Table 4.33:	Number of birds and records registered in the ACWA area (i.e. at distances of up to 2.0 km from the observation sites) in the study period (February 27 th and May 25 th) in spring 2016	144
Table 4.34:	Characteristics of migration on ten days with (very) high migratory activity in spring 2016	146
Table 4.35:	Number of birds (above) and records (below) observed at distances of up to 2.0 km to the observation sites at different flight altitude classes registered in spring 2016.....	147
Table 4.36:	Number of migrating birds of target species recorded by chance or of species that are of minor relevance for the impact assessment recorded in the ACWA area in spring 2016.....	152
Table 4.37:	Number of birds and records registered in the Lekela area (in the proposed wind farm area, i.e. probably FiT-plot 2-5) in the study period (February 10 th to May 15 th) in spring 2016.....	154
Table 4.38:	Number of migrating birds of species that are of minor relevance for the impact assessment recorded in Lekela wind farm area in spring 2016	157
Table 4.39:	Migration rates recorded during spring in different areas at the Red Sea coast (data from Bergen 2009, Bergen & Gaedicke 2013, ecoda 2007, 2011, 2016a, b, unpublished data).....	159
Table 4.40:	Number of birds recorded in the project area in spring 2017and according proportion (in %) of the flyway population (only species that meet the 1 %-criteria)	160
Table 4.41:	Number of birds recorded in the project area in spring 2016 and according proportion (in %) of the flyway population (only species that meet the 1 %-criteria; note that only the 2 nd half of the main migration period was covered by the survey)	160
Table 4.42:	Number of birds recorded in the Alfanar area in spring 2016 and according proportion (in %) of the flyway population (only species that meet the 1 %-criteria)	160
Table 4.43:	Number of birds recorded in the ACWA area in spring 2016 and according proportion (in %) of the flyway population (only species that meet the 1 %-criteria)	161
Table 4.44:	Number of birds recorded in the Lekela area in spring 2016 and according proportion (in %) of the flyway population (only species that meet the 1 %-criteria)	161
Table 4.45:	Exemplary approach for estimating the real numbers of White Stork migrated through an area in spring 2016 (based on the numbers recorded in different areas and on certain assumptions; note that the explanatory power of the results is believed to be very weak, as given in the text).....	163
Table 4.46:	Exemplary approach for estimating the real numbers of White Stork migrated through an area in spring 2017 (based on the numbers recorded at different observation sites in the project area and on certain assumptions; note that the explanatory power of the results is believed to be very weak, as given in the text).....	164

Table 4.47:	Number of roosting birds recorded in the project area in autumn 2016	165
Table 4.48:	Number of roosting birds recorded in the project area in spring 2016	166
Table 4.49:	Number of roosting birds recorded in the project area in spring 2017	166
Table 4.50:	Number of local birds recorded in the project area in autumn 2016	168
Table 4.51:	Number of local birds recorded in the study area in spring 2016.....	169
Table 4.52:	Number of local birds recorded in the project area in spring 2017	169
Table 4.53:	Estimated population and their percentage distribution by sex in 2016 (CAPMAS)	173
Table 4.54:	Population in governorates (urban/rural) according to final results of 2006 population census (CAPMAS)	173
Table 4.55:	Birth, mortality and natural increase rates by governorate (urban/rural) 2014 (rate: per 1,000 of Population). (Vital Statistics, Egypt in figures 2016, CAPMAS).....	173
Table 4.56:	Administrative and municipal sections in Red Sea Governorate (Statistical Yearbook-Housing 2014, CAPMAS)	173
Table 4.57:	Number of schools in Red Sea Governorate (2014 and 2016, CAPMAS).....	174
Table 4.58:	Population and Educational status (Statistical Yearbook-population, 2006 census CAPMAS).....	174
Table 4.59:	Estimated of employed persons by sex and industry in Red Sea Governorate 2014 (Statistical Yearbook – Labor, CAPMAS)	175
Table 5.1:	Assumed water quantity during the construction	182
Table 5.2:	Classification of four different zones of potential visual impact (depending on the distance to the receptor).....	185
Table 5.3:	First scenario (simultaneous construction) of cumulative effects of wind farm development.....	207
Table 5.4:	Second scenario of cumulative effect of wind farm development	209
Table 5.5:	Third scenario of cumulative effect of wind farm development	209
Table 6.1:	Details of an appropriate SOD-program to reduce collision risk for large soaring birds during spring migration	226

List of Maps

Map 0.1:	Location of the project area	3
Map 0.2:	Overview of the location and bordering of project area, observation sites and study area	10
Map 1.1:	Location of the project area	29
Map 1.2:	Boundaries of the project area.....	30
Map 1.3:	Existing and proposed infrastructure associated with wind farm development	31
Map 4.1:	Northern part of the important bird area (IBA) “Gebel el Zeit” (EG031) - nominated by BirdLife International	59
Map 4.2:	Overview of the location and bordering of project area, observation sites and study area	70
Map 4.3:	Mean migration rate of target species (birds/h) at the 14 observation sites and flight paths of Great White Pelicans and White Storks in autumn 2016	83
Map 4.4:	Mean migration rate of target species (birds/h) obtained by different surveys in spring 2016.....	109
Map 4.5:	Flight paths of Great White Pelican and White Stork during the study period in spring 2016.....	110
Map 4.6:	Mean migration rate of target species (birds/h) obtained at observation sites in the project area in spring 2017	125
Map 4.7:	Absolute number of birds and relative abundance of target species at each observation site	126
Map 4.8:	Flight paths of Great White Pelican and White Stork during the study period in spring 2017.....	127
Map 5.1:	Wind farm developments to be considered in the cumulative impact assessment	208
Map 5.2:	Schematic illustration of likely flight paths of target species in autumn under the precondition of barrier effects caused by large wind farms	215
Map 5.3:	Schematic illustration of likely flight paths of a nameable portion of target species in spring under the precondition of barrier effects caused by large wind farms	216
Map 6.1:	Schematic illustration of likely flight paths of a nameable portion of target species in spring after under consideration of the proposed mitigation approach	231

List of Annexes

- Annex I: Target species, which are known to migrate along Egypt
- Annex II: Explanation of different categories of “The IUCN Red List of Threatened Species” for migratory bird species in Egypt
- Annex III: List of experts who were involved over large periods in the monitoring of migratory soaring birds
- Annex IV: Species factsheets for autumn and spring migration
- Annex V: Numbers of birds/records (rec) registered at the 14 observation sites (1 to 14) in
- a. autumn 2016
 - b. spring 2016
 - c. spring 2017
- Annex VI: Potential effects of operating wind farms on migratory soaring birds
- Annex VII: “Sensitivity Search” by application of the Soaring Bird Sensitivity Map Tool (BirdLife International)

Abbreviations

a.s.l.	Above sea level
CAA	Competent Administrative Authority
EA	Environmental Assessment
EC	European Commission
EEAA	Egyptian Environmental Affairs Agency
EEHC	Egyptian Electricity Holding Company
EETC	Egyptian Electricity Transmission Company
EA	Environmental Assessment
EIA	Environmental Impact Assessment
EIB	European Investment Bank
EMP	Environmental Management Plan
EU	European Union
GoE	Government of Egypt
GPC	General Petroleum Company (or Corporation), Ministry of Petroleum
GUPCO	Gulf of Suez Petroleum Company
HV	High Voltage
HT	High Tension (e.g. 220 kV)
IFC	International Finance Corporation
KV	Kilovolt
LC	Local currency (EGP)
LDC	Load Dispatch Centre
LT	Low Tension
MEE	Ministry of Electricity and Energy
MOP	Ministry of Oil and Petroleum
MT	Medium Tension (e.g. 22 kV)
MW	Megawatt
NREA	New and Renewable Energy Authority
OHL	Overhead Line
RCREEE	Regional Centre for Renewable Energy and Energy Efficiency
TL	Transmission Line
WTG	Wind Turbine Generator

0. Non-Technical Executive Summary

0.1 General Introduction

0.1.1 Objective and Scope

For an area of about 284 km² (project area) about 5 km inland from the shores of the Gulf of Suez located north-west of Ras Ghareb likely environmental and social impacts of future wind farm developments have to be studied. The objective of wind power utilisation in this area is to

- make use of the excellent wind power potential at the site, and at the same time
- substitute oil and gas for electricity generation and to save indigenous fuel resources, and safe CO₂ emissions.

The assessment of environmental and social impacts caused by wind power development is targeting to

- determine any likely significant impact caused by wind power development in the area;
- assess, whether such impacts can be mitigated or whether they require a restriction or a cancellation of wind power development;
- define eventually necessary mitigation measures and environmental and social management (ESM) requirements; and
- assess the effects of possibly required mitigation and ESM measures with regard to the overall viability of wind power development in the area.

This SESA Report follows the Egyptian Environmental laws, regulations and guidelines. At the same time it is considered that the minimum standards of the Equator Principles are kept. This is to fulfil the financing conditions of major international financing institutes that have committed themselves to keep the Equator Principles as minimum environmental standards.

Major elements of the assessment were field surveys such as general area reconnaissance, ornithological field monitoring over three migration periods (spring 2016, autumn 2016 and spring 2017) and a survey on flora and fauna (others than avifauna).

0.1.2 The Project Area

The project area is located in the most north-eastern part of the Eastern Desert which extends between the Nile Valley and the Red Sea. The Eastern Desert is traversed by numerous depressions (wadis) running to the Red Sea or to the Nile Valley. The wadis crossing the project are dewatering directly to the East, to the Red Sea.

The project area is located on the western bank of the Gulf of Suez, about 150 km north of Hurghada. Minimum distance to the next settlement, Ras Ghareb, is less than 10 km (see Map 0.1). It consists of two sections. The larger section has a length of about 43.0 km from north-west to south-east. The width (from west to east) varies between 10.0 and 1.5 km. Furthermore an isolated section, with a length of about 7.5 km from north to south and ca. 2.5 km from west to east, exists west of the southern part of the above-named larger section (coordinates are given in Figure 0.1). The Red Sea stretches from north-west to south-east at distances of 3.0 to 5.0 km to the eastern boundary of the project area. The Red Sea Mountains run from northwest to southeast at a distance of at least 10 km to the western boundary of the project area.

The project area is rather flat and consists of gravel and pebbly plains and is almost completely without vegetation. Smaller wadis with sparse vegetation cross the project area on their way from the Red Sea Mountains (in the west) to the Red Sea (in the east).

No.	Point	Coordinates, UTM Zone 36 R		No.	Point	Coordinates, UTM Zone 36 R	
		Easting, m E	Northing, m N			Easting, m E	Northing, m N
1	B1	470570.77	3176148.23	25	B25	481954.00	3156315.31
2	B2	477968.15	3176711.97	26	B26	480498.75	3156334.58
3	B3	478807.22	3174960.75	27	B27	480465.05	3165577.44
4	B4	478503.61	3174686.11	28	B28	478820.07	3165564.58
5	B5	484594.86	3159004.38	29	B29	478813.65	3165583.86
6	B6	491293.31	3154397.30	30	B30	478807.25	3167392.68
7	B7	499707.32	3142340.15	31	B31	475549.59	3167392.62
8	B8	498348.35	3141540.20	32	B32	475556.03	3161863.60
9	B9	496806.21	3141530.54	33	B33	477168.75	3161857.25
10	B10	496632.76	3143342.54	34	B34	476898.98	3158201.20
11	B11	495187.14	3143361.76	35	B35	475549.60	3158175.46
12	B12	495109.95	3139776.45	36	B36	475523.91	3160064.51
13	B13	495967.65	3139660.81	37	B37	473768.20	3160051.25
14	B14	494232.96	3138485.03	38	B38	473406.80	3168089.38
15	B15	494136.58	3139728.26	39	B39	471079.19	3161800.68
16	B16	489336.81	3139709.02	40	B40	468787.08	3173470.46
17	B17	489346.42	3140586.07	41	B41	470710.33	3175715.13
18	B18	491322.19	3140605.28	42	B42	482171.27	3145260.11
19	B19	491360.74	3146956.83	43	B43	483700.06	3145162.62
20	B20	490223.50	3147082.13	44	B44	483797.63	3147179.29
21	B21	490223.48	3152585.39	45	B45	484741.01	3147114.21
22	B22	486994.74	3152701.07	46	B46	484643.43	3139697.80
23	B23	486908.05	3154474.70	47	B47	482203.86	3139795.39
24	B24	482117.86	3154503.40				



Figure 0.1: Boundary Coordinates (unofficial coordinates taken from GIS) of the 284 km² project area (above) and location of boundary points (below)

Map 0.1
Location of the project area

project area
 project area

● editor: Lars Gaedicke, July 31st 2017

0 150 km

 1:3.000.000



Content may not reflect National Geographic's current map policy. Sources: National Geographic, Esri, DeLorme, HERE, UNEP-WCMC, USGS, NASA, ESA, METI, NRCAN, GEBCO, NOAA, increment P Corp.

0.1.3 Description of a Typical Wind Power Development in the Area

The final design of wind power development in the project area would be known after detailed planning of each individual successful Bidder of the Fit land plots. Thus, the detailed design will very much depend on the wind turbine type and capacity, which will be selected in a tender process. Therefore, at this stage potential environmental impacts have to be assessed for typical wind park layouts.

Typical features of wind power projects in a homogenous area with pre-dominant wind direction are outlined below. The design lifetime of a wind power plant is about 20 years. Wind power will be developed perpendicular to the predominant wind direction in southwest to northeast rows at distances of about 700 to 1100 m between rows and distances of about 200 to 300 m between turbines within a row.

Wind turbines with unit capacity of about 2.0 MW to 4.0 MW, rotor diameters of 70 to 110 m and max tip heights of about 120 m are likely to be selected. Other typical features of such a project are the wind turbine foundations of about 2 to 3 m depth and a surface of up to 17 x 17 m² in case of a large turbine (3.0 to 4.0 MW), wind turbines with tubular towers with diameters of up to 4.5 m at the footing and maximum blade tip heights of about 120 m (allowing wind turbine unit capacities of up to about 4.0 MW). The wind farm internal grid consists of cable trenches and small electrical kiosks next to each wind turbine (see Figure 0.2) comprising of ring main unit and possibly as well transformer and/or controller stations, if the latter will not be integrated into the turbines. Other major features are the wind farm internal gravel roads of about 5 m width and erection platforms of 1,000 to 2,000 m² at each wind turbine.



Figure 0.2: Typical Arrangement of kiosks and cabling at a wind turbine (left) and visualization of a typical wind farm in a desert area at the Red Sea coast

The wind power collected by the MT cable grid has to be evacuated via 220/22 kV substations and 220 kV OHL to the 500/220 kV substation being under construction in the south of the project area near to the crossing asphalt road. Accordingly, two central 220/22 kV substations at the border of the project area are considered for evacuation of the wind power to the 500/220 kV substation under construction. The exact position of these 220/22 kV substations will depend on the later clustering of the project area and the installed wind power on these clusters. Moreover, at this stage of project preparation it is assumed that service areas (for control and maintenance including spare part and tools stock) will be built at the border of the area, e.g. near to a 220/22 kV substation, and near Suez-Hurghada road or in Ras Ghareb, with access to the LT network.

Only very limited land on a wind farm site is affected by construction works. The construction area per MW installed is estimated to be 3,900 m². Thus, usually 2 % of a wind farm area is directly affected by construction works.

In addition, service and control room facilities will be required. Control may take place by remote control routed through a central wind farm server. Such wind farm server may be established in a small container within the wind farm site next to a wind turbine or within a 220/22 kV onsite substation. Service and storage facilities with accommodation facilities of different investors will most likely be installed outside the project area in reach of water and electricity supply, e.g. in the outskirts of Ras Ghareb.

Usually such service installations consist of an apartment building, a central facility (conference room, mosque and cantina), spare part and consumable storage premises (e.g. 30 x 20 m), an open storage area and a small control and office building. Water will have to be provided by tanker or through interconnection to the water supply system. The number of persons living and working in the area in shifts to operate and maintain the wind farms would be not more than 30 for a wind farm size of about 200 MW. I.e. the total number of personnel for operation and maintenance of wind farms is estimated to be about 220.

Further installations associated to the wind farm would be two HT/220/22 kV substations in the project area and a short 220 kV overhead power line to the 500/220 kV substation located south of the project area next to Ras Ghareb – El Shaikh Fadel road. As such interconnection will be built especially for wind power development in the project area, it is considered as part of the project.

0.2 Existing Environment

0.2.1 Physical and Social Environment

Climate

The climate is dominated by a wind circulation system from northern high pressure to southern low pressure systems all over the year, causing wind blowing from northerly directions. Due to the channel effects of the Red Sea and the Sinai mountains the strength of the winds is enforced and the direction is pronounced. Accordingly, in the project area the dominant wind direction is from northwest in parallel to the mountain ranges. Winds are stronger and more stable blowing from northwest during summer, when the pressure gradients are more pronounced. During winter, winds may turn to the south during some days.

Average maximum Temperature	30° C (January) to 46 °C (August)
Average Temperatures	16.3° C (January) to 32.5° C (August)
Average wind speed at 10 m	about 6 m/s
Maximum Gust	about 35 m/s
Rainfall	very sporadic, hyper arid area

Air quality

The area is a desert area and due to the strong winds the dust is lifted and is contained in the air. No emissions, which can affect the air quality are inside the project area. No impact of acidic emissions due to the sulphate of flare gas from the GPC oil field is expected, due to the strong wind and the large distance.

Water resources and waste water

No sources of groundwater are available in the project area. On rare occasions, intense but short-lived cloudbursts sometimes result in significant surface runoff in wadis drainage large catchment areas. Some of these surface flow events may rarely develop into flash floods. The ground water is more than 100m below the surface. No activities using water or water drainage in the project area

Geomorphology and soil

The project area is located in the Gulf of Suez coastal plain near Ras Ghareb. The coastal Plain forms a relatively flat strip of land between the basement and sedimentary reliefs of Mount Ghareb and El Galala El Qibliya in the west and the Gulf of Suez coast in the east. The plain is covered with undivided Quaternary deposits, consisting of wadi and playa deposits or raised beaches and varies in width between 25 and 30 km and has a relatively simple topography, with a generally gentle slope towards the sea. The frequency of shallow earthquake occurrences is low.

Landscape character and existing view

The landscape shows typical desert area without any specific features. The project area is characterized with levelled desert plain in the south and with hilly terrain in the north west



Figure 0.3: Typical surface material in the project area: levelled desert plain in the southern part of the project area (top) and hilly terrain in the north-western part of the project area (bottom)

Settlements

The project area and its surrounding area is an uninhabited, undeveloped desert land. Except for the town of Ras Ghareb, about 8 km southeast of the site with around 60,000 inhabitants, no permanent settlements are found in the entire area. At least one Bedouin family is settled in the Red Sea area, approx. 25 km south of the project area

Land use and existing infrastructure

The project area is currently undeveloped and is not under any type of land use. Two roads used by petrol companies are crossing the project area, as well as 220 kV OHL is located in the eastern part of the project area. Single tracks were constructed due to the wind farm development as well as tracks of 4x4 cars are an indicator for rare usage of the project area. A several oil production installations are scattered throughout the surrounding of the project area, gas pipelines, mobile telecommunication mast, military post are found adjacent to the project area. The Ghareb Sheikh Fadl and the Suez-Hurghada roads are running south and east of the project area respectively, as well as several private roads and tracks serving oil installations, as well as single tracks built for the wind farm development are the only infrastructure elements in the surrounding area. No public water and electricity distribution system exist.

Social and economic environment

Main economic activity in the area is the crude oil production. Tourism is not well developed at the area of Ras Ghareb area comparing with other part of Egypt. The unemployment in the area is comparatively low for the Egypt.

Ambient noise level

During the frequent strong winds a natural high noise level appears, no noise emission in the area except from minor traffic passing on the asphalt road used by the petrol companies

Archaeological, historical and cultural heritage

No protected areas, historical or archaeological sites are found at or near the project area.

0.2.2 Biological Environment

0.2.2.1 Protected Areas

The investigation reveals that there are no national parks or other designated protected sites in the project area (e.g. EEAA 2015, Fouda 2006).

However, in the south-east a small part of the project area overlaps with the so-called "Gebel el Zeit" area (EG031) which was nominated as an Important Bird Area (IBA) by BirdLife International (see Map 4.1; BirdLife International 2017).

0.2.2.2 Habitats

Due to the extreme aridity the vast majority of the project area (even most parts of the wadis) is completely without vegetation and do not serve as a suitable habitat for plants. These areas have a very low to no importance as a habitat for plants and a very limited importance as a habitat for animals.

Caves form particular structures in the desert that offer important habitats for animals (e.g. as shelter). At single locations in the northern part of the project area small caves or crevices occur. Those plots are assessed to have an importance as a habitat for animals, e.g. as a shelter against the sun or as a nesting site for local birds.

0.2.2.3 Flora and Fauna / Plants and Animals (except birds)

Vegetation cover in the project area was found to be extremely sparse and restricted to single drainage channels. Vegetation within the project area generally has a low species composition, density and a very patchy distribution. The wadis tend to support the most vegetation due to generally higher soil moisture levels. Permanent plants can only be found in

- smaller wadis crossing the project area from west to east in its northern part;
- Wadi Um Tinassib in the middle of the project area (near observation sites 10 and 11; see Chapter 4.3.4.2 and Map 4.2); and
- Wadi al-Hawwashiyah in the southern part of the project area (near observation site 12).

Plants found in the project area were mostly limited to very sparse communities of *Ochradinus baccatus* and *Zygophyllum coccineum*. *Stipagrostis plumose* was observed in the southern part of the project area. No tree or larger bush occurs within the project area.

All species found within the project area are common and widespread in the Eastern Desert and, thus, not believed to be endangered or threatened. However, the conservational status of the mentioned species has not yet been assessed by an international or national Red List.

Few numbers of mammal, reptile and invertebrate species were recorded in the project area. Most species are quite common throughout the Eastern Desert. The only species of conservational concern is the Egyptian Dabb Lizard that is considered to be “Vulnerable” (according to IUCN Red List of Threatened Species). In addition, the Egyptian Dabb Lizard is formally protected by Egyptian legislation, and so are Rüppell's Sand Fox, Egyptian Jackal and Cape Hare. None of the other species recorded during site visits or expected to occur in the project area are known to be endangered or threatened. The area seems to be a rather suitable site for some reptile species of which most are quite common and widespread. For other species, the habitat potential of the project area is rather limited.

0.2.2.4 Birds

Background and Objectives

Parts of the Gulf of Suez, especially the area near Gabel el Zayt, are well known as a bottleneck for migrating birds from Europe and western Asia. Installing large wind farms in this region may lead to significant impacts on migrating birds caused by collisions with wind turbines or - to a lower degree - by barrier effects. In addition, large wind farms might even affect roosting and local (i.e. breeding) birds by direct habitat degradation or indirect disturbance (due to avoidance behaviour of birds).

On that background an extensive monitoring on birds was conducted in accordance with the EIA guidelines and monitoring protocols for wind energy development projects in Egypt. The monitoring aimed to collect baseline data on large soaring birds (mainly storks, pelicans and raptors (“target species”)), roosting and local birds. On that basis likely impacts caused by multiple wind-farm projects within the 284 km² area can be identified and assessed and appropriate mitigation measures minimizing impacts can be defined.

Methods

The bird monitoring (ornithological survey) that focused on bird migration took place during three different periods and lasted from April 15th to May 25th, 2016 (spring migration and breeding period), from September 10th to November 10th, 2016 (autumn migration), and from February 20th to May 20th, 2017 (spring migration and breeding period).

The investigation on migrating birds was based on standardized observations using fixed observation sites. With regard to the extent of the project area, a total of 14 observation sites were selected to obtain a representative sample of migration of large soaring birds within the project area (see Map 0.2). Observations were conducted by three teams - each with two ornithologists - and covered 35 days (525 hours) in spring 2016, 54 days (950.3 hours) in autumn 2016 and 77 days (1,351.1 hours) in spring 2017. A chief ornithologist advised and supervised the ornithologists.

In addition, in spring and summer 2017 combined transect-/point-counts with mainly direct observations were conducted to collect data on the occurrence of roosting and breeding birds. Therefor an expert slowly drove with a 4x4 Land Cruiser along the selected transects in search of present birds. At certain locations the surrounding was “scanned” with a binocular. Moreover, during all site visits (i.e. systematic transect counts, standardized and non-standardized observations) every observation of resting or local birds was recorded (number of individuals, species, sex, behaviour).

Additional baseline data on the occurrence of migrating, roosting and local birds was made available from other investigations that took place in smaller plots located within the project area in 2015 and 2016 (see Map 0.2: Alfamar area, ACWA area, Lekela area).

Autumn Migration – Results and Assessment of the Importance of the Project Area

During standardized observations in autumn 2016 a total of 2,437 birds from 23 target species were recorded in the study area. European Honey Buzzard, White Stork and Great White Pelican were the most numerous species, representing about 91 % of all registered individuals. None of these species is considered as to be “Critical Endangered”, “Endangered”, „Vulnerable“ or “Near Threatened” (according to the IUCN Red List of Threatened Species).







The results of all available investigations reveal that migratory activity of target species in the project area is low during the autumn season. Remarkable migratory activity was restricted to single days and mainly referred to larger flocks that can be regarded as rare events. On that background the project area is not particularly important for autumn migration of target species. This conclusion is in accordance with the general idea of bird migration at the Red Sea in autumn.

Spring Migration – Results and Assessment of the Importance of the Project Area

During the investigation a total of 66,211 (spring 2016) and 147,611 (spring 2017) birds from 26 and 27 target species were observed in the study area. In 2016, White Stork, European Honey Buzzard, Steppe Buzzard, Great White Pelican and Black Kite were the most numerous species, representing 97 % of all registered individuals. White Stork made up about 69 % of all registered birds. In 2017, White Stork, Steppe Buzzard and European Honey Buzzard were the most numerous species (90 % of all registered individuals). White Stork made up about 63 % of all registered birds.

Though migration of target species was low during some periods, a very high migratory activity was obtained on single days. Relevant numbers of “Endangered” or “Vulnerable” species occurred in the study area, in particular Steppe Eagle with 4,740 individuals in spring 2017. More than 1 % of the flyway population of ten target species was observed in the whole study area and even at single observation sites. Hence, the project area is located in or near an important migration route for large soaring birds in spring and is clearly of high importance for large soaring birds in spring (especially if it is considered that the recorded numbers present only a sample of the overall bird migration).

Map 0.2
Overview of the location and bordering of project area, observation sites and study area

- Project Area**
-  boundaries of the project area
 -  existing roads
- Study Areas**
-  observation site
 -  RCREEE study area
 -  Alfamar area
 -  ACWA area
 -  Lekela area (exact bordering unknown)

● editor: Lars Gaedicke, July 31st 2017

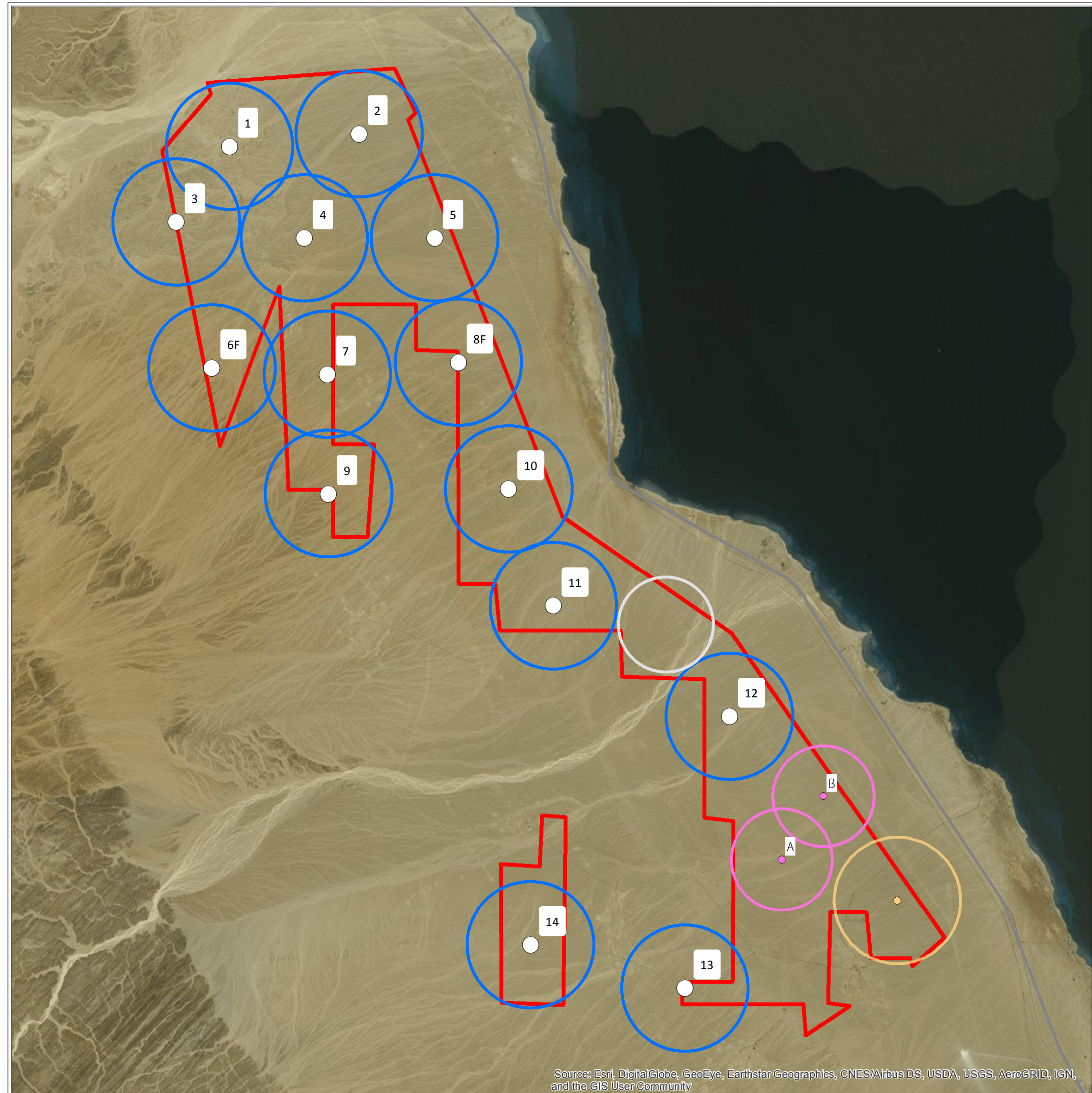
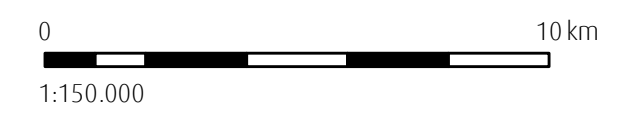

Migratory activity at the 14 observation sites was highly variable and strongly affected by few large flocks which are rare events and can be recorded at every individual site. The results obtained in spring 2016 and 2017 do not support the assumption of the existence of preferred flight paths that are regularly (i.e. every spring) used or of certain areas with lower migratory activity. There are no remarkable topographic features which affect the spatial distribution of large soaring birds over the desert coastal plains northwest of Ras Ghareb in spring. Consequently, no spatial differentiation can be made when describing and assessing migratory activity in the project area. Hence, the importance of each individual FIT-plot for spring migration of large soaring birds has to be assessed as high, too.

Roosting Birds – Results and Assessment of the Importance of the Project Area

The results of the available investigations consistently reveal that target species rarely use the project area as a roosting habitat. Considering the high numbers of birds that cross the area during spring migration season, the number of roosting birds observed in the project area was very low. Most birds were recorded in the early morning clearly indicating that these birds obviously spend a single night in the desert before continuing migration. In times of bad weather conditions (e.g. during sand storms which rarely occur) target species might stop migration and go down on the ground even during daytime. There are no spots that were preferred by target species as a roosting site. In fact, the project area does not offer special habitat features (like sebkhas) that are particularly suitable for large soaring birds. To conclude, the importance of the project area as a roosting site for large soaring birds is low. Particularly raptors are believed to mainly roost and spend the night in the Red Sea Mountains.

Most non-target species (predominately songbirds) were found in the wadis that hold small patches of vegetation which offer shelter against the sun during the day. Those wadis can be regarded as a suitable roosting site for small songbirds. Nevertheless, the number of recorded birds was small. Hence, the importance of the project area as a roosting site for non-target species is low.

The project area does not hold any important roosting site for birds.

Local Birds – Results and Assessment of the Importance of the Project Area

Only very few species inhabit the project area and use it as a breeding site (e.g. Spotted Sandgrouse, Brown-necked Raven and Larks), which are widespread in (northern) Africa. Due to the hyper-arid climate, the harsh wind conditions and - probably most important - the lack of vegetation bird density of breeding species is very low. Other species visit the project area occasionally and use it as a hunting (e.g. Common Kestrel) or foraging area (e.g. Crowned Sandgrouse) in low numbers. Apart from Sooty Falcon (“Near Threatened”) all other species are classified as to be of “Least Concern” in the IUCN Red List of Threatened Species.

Specific features, like cliffs and vegetated spots, might have an ecological function as breeding, foraging or resting habitat for the few local species. However, the importance of the project area as a habitat for local birds is very low. The project area does not hold any important breeding site for birds.

0.3 Prediction of Impacts

0.3.1 Physical and Social Environment

The expected impacts can be summarised as follows:

Air quality

Construction and decommission activities (e.g. demolition, completion of ground works) for wind farms and associated infrastructure have the potential to affect air quality due to the dust. As far as necessary and reasonable, dust control measures shall be considered to minimize the possible impact. In addition, construction plants and vehicles can locally and temporarily affect air quality as a result of exhaust emissions.

No dust and gaseous emissions will originate from wind farms and/or associated infrastructure during operation.

Water resources and waste water

There will be no direct discharge to groundwater or surface water (which only rarely occurs in the wadis after heavy rainfall) during construction / decommission activities. However, as a result of accidents, those activities have the potential to release pollutants to the ground and, hence, to the groundwater and / or surface water. Measures will be implemented to reduce the risk posed by these potential sources of pollutants.

Water supply during the construction / decommission phase will be usually via tankers from the central pipeline. Waste water will be collected at site and will be removed from site for treatment at an appropriate treatment facility.

No liquid emissions will originate during the operation phase of wind farms and the associated infrastructure. Waste water (from the service facilities, e.g. staff and management building) will be collected at site and will be removed from site for treatment at an appropriate treatment facility. Waste water will not be discharged to either groundwater or surface water.

Geomorphology and soil

Construction activities will result in adverse changes of land cover and in a compaction of soil in affected areas. This impact will remain for the whole operation and maintenance phase. Construction impacts on land cover will occur within relatively small areas and usually cover only about 2 % of the project area.

During the whole project cycle there will be no direct discharge to the ground (topsoil, subsoil and natural strata). However, as a result of accidents, construction/decommission and maintenance activities have the potential to release pollutants to the ground. Measures will be employed to reduce the risk posed by the potential sources of pollutants.

Landscape and visual impact

Wind farms in the project area will result in a negative change in landscape character during construction phase due to the increased 'urbanisation' associated with activities such as the movement of crane vehicles for the delivery and installation of turbines and erection of electricity pylons and buildings within a more or less untouched desert area. However, these activities will occur within a rather short period of time.

The prominence and operation of a huge number of wind turbines (incl. support infrastructure) and will cause a negative change to the landscape character in the project area and its surrounding. This

is due to the introduction of tall vertical, industrial structures in a predominantly low and open landscape which can be characterized as a more or less untouched desert area. The turbines will become a dominant feature and a key characteristic of the landscape within the area. As a result the project will cause an adverse impact on the landscape character. However, one has to consider that there are no people living or regularly visiting the area that might be negatively affected by the project. Few facilities of the petrol company are located within an area of high visual impact (mainly at the southern border of the project area) and other facilities in an area of moderate impact. The Suez-Hurghada road runs for about 45.0 km through an area of moderate impact.

Land use

As there will be only a minor land take (about 2% of the project area) and in the absence of ecologically sensitive habitats, attractive landscape, antiquities, agriculture, residents etc. the minor land take has not any significant impact. The impacts easily can be further reduced by avoidance of spots of residual vegetation. The above is valid for both, the construction and the operation phase.

Traffic and utility services

Construction activities for wind farm developments will result in an increase in vehicular traffic including movement of construction vehicles. The project area can be reached from the Suez-Hurghada road. This road has sufficient strength and width and would be suitable for heavy transport. To conclude, as the main roads in the overall region are very well dimensioned at low traffic frequency there are not any critical impacts on the traffic on public roads during construction or decommission phase.

A considerable amount of water might be required for concrete making for turbines, pylons and buildings, if the concrete will not be provided as ready mix. In case of having a batching plant at the site the water will have to be provided by tankers. With a maximum demand of 50 m³ fresh water per day the nearby water supply systems might already be stressed. If that water cannot be provided from the public utility sources it must be procured from the Nile Valley by tankers, what is still manageable.

There will be no water demand of wind farms themselves during operation. Some water demand may arise from the sanitary facilities of staff building and substation (about 1 m³/d). The facilities might be connected to the regional water supply originating from the Nile via Hurghada. The expected amount of water consumption will not be critical for the supply of the region.

Socio-economic effects

The construction of wind farms will offer significant employment opportunities to local personal. About 30 to 40 % of the investment volume would be produced locally. The operation of wind farms will make use of indigenous resources and helps to safe oil and gas resources. Moreover, wind power generation will help to reduce CO₂ emissions (about 1,890 t CO₂/MW/year).

Occupational health and safety risks

There are significant safety risks during the construction phase resulting from earth and concrete works, the erection works (working at heights), handling of heavy equipment and electrical installations. During the operation phase such risks origin from the maintenance works in wind farms. The risks can be reduced to acceptable level, if keeping internationally accepted health and safety standards.

Noise

The only sensitive noise receptors in the region are the residents of Ras Ghareb being approx. 8 km away from the border of the project. At such distances noise from wind farms is not perceivable.

Vibration

During both, the construction and operation phase, no significant impacts from vibration is expected. Vibrations resulting from wind turbines working under regular conditions show very little vibration with the blades correctly balanced and the main shaft correctly adjusted. The propagation of the vibration is dampened by the foundation body and there is very little transmission into the underground, especially in case of a non-rocky underground like in the subject project area. Thus, vibration effects will not be measurable in the underground already nearby wind turbines.

Electromagnetic Interferences

Wind turbines could potentially cause electromagnetic interference with aviation radar and telecommunication systems (e.g. microwave, television, and radio). The nature of the potential impacts depends primarily on the location of the wind turbine relative to the transmitter and receiver.

A military radar is operated south of the project area. As the area was already cleared by the Ministry of Defense before being assigned for wind power development by presidential decree, it can be assumed that no interference with wind farm developments is expected.

One mobile phone telecommunication mast and one radio link mast are placed at the Ras Ghareb-El Shaikh Fadel road southwest of the project area. Due to the large distance of at least 9 km wind farm developments should not block any signal from any directional transmitters.

Under consideration of keeping sufficient corridors and safety distances no relevant adverse impact on electromagnetic systems such as radar, telecommunication and television broadcast is expected.

Light reflection and shadowing

The blade coating of modern turbines does usually absorb direct sun light and, thus, reflection does not cause any environmental impact.

The critical impact of shadowing (flickering) as per acceptable standards is 30 hours per year and 30 minutes per day. This can be achieved only at places near to wind turbines, where the observed transition time of the sun through the rotor diameter can achieve such durations. As there are no residences or housing near to the turbines, it is obvious that there is no impact from flickering beyond acceptable level.

Archaeological, historical and cultural heritage

In the absence of archaeological, historical and cultural heritages within the projects area or in its wider surrounding no adverse impact caused by wind farm developments is expected.

0.3.2 Biological Environment

0.3.2.1 Flora and Fauna / Plants and Animals (except birds)

Plants

The land-use by wind farm developments is very limited (usually about 2 % of the overall area) leaving most of the area free from any interventions. Consequently, the affected area will cover only a small fraction of project area. No turbine will be installed inside larger wadi beds. Construction measures in the wadis will be limited to single crossing by gravel roads and by cable trenches carried out at less sensitive spots. In conclusion, construction of wind farms within the area will cause no significant impacts on vegetation or plant communities.

Operating wind turbines are not known to affect plants or plant growth. During periods of maintenance of wind farms human activities will be restricted to the already existing tracks and storage positions. In conclusion, operation and maintenance of wind farms within the area will cause no significant impacts on vegetation or plant communities.

Animals

The local animal communities have very few species. Moreover, density is very low. Compared to the whole project area, the area required for infrastructural structures is very small. Thus, even after turbine erection there will be enough appropriate habitats available for local animals. In summary, the impact on animals caused during construction phase is not assessed as relevant.

Noise and shading resulting from operating turbines is limited in space and time. Hence operating wind farms are not expected to impact animal wildlife significantly. In conclusion, operation and maintenance of wind farms within the area will cause no significant impacts on animals.

0.3.2.2 Birds

Bird-wind turbine interactions

Considering installation of large wind farms in the project area, the major potential hazards to birds are additional mortality caused by collision and barrier effects. Other possible impacts of wind turbines, probably of minor importance, might be displacement due to disturbance or direct habitat change and loss for roosting or local birds.

Assessment of impacts on during the construction phase

Birds in active flight (migrating birds) will not be affected during the construction phase. Noise and dust emission at distinct construction sites might bring migrating birds to alter their flight path, but this has to be regarded as a negligible impact.

Construction of wind farms might lead to a modification or a loss of habitat for local or roosting birds by using areas for foundation of turbines, permanent access roads, storing positions for heavy machines, other technical installations etc. However, the area required for infrastructural elements is comparatively small in relation to a single FiT-plot and - all the more - in relation to the whole project area. Thus, even after construction of wind turbines birds will find sufficient opportunities for roosting, breeding and foraging. Human activities during construction might disturb roosting or local birds. However, such disturbance effects are restricted to a small area and appear only temporarily. To conclude, construction of wind farms in the project area might lead to minor impacts on roosting and local birds, because

- the area was rarely used by roosting birds and does not hold a preferred roosting site;
- the local bird community is very poor in species and, moreover, bird density is very low; and

- the space required for infrastructure which might be temporarily affected by human disturbance during construction is, in relation to the whole project area, low.

Assessment of impacts during the operation and maintenance phase on migrating birds

Migrating birds might be affected by collision leading to an additional mortality or by barrier effects during operation and maintenance phase:

As the project area is not of particular importance for large soaring birds during autumn migration, collision risk at an individual wind farm and at multiple wind farms in the project area is not assumed to pose a major threat for large soaring birds in autumn. Single collisions at wind farms in the project area might occur even during autumn migration, but the expected collision rate will not cause significant effects on populations of migrating birds and is, thus, not assessed as a significant impact. Nevertheless, this assessment shall be verified by a thorough post-construction monitoring at operating wind farms. Furthermore, general mitigation measures shall be applied to reduce collision risk as much as possible.

By contrast, very high numbers of large soaring birds have been recorded in the project area in spring. Consequently, collision rates leading to additional mortality potentially causing significant population effects for some species cannot be excluded when operating an individual wind farm in the project area. This applies particularly to Steppe Eagle, but also to Great White Pelican, White Stork, European Honey Buzzard, Black Kite, Egyptian Vulture, Short-toed Snake Eagle, Levant Sparrowhawk and Booted Eagle. Hence, appropriate mitigation measures and a thorough post construction-monitoring are required for each individual wind farm to reduce the risk of collision to an acceptable level. All the more significant adverse effects on populations must be expected when operating multiple wind farms within the project area. Hence, substantial efforts are strictly required to reduce the risk of collisions of large soaring birds at multiple wind farms in spring.

While avoidance behaviour reduces collision risk, it could result in wind farms acting as barriers to bird movement. Migrating soaring birds might change their horizontal flight direction in order to avoid a wind farm or they might change (most probably increase) flight altitude enabling them to subsequently migrate over the critical zone of wind turbines. Although the degree of additional energy expenditure caused by these reactions cannot be estimated precisely, it seems unlikely that avoidance behaviour triggered by an individual wind farm might produce a significant effect on populations. Consequently, any impact caused by barrier effects at a single wind farm is assessed as negligible in the autumn season (when migratory activity is comparably low) and as moderate in the spring season.

When considering multiple wind farms in the project area barrier effects might provoke complex and critical situations that can hardly be predicted. However, due to the comparable low migratory activity in autumn barrier effects are regarded as a minor to medium impact even when considering multiple wind farms. No residual significant adverse impact on migrating birds is expected during the autumn season and, hence, no further management and mitigation (except from applying best practice procedures and general mitigation measures) is required.

By contrast, in spring when very high numbers of target species cross the project area barrier effects might lead to major (significant) impacts on large soaring birds. For instance, large soaring birds might

- face the risk of being drifted off to the sea by strong winds from north-western directions after having changed the flight direction to the northeast;

- get trapped by wind farms in the west, in the north and in the east and, thus, might be forced to undertake enormous effort to escape this situation;
- even stop migration; and
- face an increased risk of collision at one wind farm after having avoided another wind farm.

To sum up, bearing in mind the uncertainty of predictions application of the precautionary principle and implementation of appropriate mitigation measures is strictly advisable in order to reduce the potential of adverse barrier effects, which may interact with collision risk or even increase collision risk, caused by multiple wind farms on large soaring birds in spring.

Assessment of impacts during the operation and maintenance phase on roosting birds

It is well known that species which tend to roost in larger flocks avoid operational wind turbines. Hence, roosting birds might be affected by disturbance effects during the operational phase of wind farms in the project area. However, such effects are assessed as a minor impact, because the area was rarely used by roosting birds and does not hold a preferred roosting site. Moreover, even after construction of large wind farms there remain undisturbed areas that can be used for roosting by birds.

This is valid for disturbance effects caused by human activities related with maintenance of wind farms, too. Such effects are restricted to a small area and appear only temporarily and are, thus, assessed as a minor impact on roosting birds.

As the project area was rarely used by roosting birds and does not hold a preferred roosting site, collision risk at wind farms in the project area is assessed as a minor impact on roosting birds. Moreover, species roosting in larger flocks usually avoid wind farm areas and will not roost in the vicinity of turbines.

To conclude, no significant impact on roosting birds is expected during the operation and maintenance phase of large wind farms in the project area.

Assessment of impacts during the operation and maintenance phase on local birds

Disturbance by operational turbines leading to a decrease in habitat quality or a total habitat loss is assessed as a minor impact, because the local bird community is very poor in species and bird density is very low. Moreover, most species (as local birds) are known to be unsusceptible to the nearly constant acoustic and visual stimuli of wind turbines. Thus, even after construction of wind turbines birds will find sufficient opportunities for breeding and foraging inside and outside wind farm areas.

Disturbance effects caused by human activities related with maintenance of wind farms are restricted to a small area and appear only temporarily. In addition, the local bird community is very poor in species and as bird density is very low. Hence, disturbance by human activities during the operation and maintenance phase is assessed as a minor impact on local birds.

Local birds will also face the risk of collision at operating wind turbines. However, resident birds are aware of turbines and their behaviour might be better adapted to the presence of these infrastructures. As the local bird community is very poor in species, as all species are widespread in (northern) Africa and as bird density is very low, collision risk at large wind farms in the project area will not lead to adverse population effects and is, thus, assessed as a minor impact on local birds.

To conclude, no significant impact on local birds is expected during the operation and maintenance phase of wind farms in the project area.

0.4 Mitigation Measures

0.4.1 General Management and Mitigation - Best Practice

The following management and mitigation measures can be regarded as a best practice standard that shall be applied under any condition and during any project phase (construction, operation, maintenance and decommission):

- All activities must be restricted to the boundaries of the construction areas, storage positions and access roads / tracks. Any use of the surroundings must be strictly avoided.
- Supplying or changing oil, lubricant or hydrocarbon to vehicles shall be done in gas stations and not on site. Strict control must be applied by a site supervisor. Contingency measures and plans for spill removal must always be ready on site.
- Waste has to be removed immediately and has to be safely stored at the site so that drifting is avoided.
- Awareness programmes to personnel shall be carried out. Behavior and attitude of involved personnel during field activities shall be controlled by a site supervisor.
- Potential occupational health and safety hazards during the construction phase shall be controlled by appropriate measures.
- The contractor shall provide effective protection for land and vegetation resources at all times and shall be held responsible for any subsequent damage.
- The contractor shall be forced to good workmanship and housekeeping during construction by contractual stipulations and by assignment of supervising engineers in order to assure adequate disposal of solid waste and waste water, to avoid or to collect spillages of used oils, greases, etc.
- The contractor shall be forced not to leave the construction site unless the area was put into tidy conditions, excavations are backfilled, heaps of excavation material is leveled and waste is adequately disposed of.
- Avoid establishing spots (waste dump, open water bodies, gardens or houses with vegetation) that might attract animals.
- Ban killing, hurting and unnecessary disturbing (incl. relocation) of any wildlife elements in the project area.

0.4.2 Management and Mitigation during Construction and Decommission

Except from applying best practice procedures during construction and decommission the following management and mitigation is required:

- Standard dust control measures that are commonly used on construction sites shall be implemented to minimize the impact on air quality.
- Waste water shall be collected at site and shall be removed from site for treatment at an appropriate treatment facility.
- Relevant occupational health and safety standards shall be considered and compliance with the standards shall be controlled during the construction / decommission of wind energy projects.
- The littering of waste and the spillage of hazards shall be avoided by proper workmanship and strong supervision.

To mitigate impacts on migrating, roosting and local birds caused by large wind farms in the project area the following general measures should already be considered in the planning and construction phase:

- Avoid turbines with lattice towers.
- Paint turbine blades to increase blade visibility.
- Restrict turbine height to a reasonable maximum total tip height (about 120 m), as collision risk for migrating birds is believed to increase with turbine height.
- Avoid lighting of wind turbines, as birds might be attracted to wind farm areas by lights leading to an increased collision risk.
- Build the grid within a wind farm area and the grid between different wind farm areas by underground MT cables.

Furthermore, development of wind turbines in the eastern part of FiT-plot 3-4, which overlaps with the Important Bird Area Gebel El Zeit, needs to be discussed amongst relevant stakeholders.

0.4.3 Management and Mitigation during Operation and Maintenance

Sanitary waste water shall be collected at site and shall be removed from site for treatment at an appropriate treatment facility. Measures shall be implemented to reduce the risk of contamination of water resources and soil posed by potential sources of pollutants (such as fuels, oils, chemicals and associated liquid waste materials) during the operation and maintenance phase.

Except from applying best practice procedures and general mitigation measures during operation and maintenance no further management and mitigation is required with regards to flora and fauna and habitats, because no significant adverse impacts are expected by the operation/maintenance of wind farms and associated infrastructure in the project area.

Relevant occupational health and safety standards shall be considered and compliance with the standards shall be controlled during the operation/maintenance of wind farms and associated infrastructure in the project area (e.g. IFC 2007).

The littering of waste and the spillage of hazards shall be avoided by proper workmanship and strong supervision.

In the event that the aforementioned management and measures will be implemented no significant adverse impacts are expected by the operation/maintenance of wind farms and associated infrastructure in the project area.

0.4.4 Special Mitigation Measures with regards to Migrating Birds

0.4.4.1 Collision Risk

In order to reduce collision risk for large soaring birds at an individual wind farm during spring migration an effective shutdown program has to be established. Therefor two alternate approaches are possible:

- Fixed shutdown (FS) program

If applying a FS-program all turbines of a wind farm shall be stopped during the critical migration period in spring (i.e. March 1st to May 18th) during daytime (i.e. 1.5 hour after sunrise to 1.5 hour before sunset).

- Shutdown on-demand (SOD) program

When applying a SOD-program selected turbines are stopped in times of high collision risks, i.e. during periods of high migratory activity or when large flocks approach a wind farm. A SOD-program has already been implemented at two large wind farms located about 40 km south(east) of the project area. During execution of these SOD-programs four criteria for triggering the shutdown of turbines have been applied:

1. Threatened species
2. Flocks with 10 or more large soaring birds (target species)
3. Imminent high risk of collision
4. Sand storms

The results gained at the two wind farms indicate that the SOD-program has been an efficient and successful measure leading to a low number of collision victims (even though a small number of birds collided) and to short periods of shut downs. Hence, the criteria for shutting down times used at the two wind farms shall act as a starting point for a large wind farm in the project area. The criteria shall then be fine-tuned through an adaptive management approach resulting from on-going monitoring and benefiting from the experience obtained during the first seasons. An appropriate approach for a SOD-program at a large wind farm in spring and details important for the implementation of such a program are given in Table 5.1.

It should be pointed out that the SOD-program offers the opportunity to operate a wind farm even during the migration season in spring when several ten thousands of large soaring birds cross the project area. Thus, the approach helps to maximize the energy yield of an individual wind farm and to increase the benefit for the owner, even though execution of the SOD-program will cause additional cost. Choosing the alternate option, i.e. a fixed shutdown of wind turbines for a period of 79 days in spring, would lead to an immense decrease of the yearly energy yield of a wind farm.

It is obvious that the risk of collision will increase with the number of operating wind farms. Hence, implementation of a SOD-program is strictly required for each individual wind farm in every FiT-plot. In doing so, even multiple wind farms are unlikely to cause significant population effects on target species. However, a rather low and - after having applied mitigation measures - acceptable risk caused by each individual wind farm might add up to a serious threat for species when considering multiple wind farms. To ensure that such cumulative impacts can be thoroughly considered during the operational phase of multiple wind farms it is crucial to implement an adaptive management process covering the following steps:

- Design and implement appropriate mitigation measures for each individual wind farm.
- Conduct a thorough post-construction monitoring (see below) at each individual wind farm.
- Evaluate the effect of all wind farms on the basis of the results of the post-construction monitoring.
- Adjust mitigation measures (if necessary) to avoid significant adverse population effects.

Operation of wind farms within the project area shall be harmonized and coordinated in order to secure that the additive mortality imposed on bird populations remain at a non-critical level. The experience gained by SOD-programs and the conclusions obtained by post-construction monitoring need to be shared among key stakeholders. It is obvious that this cannot be handled by a developer or owner of a single wind farm. Hence, harmonization and coordination of wind farm operation and guiding the adaptive management process needs to be arranged and accompanied by responsible authorities (most probably by NREA).

To facilitate the complex adaptive management process following a step-wise approach seems to be a reasonable option. If, for instance, ten wind farms with a total of 500 MW will be developed in a first phase, the experiences gained with the SOD-program during the first years can be considered in a second and third development phase. As the findings of executed SOD-programs allow calculating the yearly energy loss caused by shutdown periods, the step-wise approach might even minimize the financial risk for developers and investors.

0.4.4.2 Barrier Effects

A significant impact on migratory soaring birds during spring migration cannot be excluded when operating multiple wind farms in the project area calling for specific mitigation measures.

Though barrier effects might be stronger at operating wind farms, shutting down turbines (as designed to reduce collision risk) does not seem to be an applicable mitigation measure in this case, because migratory soaring birds might avoid large non-operating wind farms, too. In addition, barrier effects might appear at a larger scale, i.e. at larger distances to a wind farm and, thus, before a shutdown is initiated. Assuming such macro-avoidance behaviour of migrating soaring birds, large wind farms have the potential to negatively affect the ecological function of an area as a migration corridor.

To efficiently reduce potential barrier effects of multiple wind farms in the project area it is recommended to keep sufficient space between wind farms enabling large soaring birds to safely migrate over the coastal desert plains northwest of Ras Ghareb and to continue migration further north in spring. This can only be achieved by a ban of wind farm development in single FiT-plots. From a strict technical point of view the most appropriate approach is to waive installation of wind farms in FiT-plot 4-1, 8-1, 1-2, 2-2, 1-4 and in the western part of FiT-plot 1-1, in the south-western part of FiT-plot 7-1 and in the north-eastern part of FiT-plot 3-2 (partly located in the 300 km² area) (see Map 6.1). Applying this approach no significant residual impacts on large soaring birds during spring migration (with regards to barrier effects) are expected by multiple wind farms in the remaining FiT-plots. Though there might be other options (i.e. other FiT-plots affected by a ban of developments) the proposed approach seems to be the most efficient one. It will even lead to a reduction of collision risk at wind farms in the remaining FiT-plots and will probably shorten shut down periods at these wind farms.

Again, conducting a post-construction monitoring will be crucial to ensure that the proposed approach meets its goals. Based on the results of the post-construction monitoring one can decide whether additional measures are necessary or additional wind farms can subsequently be developed in the selected FiT-plots (if the monitoring reveals that barrier effects are remarkably lower than assumed in the impact assessment).

0.4.4.3 Post-Construction Monitoring (Risk Management)

Bearing in mind the uncertainty of predictions and the importance of the Red Sea coast for bird migration execution of a comprehensive post-construction monitoring programme for each individual wind farm (in each FiT-plot) is crucial to ensure that the shutdown programme and all other mitigation measures are thoroughly established and meet their goals and to decide whether additional measures are required to minimize or eliminate unacceptable impacts. The post-construction monitoring shall comprise

- standardized carcass searches at wind turbines during spring migration period (from March 1st to May 18th) and during autumn migration period (from August 20th to September 20th); and

- standardized observations of bird behavior (incl. flight paths) in the vicinity of wind turbines during spring migration period (from March 1st to May 18th) to assess the frequency of critical situations and to identify conditions under which critical situations occur (if so).

0.5 Environmental Management Plan

The implementation of mitigation measures require actions during the bidding, planning, construction and post-construction phase for each individual wind farm that will be erected in an accepted plot. These actions can be summarized in the following Environmental and Social Management Plan (ESMP).

Project activity	Environmental Concern	Mitigation Measures	Estimated Cost (EUR)
Bidding and planning phase	Health and safety risks	Make keeping standards as defined in the “Environmental, Health and Safety Guidelines for Wind Energy” (IFC 2007) a minimum obligation in the Tender Documents	To be included in the investment cost
		Make the assignment of a health and safety engineer during the construction process a condition	To be included in investment cost
		Make a health and safety plan for the construction site obligatory	To be included in investment cost
		Make provision of safety tools and equipment as per accepted standards by the contractor a bidding condition	To be included in investment cost
	Important Bird Area Gebel El Zeit	Development of wind turbines in the eastern part of FiT-plot 3-4 needs to be discussed amongst relevant stakeholders	No additional cost
	Birds	Ban wind farm development in FiT-plots 1-4, 1-2, 2-2, 4-1, 8-1 and in parts of FiT-plots 1-1, 3-2 and 7-1	No additional cost
		Avoid turbines with lattice towers	No additional cost
		Limit maximum tip height of wind turbines (about 120 m)	No additional cost
		Paint turbine blades to increase blade visibility	About 10,000 € per MW; to be considered in investment cost
		Avoid establishing spots that might attract birds	No additional cost
		Each developer shall be bindingly committed to align with the “adaptive management program” and to strictly follow the recommended measures during all project phases	No additional cost
		Harmonize and coordinate installation and operation of multiple wind farms in the project area	No additional cost
		Build internal grid as underground cable	To be considered in investment cost

Project activity	Environmental Concern	Mitigation Measures	Estimated Cost (EUR)
Detailed planning and construction phase	Health and safety risks	Availability of an adequate health and safety plan	To be included in investment cost

Project activity	Environmental Concern	Mitigation Measures	Estimated Cost (EUR)
Construction phase	Health and safety risks	Assignment of health and safety engineer of Contractor with independency with regard to giving health and safety instructions.	Included in investment cost
		Keeping the “Environmental, Health and Safety Guidelines for Wind Energy “(IFC 2007) as a minimum condition.	Included in investment cost
		Availability and proper utilisation of safety tools and equipment.	Included in investment cost
		Hygienic temporary sanitary facilities.	Included in investment cost
		Assure stoppage of erection works during weather conditions beyond safety limits.	Included in investment cost; extended erection periods
	Pollution	Good workmanship and housekeeping to be assured by supervising engineers to assure adequate disposal of solid waste and waste water and to avoid or to collect spillages of used oils, greases, diesel, etc.	Included in investment cost
		At the end of construction works: Force the contractor to put the construction site into tidy conditions, to backfilled excavations, to level heaps of excavation material and to dispose off waste adequately.	Included in investment cost
	Flora, fauna (except birds) and habitats	Restrict all activities to the boundaries of the construction areas, storage positions and access roads/tracks. Any use of the surroundings must be strictly avoided.	Very limited additional cost for investors, that can be quantified after detailed design is done only
		Avoid establishing spots that might attract animals.	No additional cost
	Birds	Restrict all activities to the boundaries of the construction areas, storage positions and access roads/tracks. Any use of the surroundings must be strictly avoided.	Very limited additional cost for investors, that can be quantified after detailed design is done only
		Avoid establishing spots that might attract birds.	No additional cost
		Build internal grid as underground cable.	To be considered in investment cost

Project activity	Environmental Concern	Mitigation Measures	Estimated Cost (EUR)
Operation and maintenance phase	Health and safety risks	Assure that operation and maintenance at wind turbines is carried out by personnel only that have passed a safety training course.	Standard requirement to be observed by project owners and monitored by a qualified external expert (50,000 EUR for a larger wind farm)
	Birds	Execution of an effective SOD-program at each individual wind farm in spring to reduce collision risk for large soaring birds.	175,000 € to 200,000 € per 50 MW wind farm and year
		Avoid or minimize lighting of wind turbines.	No additional cost
		Avoid establishing areas that might attract birds.	No additional cost
		Carry out a comprehensive post construction bird monitoring at each individual wind farm for at least the first three years during spring (carcass searches and standardized observations) and autumn (carcass searches only) to identify any impacts on migrating birds beyond acceptable level and to apply additional mitigation measures or improve already established mitigation measures, wherever necessary, to the limits defined in this study (adaptive management).	375,000 € to 400,000 € per 50 MW wind farm for three years (can probably be reduced if two or three 50 MW wind farms will be surveyed synchronously)
		Conduct yearly workshops to share data and experiences with regards to the SOD-program and the post-construction monitoring at each individual wind farm. Jointly discuss the conclusions and the need for further mitigation measures or adjustments.	To be considered by each individual owner or to be covered by responsible authorities
	Pollution	Assure proper management of domestic waste at service buildings and of used grease and oils (recycling).	Standard requirement to be observed by owners

Project activity	Environmental Concern	Mitigation Measures	Estimated Cost (EUR)
Decommission phase	Land-use and landscape	Remove the wind turbine installations at the end of the life time.	To be borne by the investor and to be considered in the investment cost

1. Project Description

1.1 Objectives and Scope

The Arabic Republic of Egypt has developed an ambitious plan to increase the contribution of renewable energy to 20 % of the electricity generated by the year 2022, of which 12% of wind power plants is foreseen, mostly in the Gulf of Suez due to the excellent wind characteristics in the area. The Government of Egypt (GoE) has allocated approximately 284 km² of land about 5 km inland from the shores of the Gulf of Suez and to the north-west of Ras Ghareb that shall be used for developing multiple wind-farm projects. This land is portion of a 1,229 km² area allocated for wind power utilisation by presidential decree No. 168 of May 13th, 2009. The objective of wind power utilisation in this area is to

- make use of the excellent wind power potential at the site, and at the same time
- substitute oil and gas for electricity generation and to safe indigenous fuel resources, and safe CO₂ emissions.

This Strategic Environmental and Social Assessment (SESA) follows the Egyptian Environmental laws, regulations and guidelines and complies with Egyptian E&S Policy (2014), with European Union Strategic Environmental Assessment Directives, with Egyptian Law no. 4/1994 for the Protection of the Environment Amended by Law 9/2009 complemented by the 2010 EIA guidelines issued by the Egyptian Environmental Affairs Agency (EEAA) and with the Environmental Impact Assessment Guidelines and Monitoring Protocols for Wind Energy Development Projects along the Rift Valley/Red Sea Flyway (EEAA 2013).

At the same time it is considered that the minimum standards of the Equator Principles are kept. This is to fulfil financing conditions of relevant international financing institutes that have committed themselves to keep the Equator Principles as minimum environmental standards.

Major elements of the assessment were field surveys such as general area reconnaissance, ornithological field monitoring over three migration periods (spring 2016, autumn 2016 and spring 2017) and a survey on flora and fauna (others than avifauna).

RCREEE is managing the process of conducting the Strategic and Cumulative Environmental and Social Assessment, while project development and coordination is done by NREA. The area was proposed by the National Centre for Land-use Planning and was approved by the Council of Ministers. Thus, it can be assumed that assessment of alternatives had already been considered during the pre-planning stage.

The area shall be split into different individual project zones. The final configuration is subject to further planning and contracting considering requirements as stipulated in this SESA Report. Although individual projects are not yet definitely defined, a good description of future wind farm developments is possible as wind power projects in such mostly flat areas with predominant wind direction follow typical configuration principles. Thus, it is one objective of this study to describe future wind power projects in the area as realistic as possible to limit additional efforts for getting the environmental permit for the individual projects to be implemented later-on.

This SESA Report focuses on the environmental and social assessment and the identification of necessary avoidance and mitigation measures. For this assessment typical wind farm layout for the project areas under consideration is assumed. Thus, a layout of future arrangement as realistic as possible is carried out to consider any eventual environmental and social impacts resulting from projects. I.e. the SESA is carried out with the objective to get an environmental clearance for wind farm development in that portion of the area, where no environmental impacts are expected or can be successfully mitigated. It may already serve as the final report for environmental clearance of

individual future projects or may, at least, minimize the efforts for further project-specific ESIA studies and environmental clearance of individual projects.

The assessment of environmental and social impacts is targeting to

- determine any likely significant impact caused by wind power development in the area;
- assess, whether such impacts can be mitigated or whether they require a restriction or a ban on certain areas with regards to wind power development;
- define eventually necessary mitigation measures and environmental and social management (ESM) requirements; and
- assess the effects of possibly required mitigation and EM measures with regard to the overall viability of wind power development in the area.

1.2 The Project Area

The project area is located in the most north-eastern part of the Eastern Desert which extends between the Nile Valley and the Red Sea. The Eastern Desert is traversed by numerous canyon-like depressions (wadis) running to the Red Sea or to the Nile Valley. The wadis crossing the project are dewatering directly to the East, to the Red Sea.

The project area is located on the western bank of the Gulf of Suez, about 150 km north of Hurghada (see Map 1.1). Minimum distance to the next settlement, Ras Ghareb, is less than 10 km (see Map 1.2). The Red Sea Mountains run from northwest to southeast at a distance of at least 10 km to the western boundary of the project area. The Red Sea stretches from north-west to south-east at distances of 3.0 to 5.0 km to the eastern boundary of the project area. Hence, Suez-Hurghada road that follows the coastline of the Red Sea runs about 2 to 4 km east of the project area. The Ras Ghareb–El Shaikh Fadel road and Wadi Abu Hab run at minimum distances of about 5 km to the southern border of the project area (see Map 1.2).

The project area consists of two sections (see Map 1.2): The larger section has a length of about 43.0 km from north-west to south-east. The width (from west to east) varies between 10.0 and 1.5 km. Furthermore an isolated section, with a length of about 7.5 km from north to south and ca. 2.5 km from west to east, exists west of the southern part of the above-named larger section (coordinates are given in Figure 1.3).

The desert area north-west of Ras Ghareb has an undulating topography. The southern part is rather flat, but the terrain steadily rises from only 35 m a.s.l. to about 200 m a.s.l. when going further west (see Figure 1.1, top). The lengthwise cross section shows that differences in elevation are rather limited in two third of the area, the south-eastern part (ranging from about 80 m to 110 m a.s.l.). In the north-western part of the area the terrain rises up to more than 200 m a.s.l. and becomes more complex and hilly.

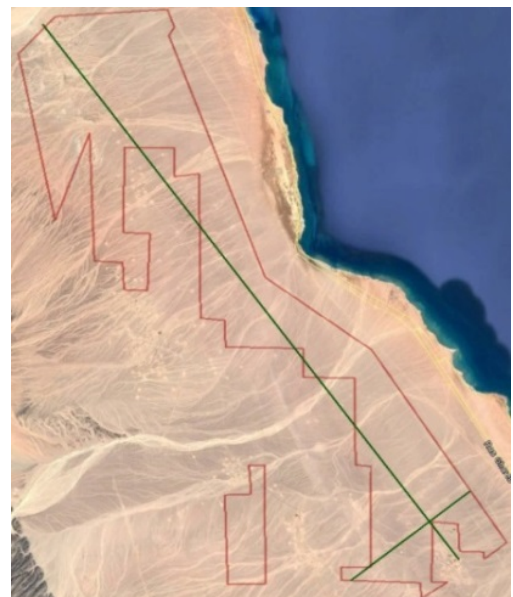



Figure 1.1: Topographical profiles of the project area (top: cross section through the southern part of the project area from south-west (left) to north-east (right); bottom: lengthwise cross section through the project area from north-west (left) to south-east (right) (route of sections can be taken from the Google Earth-image at the top))



Figure 1.2: Impressions from the project area

The project area consists mainly of gravel and pebbly plains (Figure 1.2) and is almost without vegetation. Smaller wadis with sparse vegetation cross the project area on their way from the Red Sea Mountains (in the west) to the Red Sea (in the east). The sparse vegetation consists of

herbaceous plants and single small bushes. Patches with rocky substrate, which rises above the ground surface, can be found rarely.

The area can be accessed via asphalt roads owned by the General Petroleum Company (GPC) of about 7 m width starting from the Suez-Hurghada road in the north of Ras Ghareb. More details on the location and the area as well as on the access road options can be seen from Map 1.3.

No.	Point	Coordinates, UTM Zone 36 R		No.	Point	Coordinates, UTM Zone 36 R	
		Easting, m E	Northing, m N			Easting, m E	Northing, m N
1	B1	470570.77	3176148.23	25	B25	481954.00	3156315.31
2	B2	477968.15	3176711.97	26	B26	480498.75	3156334.58
3	B3	478807.22	3174960.75	27	B27	480465.05	3165577.44
4	B4	478503.61	3174686.11	28	B28	478820.07	3165564.58
5	B5	484594.86	3159004.38	29	B29	478813.65	3165583.86
6	B6	491293.31	3154397.30	30	B30	478807.25	3167392.68
7	B7	499707.32	3142340.15	31	B31	475549.59	3167392.62
8	B8	498348.35	3141540.20	32	B32	475556.03	3161863.60
9	B9	496806.21	3141530.54	33	B33	477168.75	3161857.25
10	B10	496632.76	3143342.54	34	B34	476898.98	3158201.20
11	B11	495187.14	3143361.76	35	B35	475549.60	3158175.46
12	B12	495109.95	3139776.45	36	B36	475523.91	3160064.51
13	B13	495967.65	3139660.81	37	B37	473768.20	3160051.25
14	B14	494232.96	3138485.03	38	B38	473406.80	3168089.38
15	B15	494136.58	3139728.26	39	B39	471079.19	3161800.68
16	B16	489336.81	3139709.02	40	B40	468787.08	3173470.46
17	B17	489346.42	3140586.07	41	B41	470710.33	3175715.13
18	B18	491322.19	3140605.28	42	B42	482171.27	3145260.11
19	B19	491360.74	3146956.83	43	B43	483700.06	3145162.62
20	B20	490223.50	3147082.13	44	B44	483797.63	3147179.29
21	B21	490223.48	3152585.39	45	B45	484741.01	3147114.21
22	B22	486994.74	3152701.07	46	B46	484643.43	3139697.80
23	B23	486908.05	3154474.70	47	B47	482203.86	3139795.39
24	B24	482117.86	3154503.40				



Figure 1.3: Boundary Coordinates (unofficial coordinates taken from GIS) of the 284 km² project area (above) and location of boundary points (below)

Map 1.1
Location of the project area

project area
 project area

● editor: Lars Gaedicke, July 31st 2017

0 150 km

 1:3.000.000



Content may not reflect National Geographic's current map policy. Sources: National Geographic, Esri, DeLorme, HERE, UNEP-WCMC, USGS, NASA, ESA, METI, NRCAN, GEBCO, NOAA, increment P Corp.

Map 1.2
Boundaries of the project area

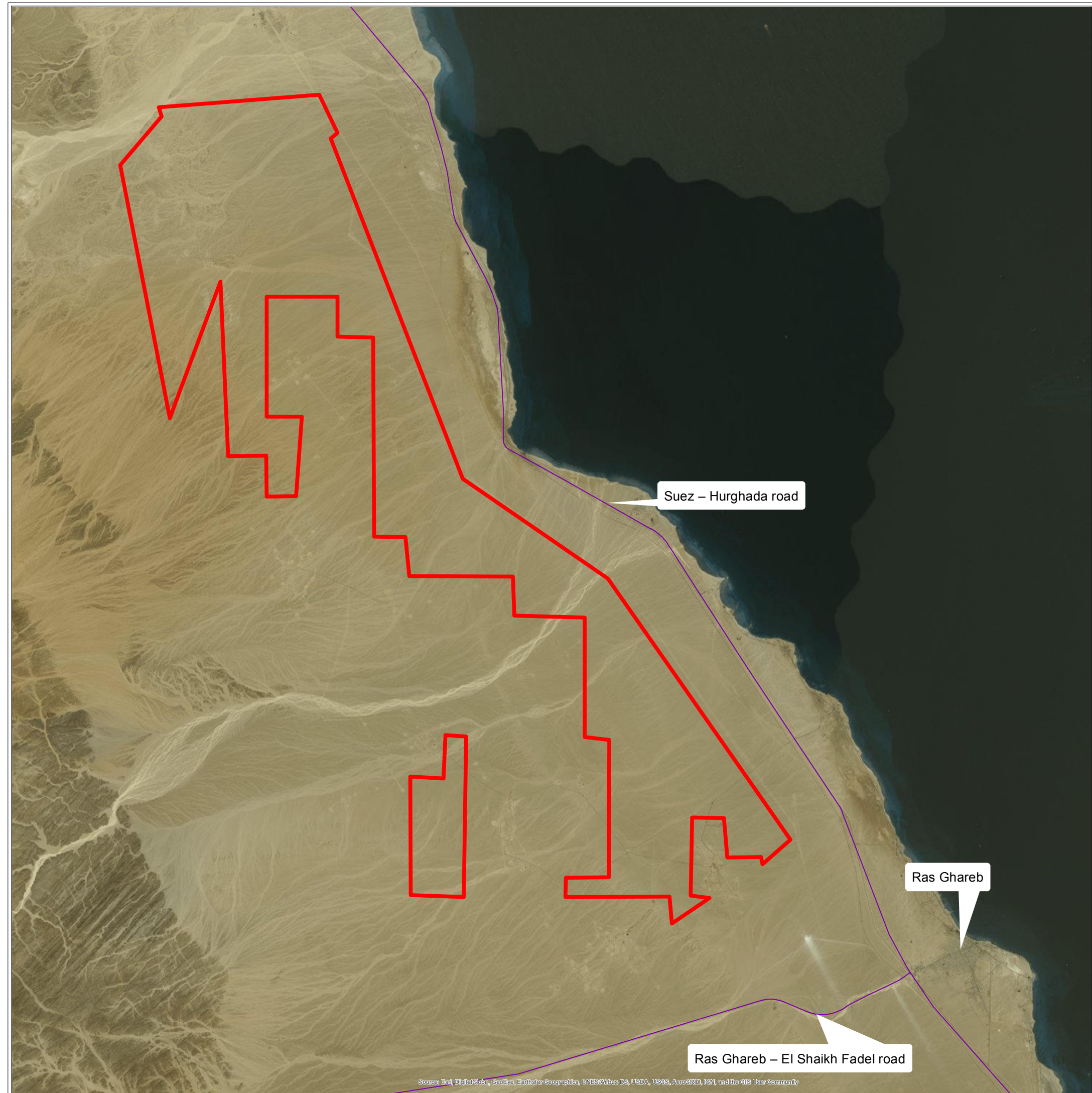
project area
[red outline] boundaries of the project area



● editor: Lars Gaedicke, July 31st 2017







Source: Esri, DigitalGlobe, GeoEye, Earthstar Geographics, CNES/Airbus DS, USDA, USGS, AeroGRID, IGN, and the GIS User Community

Map 1.3
Existing and proposed infrastructure associated with wind farm development

Project Area

 boundaries of the project area

Existing and proposed infrastructure

-  220 kV substation (SS-1; SS-2; SS-3; SS-4; SS-5)
-  existing roads
-  proposed / new roads
-  existing overhead powerline (OHL)
-  proposed / new cables

● editor: Lars Gaedicke, July 31st 2017

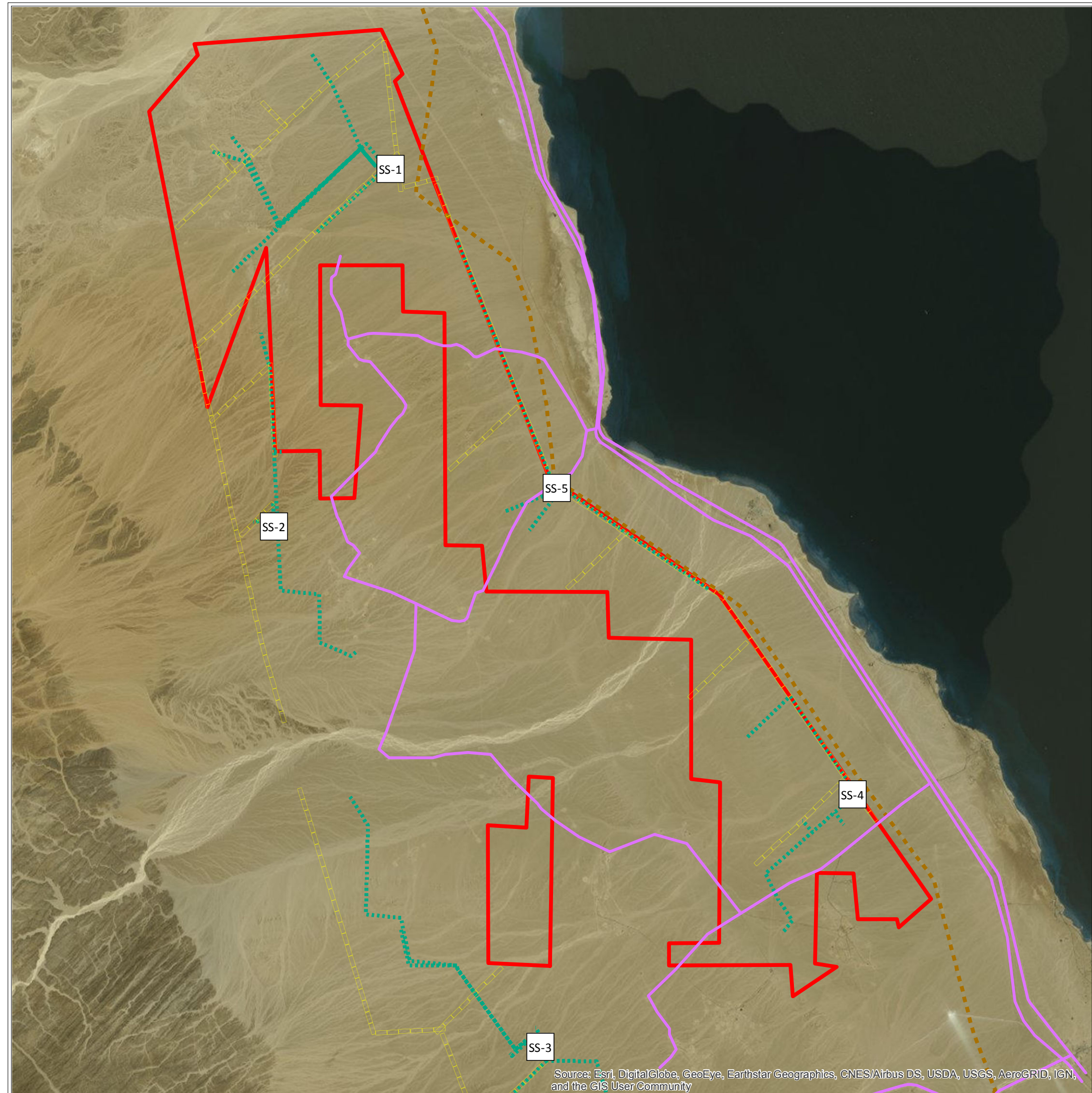
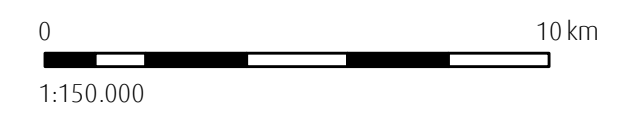

Source: Esri, DigitalGlobe, GeoEye, Earthstar Geographics, CNES/Airbus DS, USDA, USGS, AeroGRID, IGN, and the GIS User Community

1.3 Description of a Typical Wind Power Project in the Area

1.3.1 Technical Description

Although the final split up of the total area into wind farms and the final design of the individual wind farms will be known on a later stage only, once the wind turbine will be selected or determined through competitive bidding, the general project layout of wind farms can already be outlined. This is because wind farm design follows basic planning rules. Moreover, because of the limitation of the maximum tip height (120 m, due to military restrictions) of the wind turbines the spectrum of wind turbines that can be used is also restricted. Accordingly, wind turbines with unit capacity of about 2.0 MW to 4.0 MW, rotor diameters of 70 to 110 m and max tip heights of 120 m are likely to be selected. Regardless of the type selected the WTG shall consist of tubular towers of heights of about 60 to 80 m and maximum base diameter of about 4.5 m, the foundation and the nacelle on top of the towers with the rotor. The rotor speed is expected to be variable with 9 to 25 rpm.

Other typical features of such a project are the wind turbine foundations of about 2 to 3 m depth and a surface of up to 17 m x 17 m in case of a large turbine (3.0 to 4.0 MW), erection platforms of 1,000 to 2,000 m² at each wind turbine and the wind farm internal gravel roads of about 5 to 7 m width. The wind farm internal electrical grid consists of cable trenches and small electrical kiosks next to each wind turbine comprising of ring main unit and possibly as well transformer and/or controller stations, if the latter will not be integrated into the turbines.

Any wind farm in the project area would typically be developed in rows perpendicular to the main wind direction with a distance between each row of around 700 to 1,100 m or even more, distances between turbines within a row will be about 200 to 300 m (see Figure 1.4 and Figure 1.5). The size of foundations would be about 10 m x 10 m (small wind turbine) to about 17 m x 17 m with a maximum depth of 3 m below the surface. An example for a standard foundation of a small wind turbine is shown in Figure 1.6. The dimensions of a foundation excavation pit can be seen in Figure 1.7. An example of wind turbine erection is shown in Figure 1.8.

At each wind turbine a kiosk will be constructed (see Figure 1.9). Depending on the type of selected wind turbine such kiosk will contain a ring main unit, a step-up transformer or even the wind turbine controller. In case of a large wind turbine the controller and the transformer might be contained inside the wind turbine towers. The housing of such compact station (kiosk) would be approximately 2.5 x 8.0 m. Power cable trenches will be attached along the rows near to turbines, having a depth of about 1.0 to 1.5 m and a width of not more than 2.5 m. Inside the trenches plastic pipes with diameter of 5 cm for the control cables will be placed on top of or next to the power cables. The power cables will be connected to two central 220/22 kV substations with an area requirement of about 350 m x 150 m. It is assumed that such HV substations might be co-financed by the different investors in the area and will be constructed under the control of EETC and operated by EETC. Within the wind farm earth roads of about 5 m to 7 m width will be constructed, consisting of compacted desert gravel material. The compacted area will be enlarged next to each wind turbine to erection platforms with a size of about 25 m x 30 m to 25 x 40 m for the erection of wind turbines. Due to the nature of the project and the hyper-arid climate, there is no need for surface drainage.

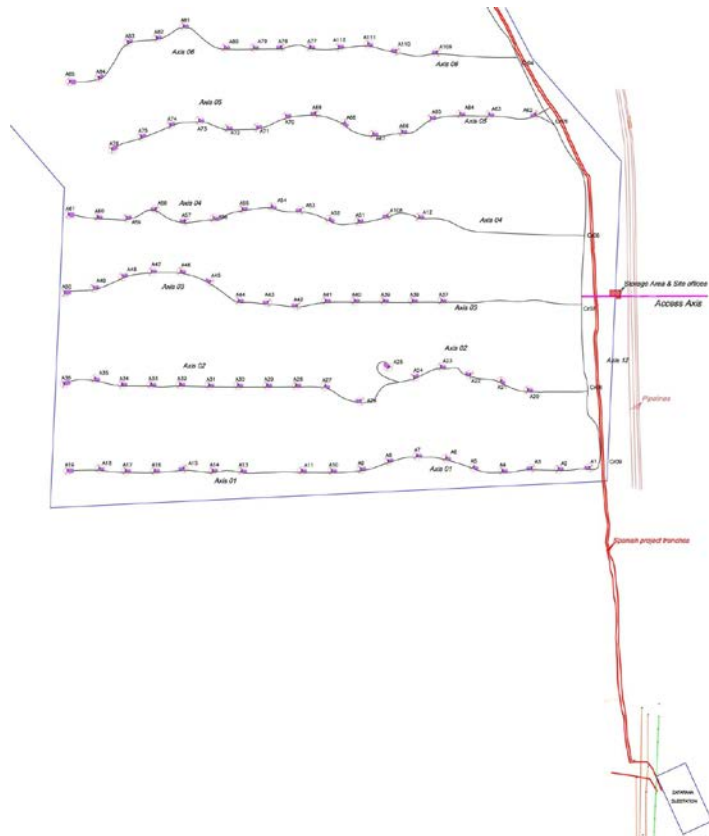

Figure 1.4: Typical arrangement of wind farm siting kiosks and cabling to 220 kV substation

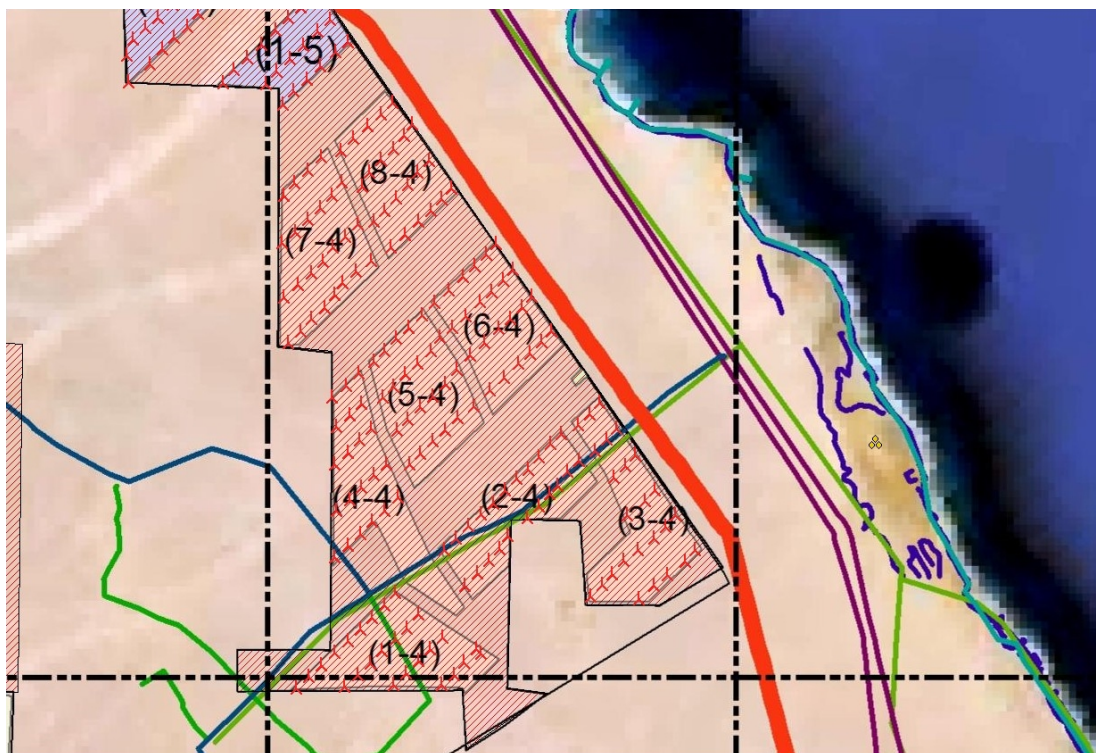

Figure 1.5: Example of a typical arrangement of turbines in rows in the southern part of the 284 km² project area (taking into consideration the provided FiT-plots)

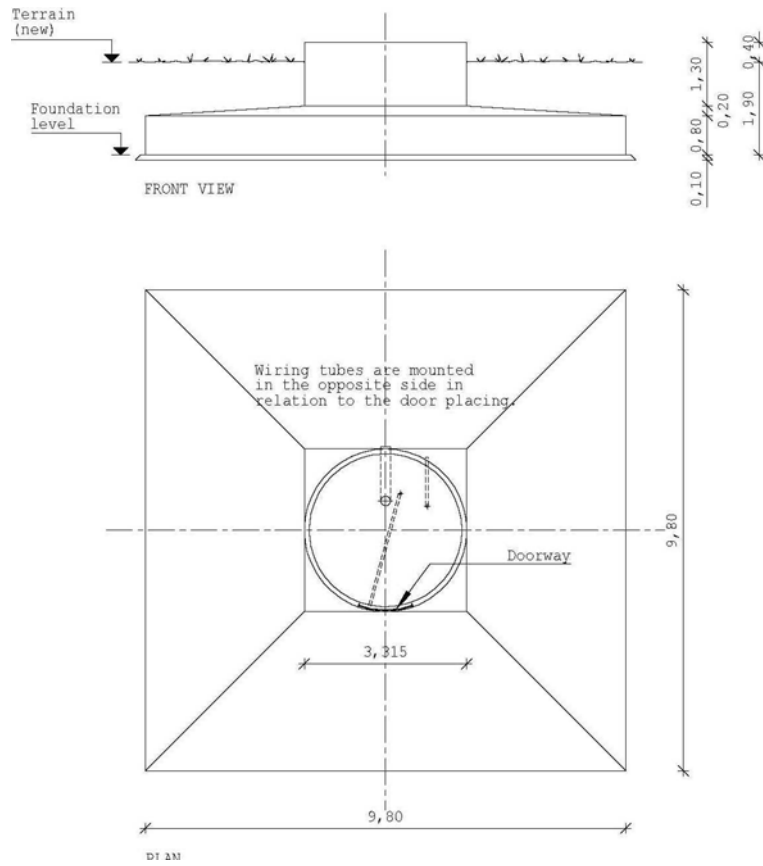

Figure 1.6: Dimension of a typical foundation for a small wind turbine



Figure 1.7: Example of a wind turbine foundation



Figure 1.8: Activities due to wind turbine erection



Figure 1.9: Typical arrangement of kiosks and cabling at each wind turbine

While a wind farm will extend over the whole area only limited land is used for the construction itself. Considering the major items per MW the required land is estimated to be:

Foundation Area	400 m ² /MW
Platforms	1,000 m ² /MW
Roads	2,000 m ² /MW
Cable Trenches	1,500 m ² /MW
Total	3,900 m²/MW

The area affected by construction works is only 0.0039 km² / MW. I.e. approximately 2 % of the overall area is affected by construction work.

In addition, service and control room facilities will be required near to the wind farm areas. Control may take place by remote control routed through a central wind farm server. The central wind farm server may be established in a small container within the wind farm site next to a wind turbine. Service and storage facilities with accommodation facilities of the different investors will most likely be installed or rented outside the project area in reach of water and electricity supply, e.g. in the outskirts of Ras Ghareb.

For wind farms e.g. implemented by NREA itself usually wind farm service installations are constructed consisting of an apartment building, a central facility (conference room, mosque, cantina), a storage premise (e.g. 30 m x 20 m for a 200 MW wind farm), an open storage area and a small control and office building. Water will have to be taken from the Hurghada – Ras Ghareb Nile water pipeline. The number of persons living and working in the area in shifts to operate and maintain the wind farm will probably be not more than 30 for a wind farm of about 200 MW. I.e. the total number of personnel for operation and maintenance of wind farms is estimated to be less than 220. Accordingly, the amount of domestic waste water generated would be less than 7 m³/d (considering an average per capita consumption of 30 l/d). Waste water shall undergo a two stage anaerobic treatment followed by post-treatment of effluents percolated into sandy underground or reuse for irrigation. Sludge would have to be collected every 2 to 4 years (if treatment is properly designed), tried and buried.



Figure 1.10: Suez Gulf (500 MVA) 500 / 220 kV substation

Further installations associated to the wind farm would be two HT/220/22 kV substations and 220 kV overhead powerlines between substations and interconnection to the HT/500/220 kV Suez Gulf substation near Ras Ghareb-El Shaik Fadl road (see Figure 1.10). The routing of the 220 kV line is not yet finally defined, but will have to follow the planning requirements of EETC. As HT/220/22 kV substations and 220 kV overhead powerlines are associated to wind farm development within the project area, they are considered as part of the project within the SESA.

1.3.2 Project Phases

Construction Phase: Site Preparation and Construction Measures

Typical works to be carried out for wind power projects in the wind farm area itself are limited to:

- Earth works: Excavation, backfilling and compaction works for road and platform construction as well as for foundation pits and trenches. Typical equipment used on the construction site are excavators, front-loaders, graders, dozers, dumpers and compactors.
- Concrete works for foundations. As no water will be available at the site it is expected that either ready mix concrete will be used or the concrete will be prepared at a central batching plant within the wind farm and all aggregates, including water, will be transported to that site.
- Wind turbine installation works using large mobile lifting capacities.
- Small foundation works for secondary installations including installation of kiosks.
- Construction activities for HT/220/22 kV substations and 220 kV overhead powerlines have to be carried out under control of the EETC: The works comprise steel structural works, civil works for fencing walls, housing, foundations and trenches and electrical works at medium and high voltage level.
- Construction measures for service and control facilities of the investors (probably outside the wind farm area) would be limited to typical house and storage building works.

The erection works of the wind turbines are usually carried out by the wind turbine supplier with a team of own technicians or by a subcontractor under supervision of the manufacturer. Civil works and electrical works on the MT and HT lines will probably be carried out by local companies.

For wind farm construction a temporary construction yard (for storage of materials and servicing of machinery) and a temporary office would be erected at a central place within each wind farm site. Such temporary facilities comprise of 4 to 6 rooms with simple sanitary facilities. Water supply would be via tankers. Electricity would be generated by a small mobile generator. Such office building would be for about 20 persons, who, however, spend much time at the construction sites. Proper non-hazardous solid waste management during the construction phase will be the responsibility of the Contractor, who shall minimise origin of waste and collect the waste from the site and dispose it of in a regular way. Minor quantities of hazardous waste such as used oil and grease shall be collected and recycled, as it is usually done because of its value.

Construction measures of the investors would be supervised by the owner's engineers. Usually international Consultants would be employed for assistance. Such supervision includes the assurance of Contractor's proper environmental performance, such as waste management and the proper land reclamation at the end of the construction measures. The works and the site personnel have to be supervised by a health and safety engineer, who shall be assigned by the Contractor.

Associated works outside the project area would be

- Construction measures for service and control facilities of the investors outside the wind farm area, e.g. near to Ras Ghareb, would be limited to typical house and storage building works.

- Erection of transmission line towers and pulling of wires for the 220 kV OHL and interconnection line to the Suez Gulf (500 MVA) 500 / 220 kV substation to be carried out under control of the EETC: Structural steel constructions with small foundations including working activities at heights. The routing of the 220 kV will have to be determined during further planning process once configuration of wind farms and the type of wind turbines will have been selected.

The implementation of individual wind farm projects will follow typical sequences and schedules. An exemplary project implementation schedule for a project in the order of about 200 MW is given in Figure 1.13. The construction period is almost 2 years. The start of the first project in the project area would likely not be before end of 2018.



Figure 1.11: Typical temporary office facility at a wind farm site used during the construction phase



Figure 1.12: Example for service building construction for two wind farms of about 200 MW each

Operation and Maintenance (O & M) Phase

Wind farm operation needs intense maintenance. Typical O & M services to be carried out during the operation of the wind farms over their lifetime are

- Scheduled maintenance usually every 6 months according to the maintenance plan. Such service comprises a checking of the wind turbine, change of consumables (e.g. fuses, brake pads, at certain stages also oil change of the gear box, if any) and lubrication as well as minor ad-hoc repairs.
- Trouble shooting, i.e. execution of smaller repairs or replacement of parts to restart the turbine after fault stoppage.
- Major repairs such as replacement of major components like gear box, generator, blade.

While scheduled maintenance and troubleshooting are minor interventions that do not have environmental relevance (only the waste issue of used oil is of significance), the repair or exchange of major parts would be a major intervention requiring the availability of a large crane and of heavy transport means.

Other activities are of administrative nature, such as monitoring and control and accounting.

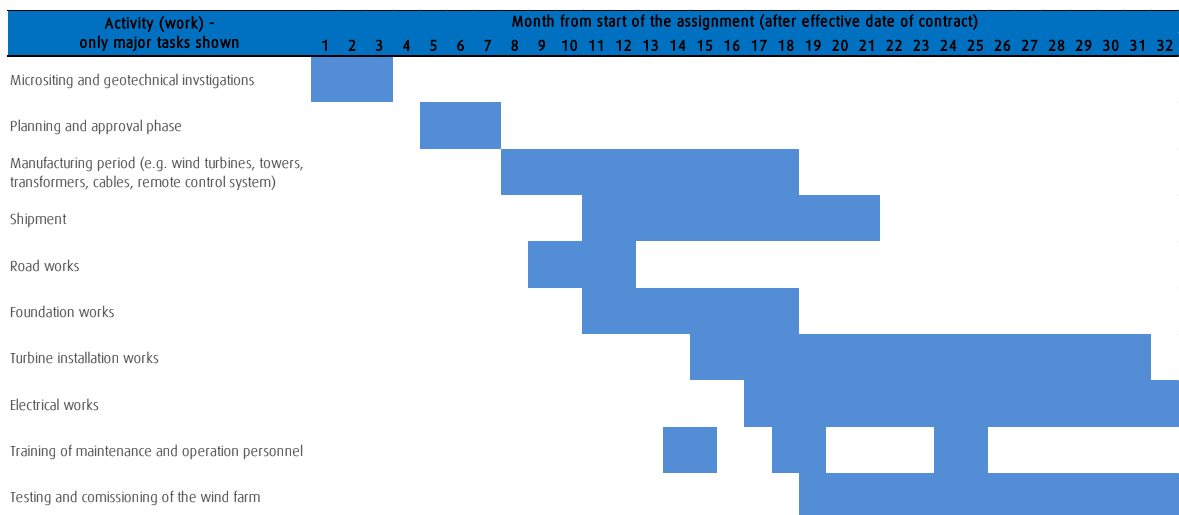

Figure 1.13: Typical Wind Power Project Implementation Schedule

Decommissioning Phase

A typical wind farm is designed for a life time of 20 years. This period might be extended by some time, if the turbines will be well maintained. Decommissioning is part of the project cycle and project cost shall consider the whole wind farm, incl. those parts not any more used for generation, once the decision is taken to stop operation or to repower the wind farm.

The decommissioning shall follow a decommissioning plan. It shall consider all parts of the wind farm being out of further use. WTGs will be dismantled in reverse order of installation. Foundations need to be removed at least up to 1 m below surface, and kiosks shall be dismantled as well as cables shall be removed from the trenches. All materials shall be either recycled (e.g. tower and rebar steel, copper, aluminum) or disposed of according to accepted environmental standards. Excavation pits shall be refilled and the land shall be leveled to harmonize with the surrounding landscape. I.e. the area need to be left in tidy conditions.

2. Public Stakeholders and Public Involvement

Stakeholder engagement and public consultation play an important role in the SESA process and in project-specific ESIA process to meet best international practice.

A public consultation process usually comprises at least two different steps:

- The first step comprises the phase of identifying the scope of the SESA/ESIA. Therefore a Draft Scoping Report is prepared and disclosed to key stakeholders and a Scoping Meeting is held. The Minutes of Meeting (MoM) are prepared subsequently to the Scoping Meeting and are disclosed to key stakeholders.
- The second step includes the preparation of the draft SESA/ESIA Report (incl. Non-Technical Summary (NTS) and Environmental and Social Management Plan (ESMP)), the translation of the NTS in Arabic, the disclosure of the draft SESA/ESIA Report to concerned stakeholders, the execution of a Public Hearing to disclose the results of the SESA/ESIA and to provide the concerned parties with the opportunity to be reassured that points indicated in the scoping meetings have been addressed in the study and to be comfortable with the mitigation measures. Stakeholders are invited and details of the Public Hearing are announced in newspapers and on public notice boards.

A more detailed description on the proposed public consultation process and the identified key stakeholders in the context of the SESA for Wind Power Projects in the Gulf of Suez can be found in the Stakeholder Engagement Plan. The Public Hearing will be organized by NREA accordingly considering all requirements and regulations of EEAA and international lenders.

3. Description of Institutional, Policy and Legislative Environment

3.1 Legislative Framework in Egypt

The environmental protection in Egypt gained a momentum in 1983 by establishing the first protected areas in Egypt and issuing of law 102/1983 for Protected Areas and later on in 1992, when the National Environmental Action Plan (NEAP) was adopted. This created the basis for the national environmental policy and the related regulatory framework. Consequently the legal basis for ESIA was established by Law No. 4 of 1994, the Law on Protection of the Environment and its Executive Regulations 1995 (Prime Ministers Decree 338).

Today the national legal and regulatory framework for ESIA in Egypt is mainly given by:

- Environmental Law 4/1994 amended by Law 9/2009 and its Executive Regulations modified by the Prime Ministerial Decree no 1095/2011;
- Guidelines of Principles and Procedures for Environmental Impact Assessment (“EIA Guidelines”) – 2nd edition (2009); and
- Environmental Impact Assessment Guidelines and Monitoring Protocols for Wind Energy Development Projects along the Rift Valley/Red Sea Flyway with a particular reference to wind energy in support of the conservation of Migratory Soaring Birds (MSB) (EEAA 2013).

Further to the Law on Protection of the Environment and its Executive Regulations, the following legal and regulatory framework needs to be considered in case of wind energy projects:

- Law No. 93/1966 on Wastewater and Drainage and Decree No. 44/2000;
- Law No. 53/1966 on Agriculture;
- Law No. 38/1967 on Public Cleanliness; and
- Law No. 12/2003 on Labour.

Furthermore, legal requirements for wind farm construction are defined in Law No. 101/1996 Building Construction and Decree No. 326/1997. There are no national laws and regulations on shadowing / flickering from wind turbines. Moreover, there are no local standards on the calculation of noise propagation.

As a signatory state the Government of Egypt has to meet environment protection obligations with regard to the

- Convention on Biological Diversity (1994);
- Convention on the Conservation of Migratory Species of Wild Animals (the Bonn Convention, 1979); and the
- Agreement on the Conservation of African-Eurasian Migratory Waterbirds (AEWA).

Accordingly, the criteria and conditions defined in these conventions have to be considered in ESIA.

There are no national laws and regulations on shadowing / flickering from wind turbines. According to European stipulations (e.g. German emission control law) the limit for affecting residencies by shadowing from wind turbine blades is 30 hours per year and/or 30 minutes per day. Moreover, there are neither local nor international standards on the calculation of noise propagation; instead ISO 9613-2 and IEC 61400-11 ed.3 standards were applied.

3.2 Applicable International Environmental and Social Standards

Since development of large wind farms are usually financed by one or more investment banks, the SESA has to follow the standards of international finance organisations. The relevant international requirements are mainly framed by the following:

- Equator Principles;
- EBRD's Environmental and Social Policy (2014); and
- International Finance Corporation's Policy on Environmental and Social Sustainability (2012) and relevant Performance Standards and EHS Guidelines.

The purposes of these standards are to

- ensure that all plans, developments and projects which are subject to investment undergo an appropriate assessment;
- ensure that there are no impacts associated with the proposed plan, development or project investment which are contrary to the bank's environmental and / or social policies; and
- prevent reputational or financial damage to the investor.

The Equator Principles (EPs) form benchmarks for the financial industry to manage social and environmental issues associated with projects that are sponsored or financed by institutions signed up to the principles. The EPs have been designed to ensure that adverse social and environmental impacts resulting from development are appropriately identified and managed throughout construction and operation. Equator Principle Financial Institutions (EPFIs) are institutions who have publicly adopted the Equator Principles and who commit to only provide loans to projects that conform to the EPs. In summary, the Equator Principles require:

- EP 1: A scoping assessment to categorize the project in terms of the magnitude of its potential impacts and risks.
- EP 2 & 3: A social and environmental assessment based on the impacts and risks identified in the scoping assessment, taking into account predefined social and environmental standards.
- EP 4: Preparation of an action plan to effectively manage the impacts and risks.
- EP 5 & 6: Undertake appropriate consultation and discourse with affected communities and set up a grievance mechanism to facilitate resolution of concerns and grievances raised.
- EP 7: Undertake an independent review of the process.
- EP 8: Establishment of covenants in financing documentation to ensure compliance with applicable laws and other requirements.
- EP 9: Establishment of a programme of independent monitoring and reporting to ensure appropriate social and environmental performance is maintained.
- EP 10: Annual reporting by the EPFI on experiences concerning the implementation of the Equator Principles.

The first EP, Principle 1, involves the review and categorization of the project (see Chapter 3.3). The categorization is conducted to determine the potential nature and scale of impacts and the requirement, if any, for further in-depth assessment in EP, Principle 2. Subsequent in-depth assessment under Principle 2 usually takes the form of an Environmental and Social Impact Assessment (ESIA).

3.3 Project Categorization

According to the national EIA Guidelines of 2009, generation of electricity using wind or solar energy (including power lines) is classified as a Category C project (no. 54 in annex 6 of EIA Guidelines 2009). Category C projects are expected to have highly adverse impacts requiring a full EIA study. Moreover, the EIA Guidelines state that projects which have been included in a development, for which an Integrated (Strategic) EIA has already been prepared, shall abide the requirements of the category that is less strict than its original category if the projects are similar. Hence, planning activities prearranging the development of large wind farms in the project area have to be assessed as a Category C.

The involvement of the public and concerned parties is mandatory for Category C projects through the public consultation process. “The consultation process provides the concerned parties with the opportunity to indicate their opinion in the measures to minimize potential negative environmental and social impacts, strengthen social acceptance of the project, informing the concerned parties that the environmental impacts will be minimized to levels that are low as reasonably practical and achieve the balance between legitimate requirements for development and environmental protection” (EIA GUIDELINES 2009, p. 31).

According to EBRD`s Environmental and Social Policy (2014) electric power generations, transmission and distribution (Code 35.1) are assessed as Category 1 projects. Those projects likely could result in potentially significant adverse future environmental and/or social impacts which, at the time of categorization, cannot readily be identified or assessed, and which, therefore, require a formalized and participatory environmental and social impact assessment process.

A full SESA for the 284 km² area has to meet best international practice and specifically the requirements for stakeholder engagement and public consultations.

3.4 ESIA and Permitting Process

According to the national regulations, the competent administrative authority in charge of issuing licences in case of wind energy projects is the Ministry of Electricity. As given in Article 20 of the Law on Protection of the Environment “The competent administrative authority or the licensing body shall forward the abovementioned Environmental Impact Assessment studies to the Egyptian Environmental Affairs Agency EEAA for consideration. The EEAA may give the body preparing the study suggestions concerning preparations and systems necessary to treat the negative environmental effects and demand implementation thereof. The EEAA may also ask the body to provide all the data, designs or clarifications necessary for consideration of the study. The Egyptian Environmental Affairs Agency EEAA shall have to inform the competent administrative authority or the licensing authority with its consideration within a maximum of 30 days from the date of the receipt or completion of the study or execution of the proposals; otherwise, failing to reply shall mean that study is accepted by the Egyptian Environmental Affairs Agency EEAA. The project shall have to start operation within the period granted by the license; otherwise, the environmental approval shall be considered null and void.”

In addition to the Environmental Permit to be obtained through EEAA, further permits are required for the erection and operation of wind farms:

- Construction and operation permit for private investors obtained through the Regulatory Board for the Electric Utility and Consumer Protection Agency established per Presidential Decree No. 326/1997 for construction, operation and electricity generation; and
- Construction Permit acquired through the Red Sea Governorate according to Law 101/1996 to obtain authorisation to construct wind farm buildings,

3.5 Consideration of Alternatives and Justification of the Project

Egypt is characterized by fast growing energy demand. In order to meet the estimated demand an increase of about 37% of primary energy needs to be met by 2022. As a general strategy to meet this demand, the Government of Egypt is focusing as much as possible on locally available natural resources including expanding utilization of renewable energy sources, expansion of electricity and gas integration with neighbouring countries. Therefore, the Egyptian Government has adopted a renewable energy strategy with the target to cover 20% of its electric power demand from renewable energy by 2022. Considering that the hydropower potential has almost been fully exploited, the utilization of wind energy is the best renewable energy choice in case of Egypt. Hence, wind energy is targeting to contribute 60% of the renewable energy share.

The use of renewable energies is considered to be an environmentally compatible form of electricity supply. It saves CO₂ emissions and contributes to resource conservation such as the indigenous oil and gas reserves.

The project area has been allocated to NREA by the presidential decree No. 116/2016 and after that recognized by the National Centre for Land-Use Planning. Comments of competent authorities such as air force and aviation authority have been already received by NREA. Thus, it can be stated that there has already been an internal consultation between competent authorities prior to the selection of the project area. The driving criteria for selecting the area were:

- the area is mostly free from competing uses;
- the area is presumed to be one of the areas in Egypt with the highest wind power potential;
- the area mostly consists of vast desert grounds with only sparse vegetation being considered to be of limited ecological relevance;
- the geomorphology of the area is favourable for wind power development requiring limited construction and landscape modification measures; and
- the access to the area can be considered to be easy requiring only limited road construction measures.

Wind farm development in the area is needed, because it will

- provide a valuable source of renewable energy for use within Egypt to support infrastructure developments;
- strengthen Egypt's energy sector by helping to diversify its energy sources;
- reduce the country's reliance on fossil fuel;
- help Egypt achieving its targets in terms of development of renewable energy;
- mark Egypt as a developing state with a commitment to reduce its Greenhouse Gas emissions; and
- provide local jobs and improvements, specifically during the construction phase.

Hence, no equivalent alternative for wind power development can be currently made available.

The so-called "zero-alternative", i.e. the no-action alternative, would result in an increased deficit between electricity demand and actual power generation. Even at present, power supply problems still occurred in Egypt. Without additional wind power projects in selected areas the additional electricity demand would have to be satisfied by conventional power stations, which due to lack of natural gas would have to be operated with heavy fuel oil. Thus, CO₂ free renewable electricity generation would have to be mainly compensated by heavy fuel oil fired power plant generation with significant CO₂ emissions, counteracting to emission control goals. In addition, heavy fuel oil would have to be imported at high economic cost.

Furthermore, the expected high capacity factor of the wind power potential, especially during summer, would deliver some firm generation capacity, which can be considered to substitute investments into conventional power generation capacity to meet future demands. Thus, the zero-alternative would imply adverse effects on CO₂ emissions, on the economy and would counteract the political aims mentioned above.

A further analysis of alternatives shall be conducted in future project-specific Environmental and Social Impact Assessments (ESIAs).

3.6 Main Approach

The main aim of the SESA is to facilitate wind farm development in the project area with the least possible environmental and social impacts. Therefore the main approach of the SESA follows general national guidelines for EIAs (EEAA 1994), special national guidelines for wind farm projects (EEAA 2009, 2013), international requirements (e.g. Equator Principles) and, finally, general rules according to the state-of-the-art for execution of SESA/ESIA processes. The approach comprises a scoping (incl. a comprehensive review of available data on the physical, biological and social environment of the project area, a data gap analysis in order to identify what baseline data is additionally needed and a determination of an appropriate level and extent for additional data collection), baseline studies, impact prediction and evaluation and mitigation (see Figure 3.1).

An extensive desk study assessment revealed baseline information on the physical, biological and social environment of the project area, especially on

- nationally or internationally designated nature conservation areas that might be in conflict with the project purpose;
- protected, threatened or rare species of flora and fauna expected to be present in the area,
- topography and geomorphology of the greater area, climate, geology, seismology and hydrology.

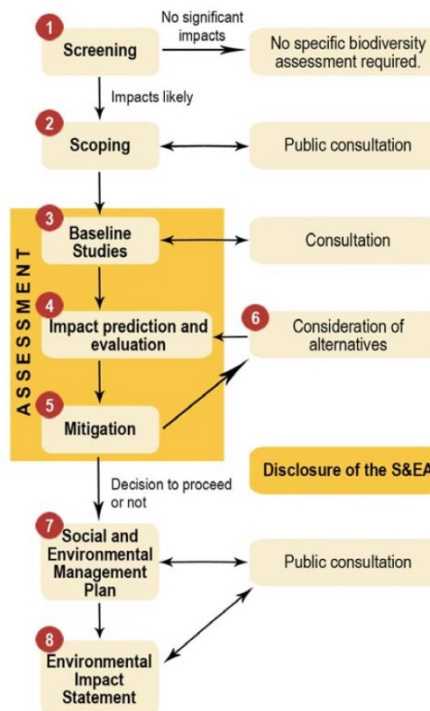

Figure 3.1: Typical approach of SESA/ESIA process

Previous environmental and social impact assessments of wind power projects at the Gulf of Suez give valuable baseline information and form the starting point for the SESA for the project area (e.g. Strategic ESIA for the 300 km² area conducted by JV LI & ecoda 2013). A number of bird monitoring studies have shown that migration of soaring birds during spring and autumn is the most crucial environmental issue for wind power development in the region. Hence, a focus of the SESA is therefore on migrating soaring birds and the mitigation of possible impacts on birds. On that background an ornithological investigation was carried out in spring 2016, autumn 2016 and spring 2017 (see Chapter 4.3.4).

To gather additional and more detailed data, especially on geomorphology, landscape characteristics and (competing) land use, plants, animals and other specific features that might exist in the project area, additional site visits have been conducted during the ornithological investigation by Dr. Zegula, Dr Bergen and LI expert. Additional site visits have been undertaken by Dr. Mostafa Saleh. During these site visits a combined transect- and point-count method was used with mainly direct observations. For that purpose, the expert slowly drove with a 4x4 Land Cruiser through the whole project area in search of existing plants, present animals or other specific features. At certain locations the surrounding was “scanned” with binoculars for plants and animals and studied in order to find burrows or scats, which might indicate the presence of animal species. Places where plants had been found were prospected in detail. For species identification of existing plants photos were taken, identification guides and internet sites were used. Important spots with characteristic species or other important habitat features were registered by GPS.

4. The Existing Environment

4.1 Wind Energy Potential

The presentation of the wind energy potential is prepared for the Gulf of Suez 284 km² project area in order to show the expected wind energy speed in the area. This presentation is not a wind energy yield assessment. There is no wind farm layout considered in the wind energy potential. According to the provided information from RCREEE, the project area is consisting of 30 FIT plots, part of which are already been given to some of the developers and the other parts are still under negotiations. Each of the provided land plots will comprise of total installed capacity of 50 MW and each of the developer will choose the type of the turbine at a later stage of the project development.

The wind raw data provided by RCREEE are as follows:

Met mast name	Raw wind data from	Raw wind data to
Masdar 1	01.01.2016	27.06.2016
Masdar 2	01.01.2016	27.06.2016
Masdar 3	01.01.2016	27.06.2016
Ras Ghareb	01.01.2016	28.05.2016
St. Paula	09.02.2016	29.06.2016
Ras Ghareb	02.01.2011	31.12.2011

The raw wind data used in the presentation of the wind energy potential are for met mast Ras Ghareb from 02.01.2011 until 31.12.2011. The met mast is located approx. 8 km to the closest south border of the project area and approx. 52 km to the farthest north border of the project area. The Ras Ghareb measurement mast is with a total height of 24.5 m. Figure 4.1 shows the summary of the wind data as well as wind rose and histogram of the wind data.

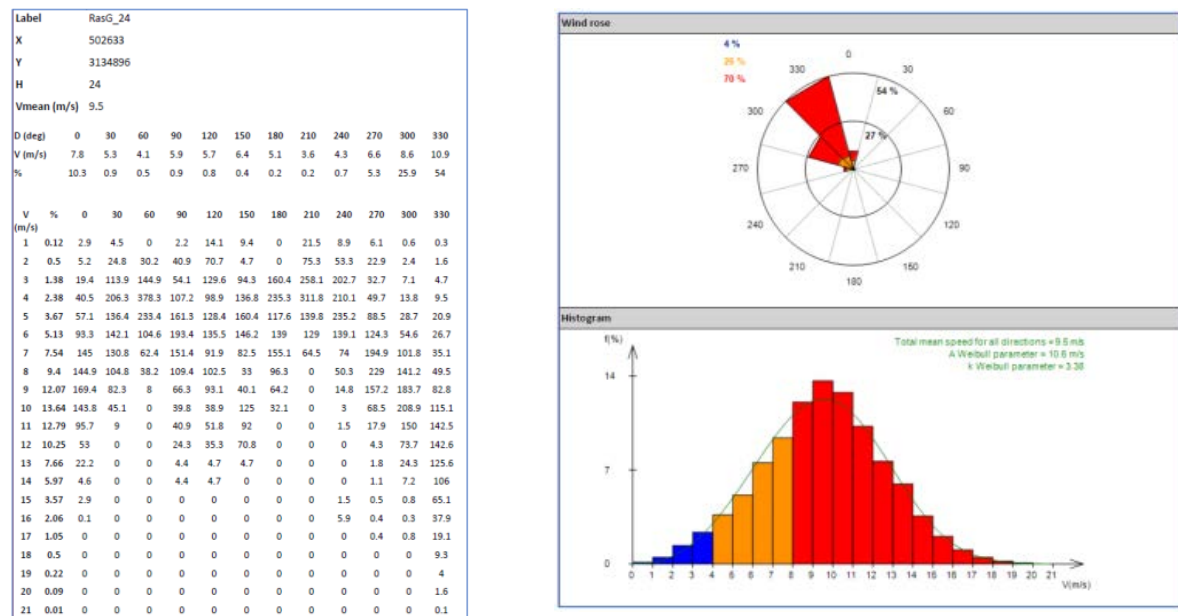

Figure 4.1: Ras Ghareb wind data summary, wind rose and wind speed distribution

The total mean wind speed from the wind mast data is 9.5 m/s for all directions and the Weibull distribution is 3.38.

The available raw wind data were analysed and wind model was created with the software WindPro (version 3.1) and Wasp (version 11.5). The wind data were extrapolated and the wind speed was calculated at 80 m, as the wind turbines with hub height approx. 80 m is most likely to be used in the project area. Figure 4.2 shows the wind energy map in the project area as well as the location of the met masts.

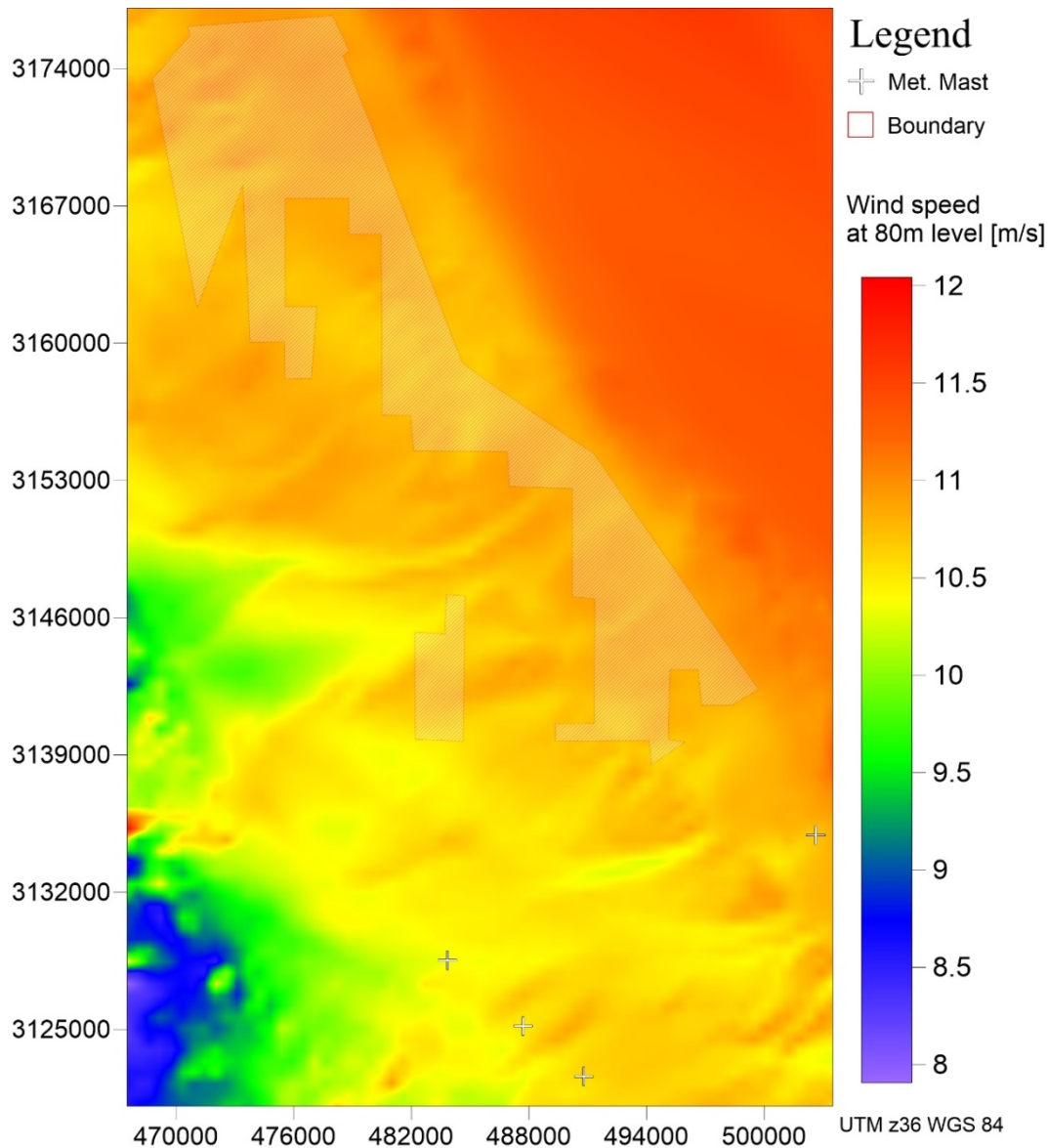

Figure 4.2: Wind map of the project area

As the terrain is flat and the area is desert area, it is classified as non-complex terrain. The wind map shows excellent wind conditions with the range of wind speed from 10.5 m/s to 11 m/s at 80 m height.

As the above wind map is only for presenting the expected wind energy in the project area, cannot be used for any energy yield assessment, it is recommended that every investor follows the IEC standards for project specific wind mast installation and to develop project specific wind energy yield assessment.

4.2 Physical Environment

4.2.1 Climate

The area is located at about 33°E and 28°N between the Red Sea Mountains and the Gulf of Suez within the arid zone of Africa. While the area itself can be classified to be hyper-arid further to the west at the mountains, especially at the Gabal Ghareb in the south, strong rain can rarely be expected, causing runoff through larger wadis towards the Red Sea (see Chapter 4.2.3).

The climate is dominated by a wind circulation system from northern high pressure to southern low pressure systems all over the year, causing wind blowing from northerly directions. Due to the channel effects of the Red Sea and the Sinai mountains the strength of the winds is enforced and the direction is pronounced. Accordingly, in the project area the dominant wind direction is from northwest in parallel to the mountain ranges. Winds are stronger and more stable blowing from northwest during summer, when the pressure gradients are more pronounced. During winter winds may turn to the south during some days. However, southerly wind is blowing at reduced strength.

In Egypt, a number of meteorological stations exist. However, no station is located in the close vicinity of the project area (see Figure 4.3).



Figure 4.3: Meteorological stations located within 200 km from the project area

For describing the general climate of the site, recent 20-year average data from the next meteorological station at HURGHADA INTL, about 150 km to the south of the project area, can be taken (measurements taken near to the project area are available, but cover only a period of one year and are therefore not meaningful) (see Table 4.1).

Table 4.1: Monthly averages values at the HURGHADA INTL meteorological station

	Jan	Feb	Mar	Apr	May	Jun	Jul	Aug	Sep	Oct	Nov	Dec	Year
Average wind speed (m/s)	5.3	5.6	5.9	5.9	6.2	7.1	6.4	6.8	6.8	5.8	5.3	5.4	6.0
Average temperature (°C)	16.3	17.7	20.5	24.1	28.0	30.8	32.2	32.5	30.2	26.6	22.0	18.0	25.0
Maximum temperature (°C)	30.0	33.9	37.2	41.1	45.0	46.1	43.9	46.1	42.2	39.4	36.7	32.8	46.1

The average maximum temperature in the area range from 30 °C (January) to about 46 °C (August) and the average temperature varies between about 16.3 °C in January and 32.5 °C in August.

The average annual precipitation is about 4 mm. Rainfall is very sporadic in this hyper-arid area. It is variable from year to year and characterized by its irregularity both in time and space. Due to the special landscape feature with the 1,750 m high Gabal Ghareb about 30 km south of the project area, average precipitation is presumed to be higher in the mountains. Heavy rains in the mountains can cause flash floods in the wadis such as Wadi al- al-Hawwashiyah in the south of the project area. There is no statistical evidence on the occurrence interval of such rains. From verbal information received it can be guessed that it should be of an order of once in 10 years.

Wind speeds are known to be comparably high according to the measurement data from the station. Based on the data from the measurement and HURGHADA INTL station, it is obvious that winds are blowing from north-western sectors, but not from the sea side. Nevertheless, as the desert grounds have high salt content the climate has to be considered to be aggressive.

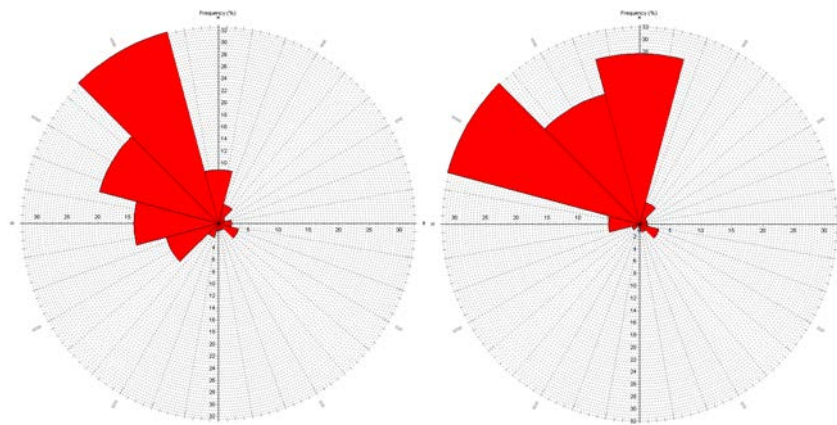

Figure 4.4: Wind rose at measurement mast and HURGHADA INTL station

It is noteworthy that the natural conditions, especially the drastic dry and windy conditions, are very much limiting the biodiversity of the site:

- In exceptionally rainy years, runoff water is being collected in low parts, what may lead to the growth of some plants. However, these plants are subjected to long dry periods.
- The high wind velocity plays an important role in the severe erosion of the soil. The ground surface is mainly covered by compact layer of pebbles and gravels. These represent desert armour, which prevents the permeation of rain water or spilled water to the subsoil. The high

wind velocity removes seeds. So, the chance for seeds to germinate and establish themselves is very poor.



Figure 4.5: Measuring mast south of Ras Ghareb-El Shaikh Fadel road

4.2.2 Air Quality

There are no emissions inside the area that might have an effect on air quality.

Traffic on the Hurghada-Suez road, located about 3 km east of the project area, is not that high and has no significant relevance for air quality.

Deterioration of air quality takes place during windy days: Due to the desert character of the area the level of dust and fine sand content in the air is quite high in case of high wind speeds which reach 15 m/s and more. Based on wind speed measurements at nearby stations such high wind speeds are expected to be in the order of 8 % of the time.

Sulphate containing flare gases from EPC exploration / production wells cause acidic emissions to the surrounding of the southern part of the project area. However, due to the strong wind and the distance of these EPC exploration / production wells there should be no impact on the project area from these sources.

The desert soil contains significant concentration of salt, which is taken by stronger winds. Moreover, about 10 % of the wind is coming from the northern sector and has absorbed salt, when passing the Gulf of Suez. High variation of the daily temperature can cause condensation during early morning times out of the salt containing air. Accordingly the environment has to be classified as aggressive having a high corrosion level.

4.2.3 Water Resources and Waste Water

The project area can be classified to be hyper-arid. There is not any surface water in or nearby the project area (only temporarily after a heavy flash flood, see Figure 4.6). It is crossed by some wadis, like Wadi al-Hawwashiyah in the southern part of the area, that originate in the Red Sea Mountains in the west and run in north-eastern directions to the Red Sea. The wadi cross-sections have a pronounced profile. The dimensions of existing wadis and erosion channels in wadi beds are evidence for discharge that occur from time to time. The discharge may have the form of flash floods that rarely occur. In late October 2016 a thunderstorm and heavy rains caused such a huge flash flood in the region around Ras Ghareb (see Figure 4.6). There is no statistical evidence on the occurrence interval of such rains. From verbal information received it can be guessed that it should be of an order of once in 10 years.

Groundwater in the region can be differentiated into

- fissure water of the weathering zone, which is confined to igneous, metamorphic and sedimentary rocks (only little water that can be stored and collected during rainfall and that can travel over long distances through fissures);
- groundwater at the alluvial fill of the wadis (recharged from occasional rainfalls in the mountains and draining fissure water); and
- deep groundwater that is contained in tectonic fractures and fissures.



Figure 4.6: Results of the heavy flash floods occurred in late October 2016 in the project area

In absence of water wells in the project area there is no information on the groundwater level. However, from a water well field about 30 km in the south-west of the area it can be concluded that the water table is more than 100 m below the surface.

There are no human activities in the project area that use water or cause drainage. The general water supply of the region is from Nile water. A main Nile water pipeline is passing at about 3 km distance from the outer eastern border of the project area in parallel to the Suez - Hurghada road.

4.2.4 Geomorphology and Soil

According to the Geological Map of Egypt the project area is characterized as Undivided Quaternary consisting of wadi and playa deposits or raised beaches and corals of the Red Sea coast (Figure 4.7).

The project area mostly comprises of leveled land. Most of the area is covered with compact angular gravels and pebbles forming a so-called desert armour (see Figure 4.8). The size of the pebbles is around 30 to 50 mm. The level of the whole project area above sea level ranges from 35 m a.s.l. in the south-east to about 250 m a.s.l. in the north-west.

In general the surface and underground conditions are judged to be mostly stable and to have good bearing conditions and to be favorable for tower foundation construction. Thus, the geological conditions will not require major construction measures that might be adverse to the environment.

The area is not affected by fault lines. Studies confirm that the frequency of shallow earthquake occurrences in the Gulf of Suez region was low during the period of 1953 to 1981 (Said 1990). Tectonically, the Gulf of Suez is located in the stable shelf of Egypt.

4.2.5 Landscape Character and Existing Views

The landscape of large parts project area can mainly be described as flat levelled desert plains without any specific features (see Figure 4.8). Hilly terrains can be found in its north-western part. The area is gently sloping from east to west without pronounced landscape features, i.e. there are no steep slopes or escarpments that might be adverse for wind power development. The lowest point of the project area (35 m a.s.l.) can be found in the south-east, while the level of the northern part of the area ranges between 150 and 250 m a.s.l.

The area shows mainly desert gravel plains, i.e. most of the area, is covered with compact angular gravels and pebbles forming a so-called desert armour.

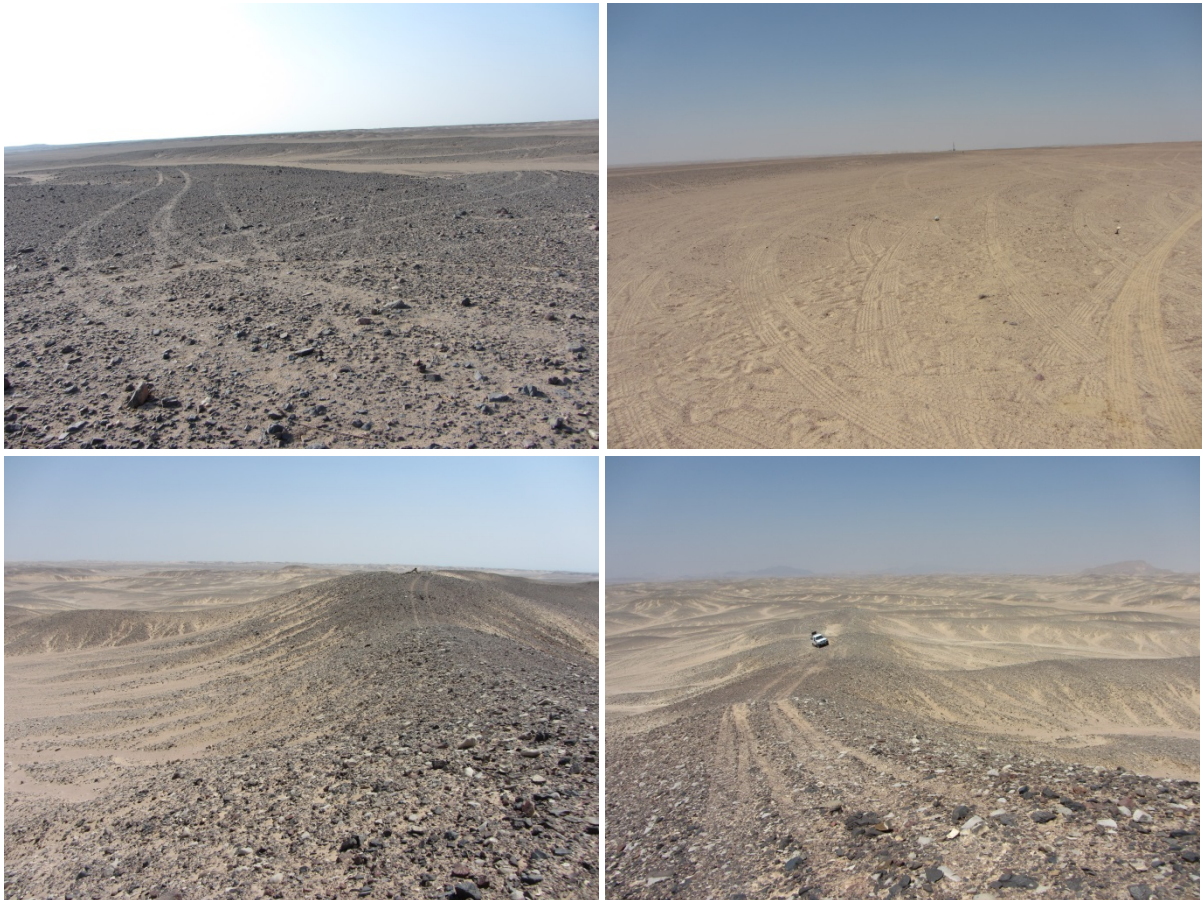

Figure 4.8: Typical surface material in the project area: levelled desert plain in the southern part of the project area (top) and hilly terrain in the north-western part of the project area (bottom)

4.3 Biological Environment

4.3.1 Data Collection

Baseline data on the biological environment was collected by a combination of different approaches:

- A comprehensive review of general information on habitats, flora and fauna likely to be found on the desert plains between the Red Sea Mountains and the Eastern Coast of the Red Sea (e.g. Abd El-Ghani et al. 2013, Baha el Din 2006, Fouad 2016, Harhash et al. 2015, Hoath 2009, Osborn & Helmy 1980, Saleh 1993, 1997, Zahran & Willis 2009, Zahran 2010).
- An analysis of specific data on protected areas, habitats, flora and fauna in the project area and its surrounding. This particularly comprises
 - a. the ESIA/SESA study for the 300 km², which borders west to the project area and which gives profound information on the environment northwest of Ras Ghareb;
 - b. other environmental studies conducted in areas west and southwest of Ras Ghareb (e.g. JV LI & ecoda 2011, Bergen et al. 2016); and
 - c. an extensive research on baseline information in the World Wide Web (e.g. websites of EEAA, BirdLife International, local NGOs).

- An analysis of aerial images to gather baseline data on existing habitats and vegetation

Aerial images give valuable information on vegetation cover of an area even at a high resolution. Information on vegetation cover and on the occurrence and location of relevant spots of vegetation within the project area was gathered by an evaluation of available Google Earth satellite images. Patches of vegetation were identified and their ecological importance was estimated based on size, density of vegetation cover and persistence as inferred by examining older imageries.

The results of this analysis reveal important information and form a starting point for the site visits.

- Site visits to gather baseline data on existing habitats, flora and fauna

Site visits were conducted by local and international environmental experts aiming at gathering information on

- a. vegetation cover, resident and transient land fauna and their ecological relations;
- b. differences in vegetation that can be found in drainage channels (wadis), at lower parts of the coastal plains and at hillier areas in the west/northwest; and
- c. key terrestrial biodiversity present at or near the project area, including endangered and protected species.

According to the extent of the project area, its accessibility and the scope of the SESA the general approach was to sample habitats in the area rather than to undertake a full survey.

Based on the results of the evaluation of aerial images a field survey plan was developed to investigate samples of habitat patches that might be of ecological importance. The plan included field survey routes that comprised the identified patches. Survey routes were imported into a Garmin GPS to guide the field work (Figure 4.9). In the field, each survey route was followed in a four-wheel drive vehicle equipped with a GPS navigation system. The survey route was photographically recorded by a vehicle-mounted camera. Ecological data was gathered visually and recorded on a data sheet. Spots of vegetation were examined by foot for plants and tracks or other indirect evidence of occurrence of animals. Physical and biotic attributes of the sampled

spots and their flora and fauna were recorded and photographically documented. Types of encountered habitats and their associated animal and plant species and their general attributes in the study area were recorded. Location, physiognomy, structure and composition of vegetation cover were recorded whenever any significant natural cover was encountered. Plant species identification followed the taxonomic keys of Boulos (2005). Identification of plant communities followed the description given by Zahran and Willis (2009) and Zahran (2010). Habitat types were identified according to Harhash et al. (2015) and to the system developed by the National Biodiversity Unit (Ayyad & Ghabour 1993, Saleh 1993).

The sampled patches were selected to provide a good representation of habitats, flora and fauna of the project area in the most efficient way. The obtained data provide adequate representation of the habitats of the project area.

- Site visits conducted in the context of the bird monitoring (see Chapter 4.3.5)

Any data on animal species recorded by chance during bird observation, before or after an observation unit or while driving through the project area was collected (species, number of individuals, date, time and location of record) and subsequently entered in a database. Relevant spots of vegetation (habitats) discovered while driving through the project area were mapped and subsequently investigated.

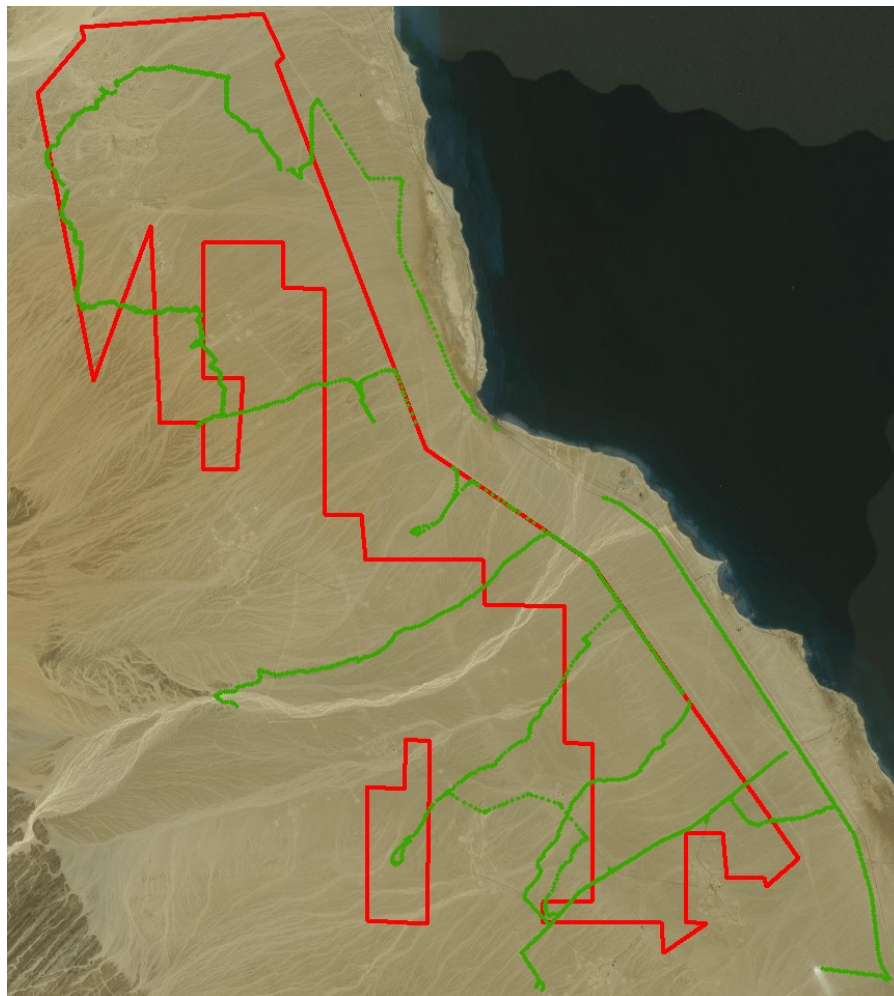

Figure 4.9: Main survey routes used during site visits for baseline surveys on habitats, flora and fauna

4.3.2 Protected Areas

The investigation reveals that there are no national parks or other designated protected sites in the project area (e.g. EEAA 2015, Fouda 2006).

However, in the south-east a small part of the project area overlaps with the so-called “Gebel el Zeit” area (EG031) which was nominated as an Important Bird Area (IBA) by BirdLife International (see Map 4.1; BirdLife International 2017). The IBA site consists of a narrow (about 10 km), 100 km-long strip extending along the Gulf of Suez / Red Sea coast, from north of Ras Ghareb to the bay of Ghubbet El Gemsa in the south. The IBA site was nominated because of its importance as a migration corridor for soaring migrants, particularly birds of prey and storks. Gebel El Zeit itself is an isolated, elongate mountain that reaches up to 457 m and is directly located at the Red Sea. It serves as a stepping-stone for birds crossing between the western coast of the Gulf of Suez and south Sinai in spring (see Baha El Din 1999). The Gebel el Zeit itself is located at a minimum distance of about 65 km south-east of the project area.

4.3.3 Habitats



Harhash et al. (2015) aimed to develop a suitable habitat model for large scale planning to support the decision making process towards natural resources in Egypt. The obtained habitat classification includes a total of 5 main habitat systems, 12 habitat sub-system and 36 habitat classes.

Applying the classification elaborated by Harhash et al. (2015) to the habitats found in the project area during site visits and field surveys the whole project area must be attributed to the main habitat system “Desert” with its four Sub-Systems “High Land”, “Plain Land”, “Low Land” and “Caves”. The vast majority of the project area can be classified as “Hamada Desert” (Sub-System: “Plain Land”) that is crossed by “Valleys and Canyons” (i.e. wadis) which belong to the Sub-System “Low Land”. Finally, special habitats of minor extent, “Caves and Karsts”, are known to occur in the project area, too.

The project area, located on the coastal desert plains northwest of Ras Ghareb, consists mainly of flat pebble desert cut by shallow drainage lines (see Figure 4.10). As typically for desert regions, habitats are limited in diversity and coverage. Plant and animal life is restricted to locations that have certain topographic features, which allow adequate moisture to be available at or near the ground surface. Such locations can be found in lower drainage channel habitats (wadis, see Figure 4.11) which are marked with fine sand and clay sediments deposited by old, slow surface flows. Rain coming from the mountains in the West drains into the wadi systems and tends to form torrential floods. These floods not only carry with them rocks, sometimes very large ones, but anything growing that happens to be in their way. As a consequence, the main wadi channels are usually devoid of plant life. Vegetation becomes established particularly on the wadi banks above flood level (Figure 4.12). However, in lower reaches of wadis, where they spread out and are less steep, floods have lost its power and remaining water can sink into the ground sufficiently to support vegetation for years to come (such areas can be found east of the project area near Suez-Hurghada road, see Figure 4.12). Consequently, the importance of wadis as a habitat for plants and animals differs.

The amount and quality of surface and subsurface water in most wadis crossing the project area seem to be too small to support any, but the most rudimentary plant or animal life. Outside the drainage lines, the project area is almost totally barren of any vegetation and supports very little permanent animal life (Figure 4.14). Hence, the habitable part represents a very small fraction of the whole project area. The distribution of such area is directly linked to topographic and geologic features that control the capture and distribution of the very scanty water resources.

Map 4.1
Northern part of the Important Bird Area (IBA) "Gebel el Zeit" (EG031)

- Project Area**
-  Boundaries of the project area
 -  IBA "Gebel el Zeit" according to BirdLife International (2017)

IBA "Gebel El Zeit"

● editor: Lars Gaedicke, July 31st 2017

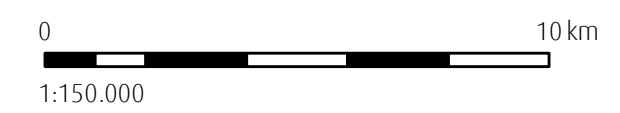



Figure 4.10: Flat and barren pebble desert in the project area (arrows point to shallow drainage lines with finer sediments)

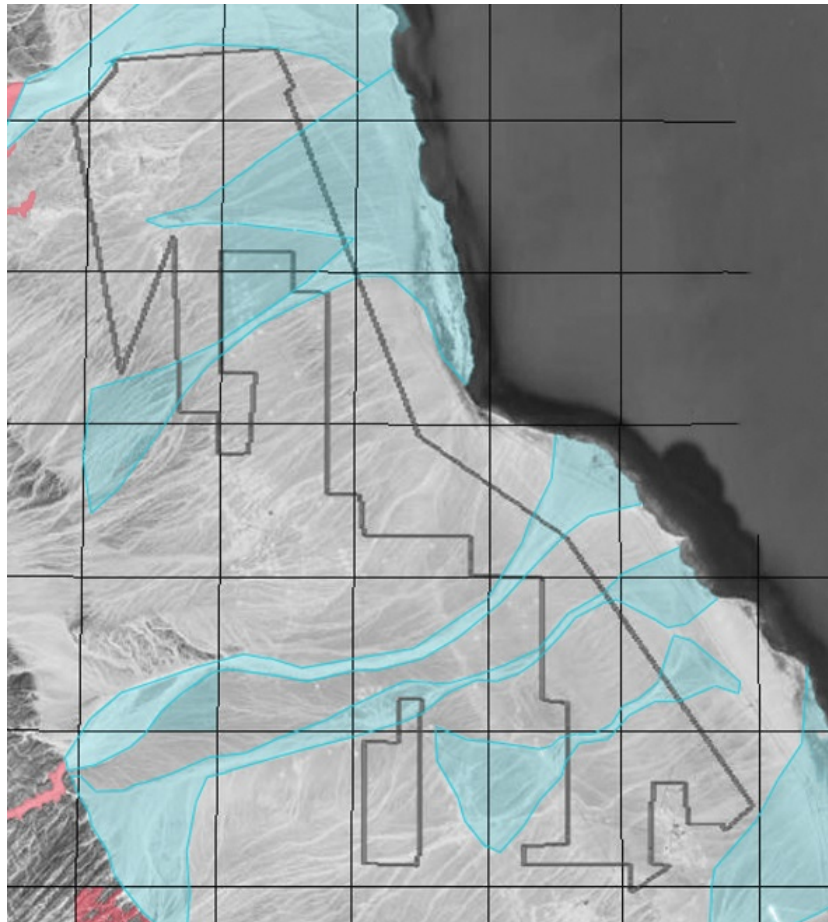

Figure 4.11: Schematic presentation of location of lower drainage channel habitats (blue) and rocky wadi habitats (red; only outside the project area)

Wadi Um Tinassib and Wadi al-Hawwashiyah and their many distributaries cut across the project area. Their lower sections, east of the Suez-Hurghada road, flows outside the project area and seems to feed in extensive, halophyte vegetated coastal Sebkhhas near Ras Abu Bakr. Within the project area these wadis, however, are almost completely barren.

Just north of (outside) the project area Wadi Uldahal, a large wadi, drains a vast watershed from the hilly area (mainly the Eastern Galala Qibliya Plateau) to the Red Sea Coast. South of the project area the main trunk and tributaries of Wadi Abu Hadd discharge into an extensive, coastal salt march west of the Suez-Hurghada road (Figure 4.12). Even this wadi complex is very sparsely vegetated.

Caves, mainly dissolution caves, form particular structures in the desert that offer important habitats for animals (e.g. as shelter). No were found in the middle and southern part of the project area which is rather flat and homogenous. At single locations in its northern part, i.e. at slopes where elevated areas with a rocky subsoil decline into wadis, small caves or crevices occur, e.g. west of observation site 1; see Figure 4.13). These plots are assessed to have an importance as a habitat for animals, e.g. as a shelter against the sun or as a nesting site for local birds.

To conclude, due to the extreme aridity the vast majority of the project area (even most parts of the wadis) is completely without vegetation and do not serve as a suitable habitat for plants. These areas have a very low to no importance as a habitat for plants and a very limited importance as a habitat for animals.



Figure 4.12: Vegetation found in the project area on a wadi bank above flood level (left) and *Tamrix nilotica* in Wadi al-Hawwashiyah near the Suez-Hurghada road (outside the project area)



Figure 4.13: Crevices at a steep slope with rocky subsoil forming potential habitats for animals (e.g. as a nesting site for local birds; right)

4.3.4 Flora and Fauna (except birds)

The region northwest of Ras Ghareb is characterized by the exceeding aridity of the desert climate and a relief basically consisting of gravely and pebbly plains. Accordingly, the potential of this region to serve as a habitat for flora and fauna is extremely low. It can be described as a desert with almost no vegetation, except small spots of isolated vegetation at wadi banks or in major wadis. Within an area further west - inhabiting a few spots with vegetation - the variety of species was found to be very low (JV LI & ecoda 2013).

4.3.4.1 Flora

Vegetation cover in the project area was found to be extremely sparse and restricted to single drainage channels. Vegetation within the project area generally has a low species composition, density and a very patchy distribution. The wadis tend to support the most vegetation due to generally higher soil moisture levels. Permanent plants can only be found in

- smaller wadis crossing the project area from west to east in its northern part;
- Wadi Um Tinassib in the middle of the project area (near observation sites 10 and 11; see Chapter 4.3.4.2 and Map 4.2); and
- Wadi al-Hawwashiyah in the southern part of the project area (near observation site 12, Figure 4.12).

Plants found in the project area were mostly limited to very sparse communities of *Ochradinus baccatus*. These woody communities are widely distributed and can be found throughout the Arabian Desert, the coastal desert plains of the Red Sea and the Sinai Peninsula. In the project area, *O. baccatus* was found mostly in loose groups of bushes.

Another species which occurs in the project area is *Zygophyllum coccineum*. This species belongs to the succulent half shrub community and is widespread in the arid zones of Egypt. *Z. coccineum* is very common in limestone wadis and plains of the Eastern (Arabian) desert and tolerant of saline soils. Loose stands of this succulent xerophyte were found at different places scattered over the project area.

Higher numbers of small patches (1 to 2 m²) of *Ochradinus baccatus* and *Zygophyllum coccineum* are scattered at low density next to Suez-Hurghada road outside the project area.

Stipagrostis plumose was observed in the southern part of the project area. Grass cover may appear in the project area, but only after heavy rainfall. No tree or larger bush occurs within the project area.

During site visits a total of 36 species of xerophytic plant species that are typical for this part of the Eastern Desert were observed at major wadis in the project area and its wider surrounding (Table 4.2).

All species found within the project area are common and widespread in the Eastern Desert and, thus, not believed to be endangered or threatened. However, the conservational status of the mentioned species has not yet been assessed by an international or national Red List.



Figure 4.14: Scattered patches of vegetation in wadis in the middle and the north of the project area

Table 4.2: List of plant species recorded during site visits in and outside the project area during site visits

<i>Ephedra alata</i>	<i>Reseda alba</i>	<i>Tamarix nilotica</i>
<i>Haloxylon salicornicum</i>	<i>Farsetia aegyptia</i>	<i>Zygophyllum coccineum</i>
<i>Heliotropium digynum</i>	<i>Echinops spinosus</i>	<i>Phragmites australis</i>
<i>Panicum turgidum</i>	<i>Mesembranthemum forsskalei</i>	<i>Juncus rigidus</i>
<i>Centaurea aegyptiaca</i>	<i>Matthiola livida</i>	<i>Phoenix dactylifera</i>
<i>Anabasis setifera</i>	<i>Erodium pulverulentum</i>	<i>Leptadinia pyrotechnica</i>
<i>Thymus capitatus</i>	<i>Erodium gruina</i>	<i>Capparis decidua</i>
<i>Retama raetam</i>	<i>Acacia raddiana</i>	<i>Capparis cartilaginea</i>
<i>Zilla spinosa</i>	<i>Ziziphus spina-christii</i>	<i>Arthrocnemum sp.</i>
<i>Halocnemum strobilaceum</i>	<i>Moringa peregrina</i>	<i>Achillea fragrantissima</i>
<i>Ochradinus baccatus</i>	<i>Nitraria retusa</i>	<i>Atriplex halimus</i>
<i>Fagonia kahirina</i>	<i>Gymnocarpus decanderum</i>	<i>Launaea spinosa</i>

4.3.4.2 Fauna (except birds)

Despite the extreme aridity of the area, moderately diverse fauna is known to inhabit the vegetated wadis of the Red Sea Mountains and the Galala Plateau located at least 10 km west to the project area. This includes larger mammals such as Nubian Ibex (*Capra nubiana*) and Dorcas Gazelle (*Gazella dorcas*). However, both species are very unlikely to occur in the project site.

Mammals

In the northern region of the Eastern Desert mammals inhabit a variety of habitats, but are invariably associated in their distribution with the distribution and abundance of vegetation cover. Most species are found in vegetated wadis, where they forage in the wadi channel. Others inhabit rocky hillsides and mountain slopes. Flat gravel plains support very few mammal species, which are always restricted to the vegetated drainage channels in these plains.

Few mammals have been documented in the project area during the field work, indicating that diversity and density is very low because of the harsh living conditions in the desert. However, most animals are active at night, possibly another reason for the limited numbers of records. Moreover, aestivation is an adaption to very hot summer periods in several rodent species. Another reason for the low numbers of recorded mammals might be hunting.

Single Desert Red Foxes (*Vulpes vulpes pusilla*) were rarely observed in the south of the project area near observation site 11 and 12. However, tracks and two burrows of Desert Red Fox clearly show that this species belongs to the fauna of the southern part of the project area. The two burrows were located about 400 m east to observation site 11. Rüppell's Sand Fox (*Vulpes ruepelli*) was not encountered during field visits, but can rarely occur in the area, too. The same is valid for Domestic dogs (*Canis lupus familiaris*).

Based on data taken from literature one can expect that wolf-like Egyptian Jackal (*Canis aureus aureus*) cross the project area occasionally.

Rodents have not been observed in the project area, but signs left by these animals lead to the conclusion that rodent species do occur. Rodents are highly successful mammals, being capable of exploiting numerous ecological niches and exhibiting the greatest diversity among all mammals. Within the project area and its surrounding rodents are probably the most diverse mammalian order, represented by a total of 11 species. Species present in the area or at least strongly expected to live in the area are the Lesser Egyptian Jerboa (*Jaculus jaculus*), the widespread and abundant Greater and Lesser Egyptian Gerbil (*Gerbillus pyramidum*, *Gerbillus gerbillus*) and the nocturnal Cape Hare (*Lepus capensis*) (Osborne & Helmy 1980, Hoath 2003). The former three species could occur in numbers, while it is estimated that the latter one needs more vegetation than currently found.

All species found or expected to occur within the project area are considered as "Least Concern", i.e. no species is regarded to be threatened or endangered (according to the IUCN Red List of Threatened Species).

Reptiles

Reptiles are the most diverse vertebrate group in the desert habitats like the project area, and consist entirely of typical desert species. This herpetofauna is composed of lizards and snakes that are adapted to rocky and sandy desert habitats. According to Baha el Din (2006) about 15 to 25 species of the herpetofauna can be expected in the area around Ras Ghareb.

During site visits four species of reptiles were detected within the project area, of which one species belongs to the family *Gekkonidae*: Single specimens of Red Spotted Lizard (*Mesalina rubropunctata*) were observed occasionally at single spots in the project area, e.g. near observation point 8F.

Moreover, other members of the family *Gekkonidae* can be expected to occur in the project area, e.g. Bosc's Lizard (*Acanthodactylus boskianus*).

Two species of the family *Agamidae* were found within the project area:

- In autumn 2016, an Egyptian Dabb Lizard (*Uromastyx aegyptia*) was recorded between observation site 11 and 12. No burrow of this species was found within the project area. However, burrows are known to exist further west (see Figure 4.15 and JV LI & ecoda 2013). The Egyptian Dabb Lizard is considered to be "Vulnerable" (according to IUCN Red List of Threatened Species). As of yet there is no national Red List for reptiles. However, the Egyptian Dabb Lizard is formally protected by Egyptian legislation.
- A single individual of *Trapelus mutabilis*, Middle Eastern Agamid Lizard, occurred near observation sites 7.

A Sand Snake (*Psammophis aegyptius*) was encountered once, near observation site 5. This species is diurnal and preys on lizards and rodents which are actively hunted. Another species which is known to be common in coastal areas of sandy and rocky deserts and subdeserts and, hence, can probably also be found in the project area is Horned Viper (*Cerastes cerastes*).

As site visits were carried out during daytime, but most species of the herpetofauna are night active, the number of individuals and species might be underestimated.

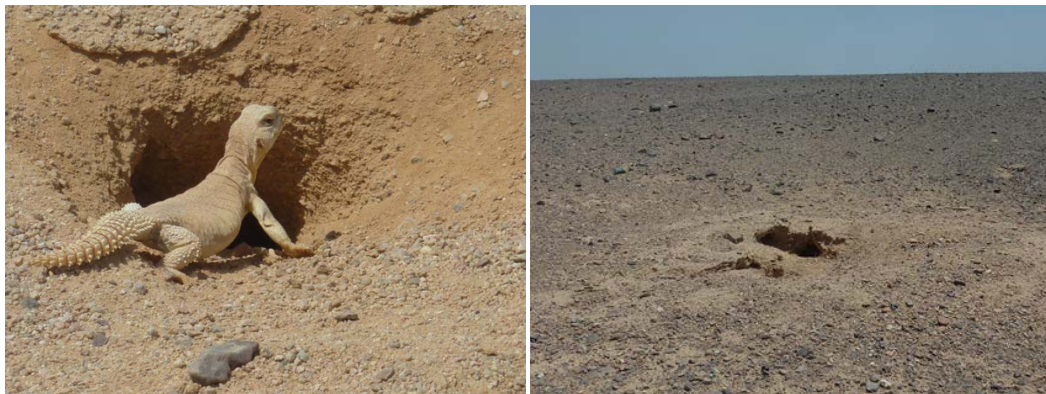

Figure 4.15: Egyptian Dabb Lizard at a burrow found outside of the project area (further west) in 2013

Insects

Invertebrate fauna of the project area is typical of that of the rocky and shallow sandy habitats of the Eastern Desert. Insects form the most diverse and numerically abundant invertebrate fauna in the project area. The site visits and examinations prior to, during or after bird observations did reveal that insects were occasionally quite abundant in the project area. During some bird observation periods (in times with low wind speed) bird watching was difficult due to hundreds of flies (mainly from the families *Muscidae*, *Syrphidae*) surrounding the observers.

Another local insect was the Desert Pebble Mantis (*Eremiaphila zetterstedti*) which was occasionally seen in the norther part of the area. Some other specimen from the families *Tenebrionidae* (Beetles), *Gryllidae* (Field Crickets), *Chrysopidae* (Lacewings) and *Noctuidae* (Moths) belong to local insect life, too.

Migratory insects were also encountered during field work: Mass migration was obvious in the Painted Lady Butterfly (*Vanessa cardui*), the Desert White (*Pontia glauconome*; see Figure 4.16) and the Vagrant Emperor Dragonfly (*Anax ephippiger*) which were regularly observed in the entire project area.

All insect species recorded within the project area are quite common throughout the Eastern Desert. None of the recorded species is known to be endangered or threatened.



Figure 4.16: Desert White (*Pontia glauconome*) and Camel Spider (*Galeodes arabs*) found in the project area

Table 4.3: List of animals (except birds) recorded during site visits or expected to occur in the project area

Class	Family	Species		Comment
Mammalia	<i>Canidae</i>	Desert Red Fox	<i>Vulpes vulpes pusilla</i>	recorded
	<i>Canidae</i>	Rüppell's Sand Fox	<i>Vulpes ruepelli</i>	expected
	<i>Canidae</i>	Domestic dogs	<i>Canis lupus familiaris</i>	expected
	<i>Dipodidae</i>	Lesser Egyptian Jerboa	<i>Jaculus jaculus</i>	expected
	<i>Muridae</i>	Greater Egyptian Gerbil	<i>Gerbillus pyramidum</i>	expected
	<i>Muridae</i>	Lesser Egyptian Gerbil	<i>Gerbillus gerbillus</i>	expected
	<i>Leporidae</i>	Cape Hare	<i>Lepus capensis</i>	expected
Reptilia	<i>Gekkonidae</i>	Red Spotted Lizard	<i>Mesalina rubropunctata</i>	recorded
	<i>Gekkonidae</i>	Bosc's Lizard	<i>Acanthodactylus boskianus</i>	expected
	<i>Agamidae</i>	Egyptian Dabb Lizard	<i>Uromastix aegyptia</i>	recorded
	<i>Agamidae</i>	Agamid Lizards	<i>Trapelus mutabilis</i>	recorded
	<i>Colubridae</i>	Sand Snake	<i>Psammophis aegyptius</i>	recorded
	<i>Viperidae</i>	Horned Viper	<i>Cerastes cerastes</i>	expected
Insecta	<i>Gryllidae</i>	Field crickets		recorded
	<i>Eremiaphilidae</i>	Desert Mantis	<i>Eremiaphila zetterstedti</i>	recorded
	<i>Nymphalidae</i>	Painted Lady	<i>Vanessa cardui</i>	recorded
	<i>Pieridae</i>	Desert White	<i>Pontia glauconome</i>	recorded
	<i>Noctuidae</i>	Heart and Dart	<i>Agrotis exclamationis</i>	recorded
	<i>Noctuidae</i>	Moths		recorded
	<i>Aeshnidae</i>	Emperor Dragonfly	<i>Anax ephippiger</i>	recorded
	<i>Chrysopidae</i>	Lacewings	<i>Chrysopa spec.</i>	recorded
	<i>Tenebrionidae</i>	Beetles		recorded
Arachnida	<i>Buthidae</i>	Desert Scorpion	<i>Androctonus australis</i>	recorded
	<i>Buthidae</i>	Deathstalker	<i>Leiurus quinquestriatus</i>	recorded
	<i>Buthidae</i>		<i>Orthochirus aristidis</i>	recorded
	<i>Salticidae</i>	Jumping Spiders		recorded
	<i>Solifugae</i>	Camel Spider	<i>Galeodes arabs</i>	recorded

Spiders

Three scorpion species have been recorded during site visits, namely *Androctonus australis*, *Leiurus quinquestriatus* and *Orthochirus aristidis*. These three species are venomous but do not represent a life-threatening hazard to adult humans.

Single individuals of Camel Spider (*Galeodes arabs*; see Figure 4.16) regularly occurred and most of the observation sites and can probably be found in the entire project area. Moreover, single specimens of the family *Salticidae* were rarely recorded in the project area.

None of the recorded species is known to be endangered or threatened.

Conclusion on threatened species (plants and animals)

Vegetation cover in the project area is extremely sparse and restricted to single drainage channels. The flora of the area is neither rich in species nor dense in populations. All species found within the project area are common and widespread in the Eastern Desert and, thus, not believed to be endangered or threatened. Hence, the importance of the project area as a habitat for plant species is very limited.

Few numbers of mammal, reptile and invertebrate species were recorded in the project area. Most species are quite common throughout the Eastern Desert. The only species of conservational concern is the Egyptian Dabb Lizard that is considered to be “Vulnerable” (according to IUCN Red List of Threatened Species). In addition, the Egyptian Dabb Lizard is formally protected by Egyptian legislation, and so are Rüppell's Sand Fox, Egyptian Jackal and Cape Hare. None of the other species recorded during site visits or expected to occur in the project area are known to be endangered or threatened. The area seems to be a rather suitable site for some reptile species of which most are quite common and widespread. For other species the habitat potential of the project area is rather limited.

4.3.5 Birds - Avifauna

4.3.5.1 Background, Aim and Main Approach

Parts of the Gulf of Suez, especially the area near Gabel el Zayt, are well known as a bottleneck for migrating birds from Europe and western Asia. Previous studies have shown that thousands of White Storks (*Ciconia ciconia*) and further thousands of raptors as well as other soaring species (e.g. Great White Pelican, *Pelecanus onocrotalus*) regularly migrate across the Red Sea Coast and the Red Sea Mountain Chain (Bergen 2009, Bergen & Gaedicke 2013, Carlbro 2010, ecoda 2007, 2011). Installing large wind farms in this region may lead to significant impacts on migrating birds caused by collisions with wind turbines or - to a lower degree - by barrier effects. Hence, a thorough impact assessment based on sound baseline data and, as far as required, implementation of effective mitigation measures are crucial when installing and operating wind farms at the Gulf of Suez.

On that background an extensive monitoring on migrating birds was conducted in accordance with the EIA guidelines and monitoring protocols for wind energy development projects in Egypt, which have been prepared in the scope of the Migratory Soaring Birds Project on behalf of the Ministry of State for Environmental Affairs and the Egyptian Environmental Affairs Agency (EEAA). The monitoring aimed to collect baseline data on migrating birds and to describe migration patterns of large soaring species (“target species”, see Annex I) within the project area in a quantitative way. On that basis likely impacts caused by multiple wind-farm projects within the 284 km² area can be identified and assessed and appropriate mitigation measures minimizing impacts can be defined.

The survey focussed on large soaring species (target species) as these birds have limited flight ability, are less manoeuvrable, have larger body sizes and spans and are therefore considered to be significantly more vulnerable by wind farms than other bird species. Nevertheless, other migrating species, local and roosting birds were recorded, too, to identify (if so) important breeding or roosting sites / habitats for vulnerable or endangered species.

The bird monitoring took place during three different migration periods and lasted

- from April 15th to May 25th, 2016 (comprising the 2nd half of spring migration period in 2016);
- from September 10th to November 10th, 2016 (comprising two third of autumn migration period in 2016); and
- from February 20th to May 20th (comprising full spring migration period in 2017).

Thus, the survey covered large parts of the main migration periods of target species (e.g. Bergen 2009, ecoda 2011, Lesham & Yom-Tov 1996).

Additional baseline data on the occurrence of migrating, roosting and local birds was made available from other investigations that took place in smaller plots located within the project area in 2015 and 2016:

- FiT-plot 3-4 (Alfanar): Bird Migration Study for 50 MW wind farm at Ras Ghareb in the Arab Republic of Egypt (ecoda 2016a):
 - a. autumn 2015: from September 26th and November 8th, 2015; and
 - b. spring 2016: from February 27th to May 26th, 2016.
- FiT-plots 5-4 and 6-4 (ACWA Power): Bird Migration Study for 100 MW wind farms at Ras Ghareb in the Arab Republic of Egypt (ecoda 2016b):
 - a. autumn 2015: from August 24th to October 5th, 2015; and
 - b. spring 2016: from February 27th to May 25th, 2016.
- FiT-plot 2-5 (Lekela): raw data made available by RCREEE (in the following: “Lekela-data” and “Lekela wind farm area”) covering
 - a. spring 2016: from February 10th to May 15th, 2016.

No data was made available for the autumn season.

The main results of these investigations are described in Chapters 4.3.5.3 and 4.3.5.4, the restrictions and main conclusions of these investigations are thoroughly considered in the assessment of the importance of project area and in the impact assessment (Chapter 5.3.4).

Finally, the results and main conclusions of a comprehensive bird monitoring (ecoda 2013) undertaken in the so-called 300 km² area which is located just (south)west of the project area will be considered in the assessment, too.

4.3.5.2 Methods

4.3.5.2.1 Standardized Observations of Migrating Birds

The investigation on migrating birds was based on standardized observations using fixed observation sites (see for instance Bergen 2009). Observations were conducted by three teams - each with two ornithologists - under guidance of a chief ornithologist, who advised and supervised the ornithologists from time to time. The teams consisted of European and Egyptian experts (see Annex III). With regard to the extent of the project area, a total of 14 observation sites were selected to obtain a representative sample of migration of large soaring birds within the project area (see Map 4.2).

As known from earlier studies many large soaring birds and especially flocks of birds can be recorded and safely identified at larger distances. However, detection probability of birds decreases with increasing distance to an observation site. Hence, data collection focused on the area at distances of 2.5 km to each observation site (= study area).

As earlier studies have shown (Bergen 2009, Bergen & Gaedicke 2013, Strix 2016), migratory activity is very low during early morning and late afternoon. Furthermore, during these periods of the day bird migration is dominated by species, which are more or less active flyers and, thus, do not depend on thermal uplifts (mainly Harriers). These species are not believed to be particularly vulnerable to collision with wind turbines. As a consequence, observations focused on the period from 1.5 hours after sunrise to 1.5 hours before sunset. In doing so, the daily period in which migratory activity is known to be highest was covered every day.

The time of the day was subdivided into morning, midday and afternoon. Two different rotation schedules were used to gain a representative distribution of spatial and temporal observation samples:

- Twelve observation sites were covered by two of the three teams. Each of the twelve observation sites was visited every second day for a period of 1.5 hours (in spring 2016) and 2.0 hours (in autumn 2016 and spring 2017), respectively. Hence, each day the two teams made observations at a total of six different sites (see Table 4.4).
- The third team carried out daily observations at sites 6F and 8F – each for 3.0 hours (see Map 4.2).

Most observation units started more or less at the planned time. Delays occurred but observation units were still within the range of the given period of the day.

Table 4.4: Rotation schedule applied at twelve of the 14 observation sites by two teams (MO= morning, MD= midday, A= afternoon)

observation site	1 st day	2 nd day	3 rd day	4 th day	5 th day	6 th day
1	MD		A		MO	
2	A		MO		MD	
3	MO		MD		A	
4		A		MO		MD
5		MD		A		MO
7		MO		MD		A
9	A		MD		MO	
10	MO		A		MD	
11	MD		MO		A	
12		A		MD		MO
13		MO		A		MD
14		MD		MO		A

Map 4.2
Overview of the location and bordering of project area, observation sites and study area

- Project Area**
- boundaries of the project area
 - existing roads
- Study Areas**
- observation site
 - RCREEE study area
 - Alfamar area
 - ACWA area
 - Lekela area (exact bordering unknown)

● editor: Lars Gaedicke, July 31st 2017

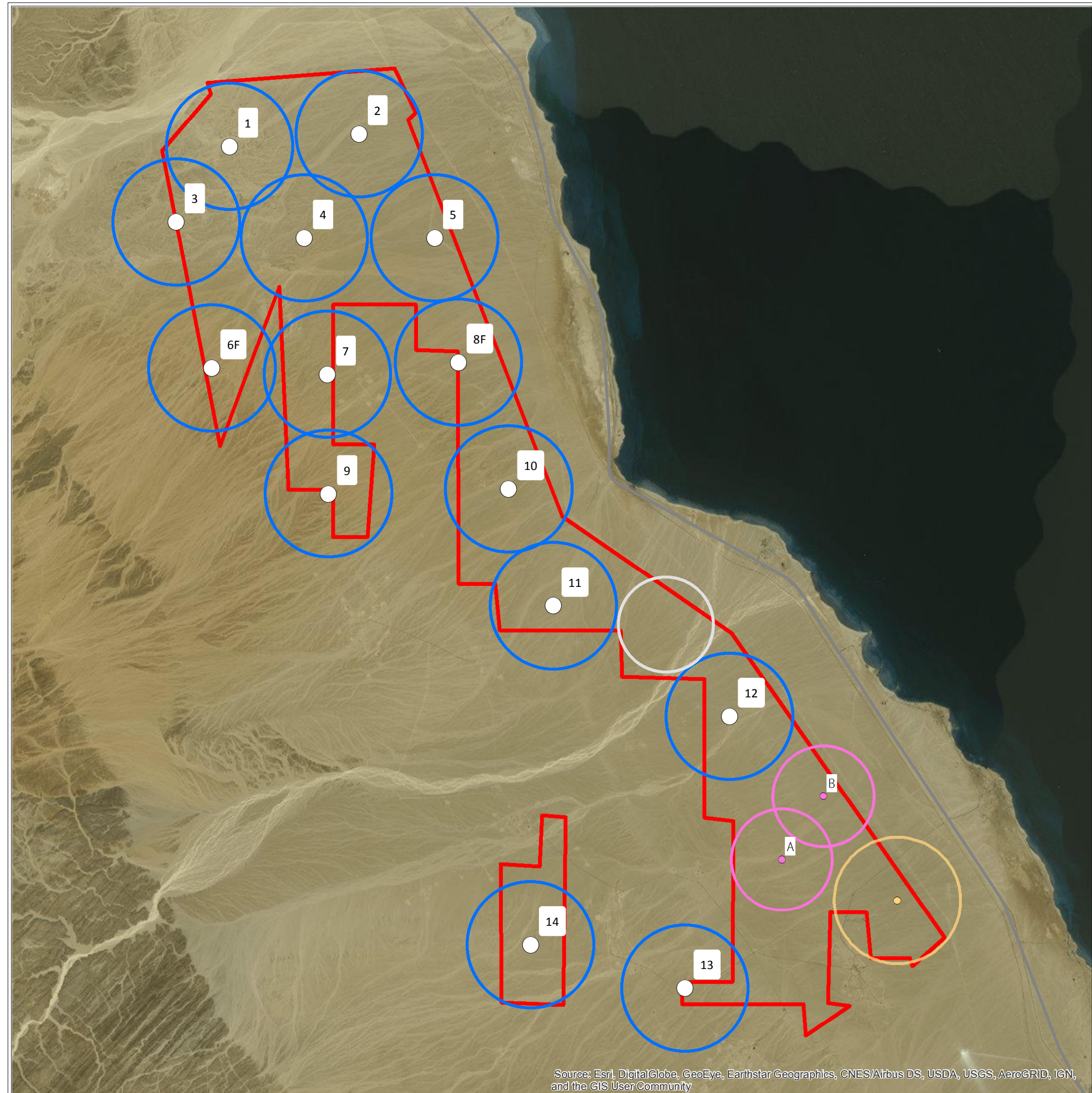

During an observation unit the experts “scanned” the horizon by binoculars with 8 - 10 times magnification as well as by telescopes with 20 - 60 times magnification. To increase data accuracy and to train ornithologists one Vector 21 Aero Laser Rangefinder (produced by vectronix©), with which the distance and height of a bird or a flock can be measured by a laser system, was used occasionally (see Figure 4.17).

Once a bird or a flock of birds was detected, the following variables were determined:

- Time of record
- Kind of species

Forsman (2016) and other adequate literature was used for species identification.

- Number of birds
- Distance and direction to the observation site

Conspicuous elements (e.g. powerline, infrastructure of petrol industry, further elements in the desert) and poles with attached red or blue flags (that made these poles highly visible, see Figure 4.18) and their distance to the observation sites were drawn in maps (after having taken their coordinates with a handheld GPS), which were used for the data collection. By these elements and poles (and the information of the distance to the observation sites) ornithologists were able to estimate the distance of birds fairly accurately. In addition the vector rangefinder was used to train the experts to estimate distance of birds to the observation sites.

- Flight direction and flight path

Flight directions of migrating large soaring birds were recorded by visual observations and occasionally by the vector rangefinder. Flight direction was estimated using eight classes (with an extension of 45° each): 1) north-northeast (NNE), 2) east-northeast (ENE), 3) east-southeast, ...

All flight paths of White Stork and Great White Pelican were recorded and schematically noted down on a map.

- Flight altitude

Flight altitude of each bird or flock of birds was estimated using three classes: 1) 0 - 30 m, 2) > 30 - 120 m, and 3) > 120 m. These heights were chosen because they are assumed to represent the rotor swept area (> 30 – 120 m) and the areas below (0 -30 m) and above the rotor swept area (> 120 m). The vector rangefinder was used to train the experts’ ability to estimate flight altitudes accurately.

At the beginning and at the end of each observation unit climatic conditions (temperature, wind speed (Bft) and wind direction using eight classes (see above), cloud cover (in %) and visibility were measured. For single days climatic conditions could not be measured due to technical problems with the measuring device. All variables and further information were recorded on a standard form and transferred to a database afterwards.

The observations were carried out almost exclusively during suitable conditions. During the vast majority of all observation units the ornithologists were able to see the full area within the 2.5 km radius around the observation sites.

The monitoring focused on long-lived species with low reproductive rates, late maturity and / or an unfavorable conservation status (threatened species) that are known to be particularly prone to collisions with wind turbines and that yearly use certain routes for migration. Populations of these target species are susceptible to any additional cause of mortality (Drewitt & Langston 2006). Species that do not meet the above mentioned criteria are classified as of “minor relevance” for the impact assessment, because the majority of such species are non-threatened passerines that have only a rather short life span and a high reproduction rate. During migration passerines do not concentrate in certain areas, but migrate on a broad front. In addition, passerines are not particularly prone to

collide at onshore wind turbines. As a consequence, wind power projects in the project area will not have a significant effect on populations of those species. Hence, a detailed consideration of these species in the impact assessment is not appropriate.

Single target species are of special interest within the impact assessment due to their status on the IUCN Red List of Threatened Species (see Annex I & II):

- Egyptian Vulture (*Neophron percnopterus*) and Steppe Eagle (*Aquila nipalensis*) are listed as “Endangered”.
- Greater Spotted Eagle (*Aquila clanga*) and Eastern Imperial Eagle (*Aquila heliaca*) are listed as “Vulnerable”.

In addition, further non-threatened species are considered:

- Pallid Harrier (*Circus macrourus*), Red-footed Falcon (*Falco vespertinus*) and Sooty Falcon (*Falco concolor*) are listed as “Near Threatened”.

All other target species are assessed to be of “Least Concern” by IUCN. Nevertheless, these species are also considered, as EEAA (2013) guidelines for the impact assessment for wind energy developments in Egypt point towards a consideration of common species like White Stork (*Ciconia ciconia*) or European Honey Buzzard (*Pernis apivorus*).



Figure 4.17: Experts during standardized observations in the study area



Figure 4.18: Pole with red flag used as a landmark for estimation of distances of birds/flocks to an observation site

4.3.5.2.2 Non-Standardized Observations

In addition to the standardized observations data collection covered also:

- migrating birds of target species, which were recorded by chance / randomly, e.g. before or after an observation unit or while driving through the project area;
- migrating birds of species of minor relevance (see above), which were recorded either during an observation unit or by chance / randomly, e.g. before or after an observation unit or while driving through the project area; and
- local and roosting birds (either from target species or from species of minor relevance), which were recorded either during an observation unit or by chance / randomly, e.g. before or after an observation unit or while driving through the project area.

If ever a bird of one of these groups was detected, the following variables have been recorded: date, time, location, species and number of birds.

4.3.5.2.3 Site Visits on Roosting and Local Birds

The approach for data collection on roosting and local birds was designed according to the characteristics and extent of the project area as well as to the abundance and distribution of birds likely to occur in a desert habitat. Combined transect- / point-counts with mainly direct observations can be regarded as the most appropriate method providing a standardized technique of counting birds within such an area. Transect selection was done due to the characteristics landscape of the project area focusing on wadis, areas surrounding existing roads, tracks and access paths to the observation sites. During site visits conducted in spring and summer 2017 the expert slowly drove with a 4x4 Land Cruiser along the selected transects in search of present local birds. At certain locations the surrounding was “scanned” with a binocular.

During site visits (i.e. systematic transect counts, standardized and non-standardized observations; see above) every observation of roosting or local birds was recorded (number of individuals, species, sex, behaviour). Collins bird guide was used for strengthening species identification.

4.3.5.2.4 Data Analysis

Observational Time Spent for Standardized Observations

The analysis for spring 2016 comprises 280 observation units. These observation units were equally distributed over 35 days. The total observational time amounts to 525 hours. With only one exception, it was possible to follow the schedule: On April 15th only seven observation sites were visited, at one observation site two observation units were carried out (instead of one).

The analysis for autumn 2016 comprises 425 observation units which were equally distributed over 54 days. The total observational time amounts to 950.3 hours. Due to heavy rainfalls on October 27th three observation units were aborted. On October 29th, 30th and 31st field ornithologists could not reach parts of the project area because heavy rainfalls had caused damage and flooding. Thus, six observation units had to be cancelled. Moreover, the teams had to search for alternative routes to reach certain observation sites. For that reason, four observation units started later than originally scheduled (about one hour or somewhat more). The teams decided to shorten these four observation units in order to begin the other observation units in time.

In spring 2017 observations were carried out during 77 days. A total of 604 observation units were conducted. The observational time summed up to 1,351.1 hours. On April 23rd afternoon one observation had to be aborted because of a commencing sandstorm. On the next day the teams visited the study area, but could not conduct observations as planned due to the ongoing sandstorm. A total of seven observation units were cancelled. One team withstood the conditions for about 35

min, but had to abort the observation unit. On May 13th again a sandstorm hindered the observations. During the morning each of the three teams observed for one hour and then stopped the observations, thus three observation units were shortened. Another five observation units had to be cancelled.

Standard Data Set on Migrating Birds

From each overall dataset obtained during standardized observations in spring 2016, autumn 2016 and spring 2017 only those migrating birds/records of target species were selected and taken over into the standard data sets that were registered at distances of up to 2.5 km from the observation sites. In doing so, it was secured that most birds migrating within this area at relevant altitudes had been detected and properly identified (see Chapter 4.3.5.2.1). Moreover, this approach is beneficial, because the obtained numbers can be clearly related to a certain area.

Each of the three data sets was further analysed with regards to the following aspects:

- Correction for Possible “Double Counts”

Observations were carried out synchronously at various sites within the project area by the three teams of experts. Thus, the three team-approach might lead to so-called “double counts” (i.e. a single bird or a flock was recorded twice (by two teams) or even three times (by three teams) at different observation sites) and, hence, causing an overestimation of the total number of migrating soaring birds. The experts tried to identify situations in which double counts may have occurred already in the field by communicating via mobile phone (each team was aware of the position of the other teams). In addition, raw data was checked and obvious double counts were deleted from each data set (spring 2016, autumn 2016 and spring 2017) to minimize a possible overestimation of migrating birds. Double counts of large flocks that have a huge effect on the number of birds could easily be detected, while the detection of double counts of single birds was more difficult. However, the effect on single birds is not believed to have a relevant effect on the data sets and, hence, can be neglected in further analysis.

- Migratory Rate as a Measure for Migratory Activity

In order to describe migratory activity we calculated average migration rate (birds per hour and records per hour; hereafter: birds/h and records/h) for each observation site and for each migration season. In doing so, the arithmetical mean and the according standard deviation was used firstly. However, as data on ecological subjects recorded in the field usually not follow a normal distribution, the explanatory power of the arithmetical mean is weak. For that reason, the so-called median and the according 1st and 3rd quartile was used as a measure for average migration rate.

- Number of migrating birds, species composition and flock size

In order to characterize bird migration, the total number of birds for each target species was calculated. In addition, the number of records was used as a further variable to describe migration patterns. A single record can either be an individual or a flock (independent of the number of birds). The number of records is an important variable because it is independent from flock size. In contrast, a single but large flock has a strong effect on the variable “number of birds”. Therefore, the number of records gives additional information about migratory activity and continuity as well as on species-specific migration behaviour.

A species-specific extrapolation of the overall number of birds that likely migrated through the study area during a full migration season is not believed to come to reasonable results, i.e. realistic numbers (as is shown in Chapter 4.3.4.4.6). For that reason no attempt was undertaken to estimate the overall numbers of target species.

- Seasonal distribution of migratory activity

To identify peak migration periods the cumulative number of birds/records was plotted over time. By summing up the number of birds/records and considering the observational time for every week during the study period a weekly migratory activity (number of birds/records by weekly observation time) was calculated.
- Daily distribution of migratory activity

To analyse migratory activity during the day, migration rate (birds/h and records/h) was calculated for each observation unit. Subsequently, for 12 of the 14 observation sites these values were averaged (arithmetical mean and standard deviation) for each of the three daily periods (morning, midday and afternoon). At sites 6F and 8F an observation unit either covered morning and first part of midday or second part of midday and afternoon. Hence, mean migration rates at these two sites were calculated only for two periods (morning-midday and midday-afternoon).
- Altitude of migration

Regarding possible impacts of wind turbines on migrating birds, flight altitude is a very important variable. To analyse the vertical distribution of migrating target species, the number of birds/records was summed up for each altitude class (0 – 30 m, >30 – 120 m, > 120 m) – differentiating between maximum and minimum altitude. In single cases flight altitude was not determined precisely, because birds were seen for only a very short period of time. For that reason sample size might be lower than in the overall data set.
- Flight direction

Flight direction was reclassified into north (NNW, NNE), west (WNW, WSW), south (SSW, SSE) and east (ENE, ESE). Afterwards the number of birds/records per flight direction was summed up.
- Spatial comparison of migratory activity

To identify any (if at all) spatial differences in migratory activity and to assess the importance of different parts (i.e. observation sites) of the project area for migration of large soaring species, migration rates (birds/h and records/h) was calculated for each observation unit. Subsequently, these values were averaged (arithmetical mean and standard deviation) for each observation site over each study period enabling a comparison of migratory activity at the 14 observation sites.

Since migratory activity does usually not follow a normal distribution the arithmetical mean might not be a reasonable measure for describing bird migration at a single site. Hence, in some cases the median (in combination with 1st and 3rd quartile) was used as a descriptive measure, too.

In addition, the specific rotation schedule regularly led to synchronized observations (with comparable independent variables (e.g. weather conditions or time of day)) at certain particular pairs of observation sites (1 & 9, 2 & 10, 3 & 11, 4 & 12, 5 & 13, 7 & 14). This gives the opportunity to test (by using Wilcoxon signed-rank test for paired samples) whether migration rates at the two sites of each pair significantly show a difference.
- Assessment of migratory activity

To assess migratory activity and the significance of the project area for bird migration of large soaring species in autumn and spring, the results obtained in the monitoring were compared to results of previous studies conducted at the Red Sea between 2006 and 2016 (Bergen 2009, Bergen & Gaedicke 2013, ecoda 2007, 2011, 2016a, 2016b).

Conclusions gained by a comparison of migration rates from different surveys always have to be treated carefully. As circumstances (year, area, observers, time of observation, climatic conditions etc.) differ, a one-to-one comparison is rarely possible. Nevertheless, a rough assessment of migratory activity can be achieved.

- Wind speed and wind direction during standardized field observations

Within weather variables wind speed and wind direction are supposed to have the strongest effect on bird migration of large soaring birds. To consider this effect on migratory activity, averaged wind speed was firstly calculated for every single observation unit by the results obtained at the beginning and at the end of each unit. Afterwards average wind speed was allocated to one of three classes for wind speed:

wind speed	in Bft
low	0 to 3
medium	> 3 to 5
high	> 5

Wind direction was reclassified into north (NNW, NNE), west (WNW, WSW), south (SSW, SSE) and east (ENE, ESE). If wind direction was similar at the beginning and at the end of an observation unit, this certain wind direction was used. If wind direction differed, it was classified as “changing”.

Migrating soaring birds are known to prefer certain weather conditions in general and certain wind conditions in particular (e.g. Shamoun-Baranes et al. 2003, Shamoun-Baranes et al. 2006, Vansteelant et al. 2015, Vidal-Mateo et al. 2016). Against this background it was analysed whether wind conditions had an effect on the number of migrating birds.

As bird migration strongly depends on the intrinsic migratory state of a bird / of birds (Newton 2008), the effect of prevailing weather conditions (mainly wind conditions) on migratory activity at a certain place can only roughly be assessed. For instance, after a hold-up or late in the migration season birds may start migrating even in conditions that, at other times, would stimulate little or no migration. This example matches in particular for the spring season when birds need to reach the breeding sites in time. Moreover, at the end of a migration season favourable conditions are unlikely to have an effect on migratory activity, when most birds have already passed.

The results of the species specific evaluation are given in Annex IV (species-specific factsheets). An overview of the number/records of birds registered at the 14 observation sites in each of the three study periods is given in Annex V.

As already given above, parts of the project area (see Map 4.2) have been investigated in autumn 2015 and spring 2016 by private investors: Alfanar (ecoda 2016a), ACWA Power (ecoda 2016b) and Lekela (unpubl. data). The available data obtained by these surveys was - as far as possible - also analysed in the way described above (see Chapters 4.3.4.3, 4.3.4.4, 4.3.4.5 and 4.3.4.6).

Non-Standardized Data Set and Data Set on Roosting and Local Birds

No further analysis was undertaken for this dataset that consists of migratory soaring birds of target species recorded by chance / randomly, e.g. before or after an observation unit or while driving through the project area. Nevertheless the data is presented in Chapters 4.3.4.3 and 4.3.4.4 and - as far as meaningful - considered in the assessment.

No further analysis was undertaken for this dataset that consists of local and roosting birds (either from target species or from species of minor relevance), which were recorded either during an observation unit or by chance / randomly, e.g. before or after an observation unit or while driving through the project area. Nevertheless the data is presented in Chapters 4.3.4.5 and 4.3.4.6 and considered in the assessment.

4.3.5.3 Results on Migrating Birds in Autumn

4.3.5.3.1 Project Area in Autumn 2016

Number of Migrating Birds, Species Composition and Flock Size

During the study period in autumn 2016, i.e. from September 10th to November 10th, 2016, a total of 2,437 birds from 23 target species occurred at distances of up to 2.5 km to the observation sites (Table 4.5). European Honey Buzzard, White Stork and Great White Pelican were the most numerous species, representing about 91 % of all registered individuals.

Table 4.5: Number of birds and records registered in the study area (i.e. at distances of up to 2.5 km from the observation sites) in the study period (September 10th to November 10th) in autumn 2016

species	scientific name	birds	records
Great White Pelican	<i>Pelecanus onocrotalus</i>	244	3
White Stork	<i>Ciconia ciconia</i>	636	5
European Honey Buzzard	<i>Pernis apivorus</i>	1,335	148
Black-winged Kite	<i>Elanus caeruleus</i>	2	1
Black Kite	<i>Milvus migrans</i>	37	28
Short-toed Snake Eagle	<i>Circaetus gallicus</i>	1	1
Marsh Harrier	<i>Circus aeruginosus</i>	31	27
Pallid Harrier	<i>Circus macrourus</i>	11	11
Montagu's Harrier	<i>Circus pygargus</i>	11	10
Pallid / Montagu's Harrier	<i>Circus macrourus / pygargus</i>	5	5
Harrier	<i>Circus spec.</i>	1	1
Levant Sparrowhawk	<i>Accipiter brevipes</i>	20	4
Eurasian Sparrowhawk	<i>Accipiter nisus</i>	2	2
Steppe Buzzard	<i>Buteo buteo vulpinus</i>	25	10
Long-legged Buzzard	<i>Buteo rufinus</i>	3	2
Buzzard	<i>Buteo spec.</i>	1	1
Steppe Eagle	<i>Aquila nipalensis</i>	3	3
Booted Eagle	<i>Aquila pennata</i>	3	3
Lesser Kestrel	<i>Falco naumanni</i>	3	3
Common Kestrel	<i>Falco tinnunculus</i>	10	10
Lesser / Common Kestrel	<i>Falco naumanni / tinnunculus</i>	1	1
Red-footed Falcon	<i>Falco vespertinus</i>	4	2
Eleonora's Falcon	<i>Falco eleonora</i>	1	1
Sooty Falcon	<i>Falco concolor</i>	28	19
Eurasian Hobby	<i>Falco subbuteo</i>	1	1
Lanner Falcon	<i>Falco biarmicus</i>	3	3
Saker Falcon	<i>Falco cherrug</i>	2	1
Falcon	<i>Falco spec.</i>	4	4
unidentified raptor	-	9	8
total		2,437	318

Classification due to IUCN Red List of Threatened Birds: "Endangered", "Near Threatened". Species listed as "Least Concern" or not considered in the IUCN Red List are not colored.

A total of 318 records (of an individual or a flock) were registered at distances of up to 2.5 km to the observation sites. European Honey Buzzards were registered most often (47 % of all records). By contrast, Great White Pelican and White Stork were observed only 3 and 5 times, respectively.

No large flock (with > 1,000 individuals) appeared in the study period in autumn 2016. Larger flocks (101 - 1,000 individuals) were rarely recorded, but had a strong effect on the dataset: three larger flocks (0.9 % of all records) representing about 28 % of all migrating birds (Figure 4.19). In contrast, the fraction of birds migrating individually made up about 55 % of all records, yet about 7 % of all birds (Figure 4.19).

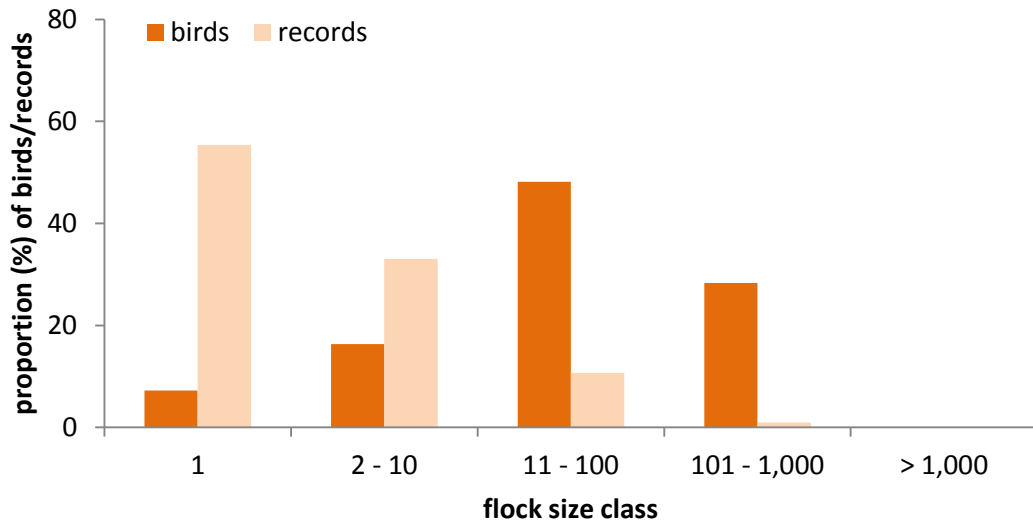

Figure 4.19: Relative abundance (proportion in %) of all birds/records registered at distances of up to 2.5 km in different flock size classes in the study period in autumn 2016

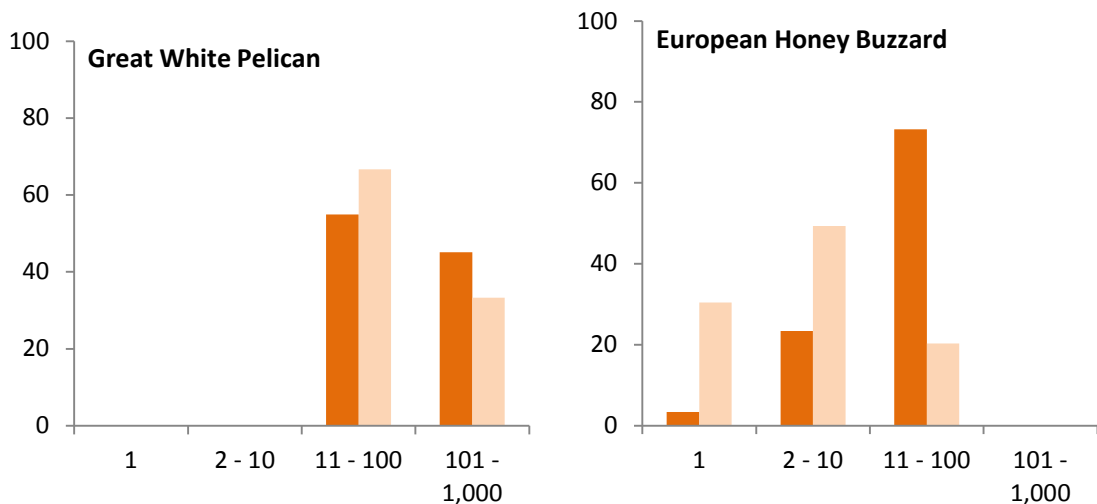

Figure 4.20: Relative abundance (proportion in %) of birds (orange) / records (light orange) of selected species in different flock size classes in the study period in autumn 2016

During the study period one species of special interest within the impact assessment (due to its status on the IUCN Red List of Threatened Species, see Chapter 4.3.5.2.1) appeared in the study area: Steppe Eagle (see Table 4.5). In addition the “Near Threatened” species Pallid Harrier, Red-footed Falcon and Sooty Falcon were recorded.

When interpreting the results it is important to consider that the first three weeks of the autumn migration period were fully missed due to the late start of the survey. As known from other investigations the first three weeks (i.e. from mid / end of August to mid of September) are most important for autumn migration (see Figure 4.28 in Chapter 4.3.5.3.3).

Seasonal Distribution of Migratory Activity

Migration rate (birds/h and records/h) was relatively high in the first two weeks of the study period (Figure 4.21). A total of 91 % of all birds and 63 % of all records were registered in these two weeks. Subsequently migratory activity rapidly fell down and remained at a very low level up to the end of the survey. The obtained phenology was mainly caused by a more or less constant migration of European Honey Buzzards and rare flocks of Great White Pelican and White Stork during the first two weeks.

Due to the late start of the survey main migration periods of single species (e.g. White Stork) were not fully covered. Thus, it is questionable whether the number of White Stork recorded during the study period was representative for autumn migration. Even from other species (e.g. European Honey Buzzard and Great White Pelican) numbers of birds might have already passed the area in August and early September.

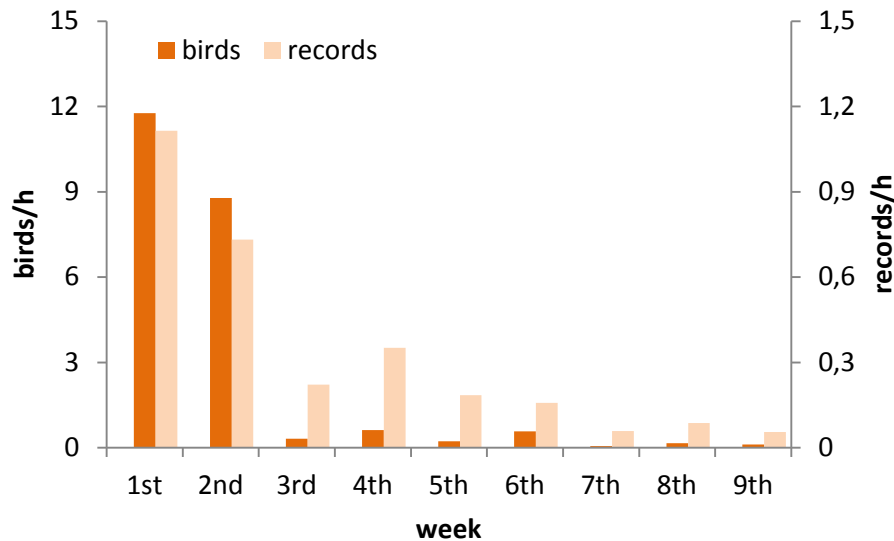

Figure 4.21: Migratory activity (birds/h and records/h) in different weeks of the study period (September 10th to November 10th) in autumn 2016 (only birds at distances of up to 2.5 km to the observation sites; to correct different observational time the number of birds/records was divided by observational time of the particular week; 1st week: September 10th to 15th)

Daily Distribution of Migratory Activity

Daily activity of large soaring birds was highly variable during the study period in autumn 2016 (see Figure 4.22). Considering the high standard deviation there were no remarkable differences in migration rates during morning, midday and afternoon. Considering the median as a measure for daily distribution of migratory activity during the day it becomes apparent that most of the time migration was (very) low: During the morning the median was 0.3 birds/h at 12 sites, whereas it was equal to zero for all other cases (i.e. midday and afternoon at 12 sites; morning-midday and midday-afternoon at sites 6F and 8F).

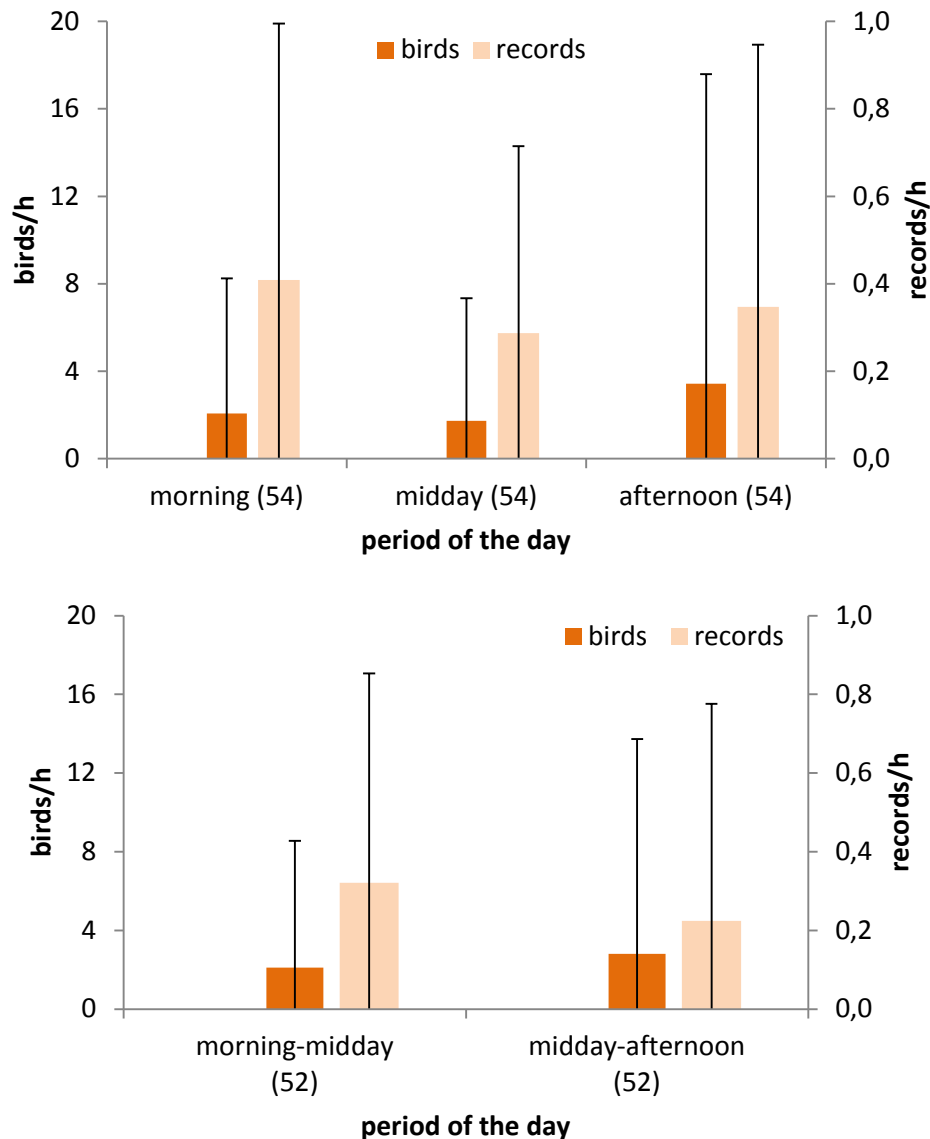

Figure 4.22: Average migratory activity (birds/h and records/h) at distances of up to 2.5 km to the observation sites during different periods of the day in autumn 2016 (for sites 6F and 8F (below) and for all other 12 sites (above); arithmetical mean and standard deviation; sample size (i.e. no. of observation days) for each period is given in brackets)

Altitude of Migrating Birds

In autumn 2016 about 74 % of all birds and 48 % of all records were recorded at altitudes above 120 m (Table 4.6). 24 % of all birds and 38 % of all records were - at least temporary - registered at altitudes from 30 to 120 m (roughly representing the rotor swept area of wind turbines). Only few birds/records migrated exclusively at altitudes below 30 m.

Steppe Eagles, considered as “Endangered” (see above), were registered at all altitude classes. This is also valid for Pallid Harrier and Sooty Falcon (both “Near Threatened”). However, the majority of Sooty Falcons occurred exclusively at altitudes below 30 m. All recorded Red-footed Falcons migrated exclusively at altitudes above 120 m through the study area.

Table 4.6: Number of birds (above) and records (below) observed at distances of up to 2.5 km to the observation sites at different flight altitude classes registered in autumn 2016

		flight altitude maximum (in m)		
		< 30 m	> 30 - 120 m	> 120 m
flight altitude minimum (in m)	birds			
	< 30 m	59	15	63
	> 30 - 120 m		210	298
	> 120 m			1,792
		flight altitude maximum (in m)		
		< 30 m	> 30 - 120 m	> 120 m
flight altitude minimum (in m)	records			
	< 30 m	45	14	7
	> 30 - 120 m		66	33
	> 120 m			153

Flight Direction

As usual during the migration period in autumn, the majority of birds (about 86 %) and records (about 81 %) migrated in southern directions. About 13 % of all birds and 15 % of all records headed for western directions.

Spatial Comparison of Migratory Activity

At first sight the spatial analysis suggests a higher average migration rate (birds/h) at observation site 5 (Figure 4.23). However, the large standard deviation clearly shows that the arithmetical mean is not a reliable measure to describe migratory activity at the 14 observation sites. The result was strongly affected by a single flock of 380 White Storks recorded near observation site 5 (see Map 4.3) leading to a high arithmetical mean at that observation site.

Migration rates at the 14 observation sites varied between 0.2 and 0.5 records/h and. Thus, no remarkable differences appeared when considering records/h as a measure for migratory activity.

Considering the median it becomes apparent that most of the time migratory activity was (very) low. At all observation sites no bird was recorded in more than half of the observation units and, hence, the median was equal to zero (both, for birds/h and records/h).

No significant difference in migration rates (birds/h and records/h) was detected during synchronous observation units at two sites by application of Wilcoxon signed-rank test (Table 4.7).

To conclude, the results clearly show that there exist no preferred flight paths or no areas avoided by large soaring birds during autumn migration. Though the terrain is rising to the west and though the project area is somewhat hilly in its northern part, there are no remarkable topographic features which affect the spatial distribution of large soaring birds in autumn. To conclude, no spatial differentiation can be made when describing and assessing migratory activity in the project area in autumn.

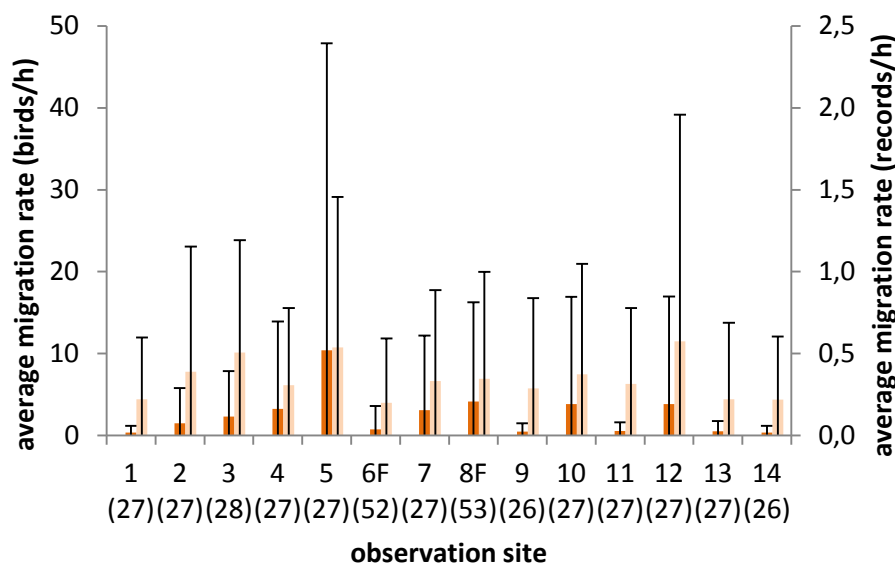
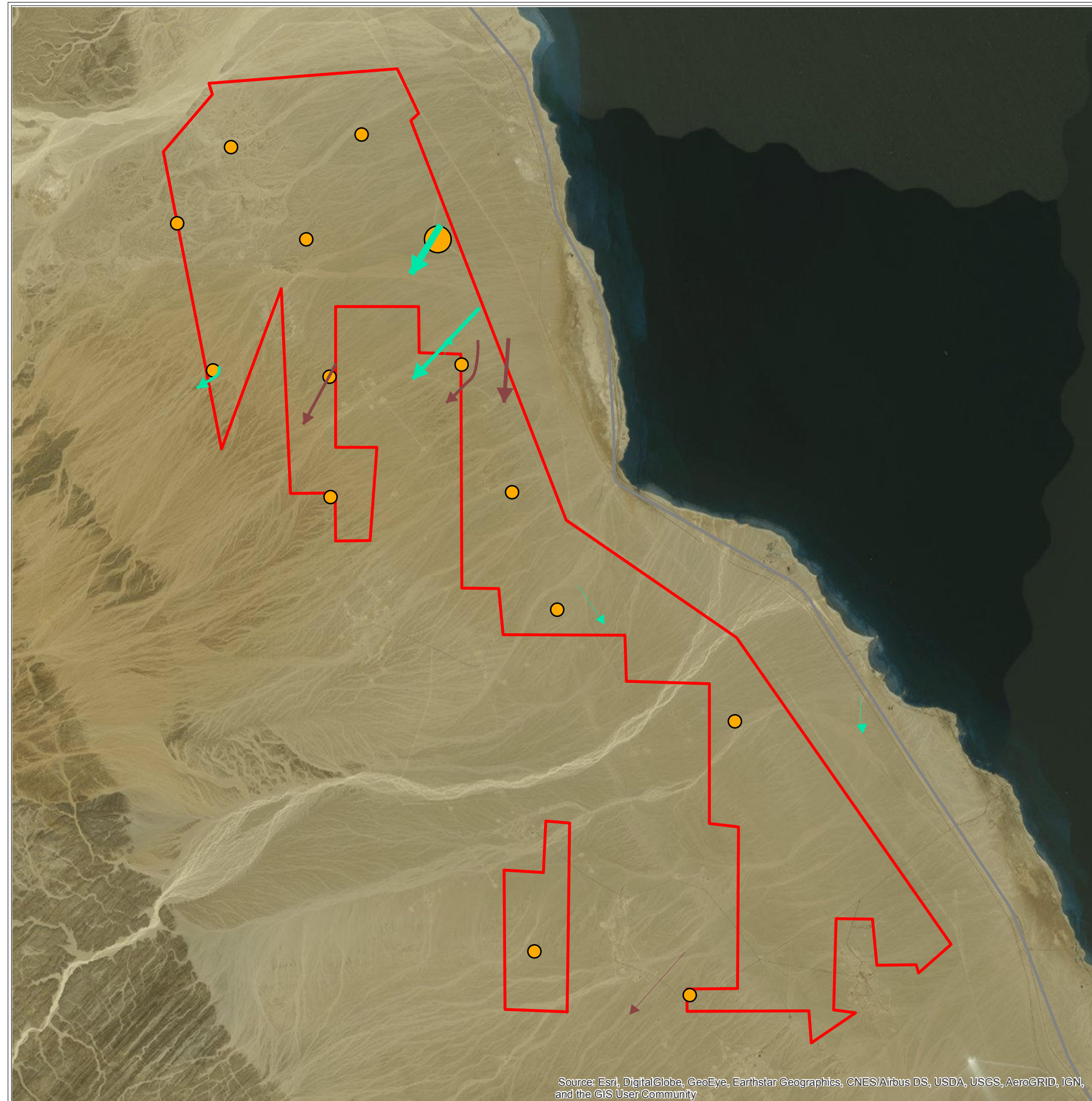

Figure 4.23: Comparison of migration rates (birds/h (orange) and records/h (light orange)) at the 14 observation sites in the study period (September 10th to November 10th) in autumn 2016 (arithmetic mean and standard deviation over all observation units; sample size (i.e. no. of observation units) at each observation site is given in brackets)

Table 4.7: Comparing migration rate (birds/h and records/h) at observation sites during synchronous observation units (results of Wilcoxon signed-rank test for paired samples: significant difference would exist, if $p < 0.05$)

pair of obs. sites	birds/h		records/h	
	V	p	V	p
1 / 9	14.5	0.673	11.0	0.670
2 / 10	28.0	0.689	27.0	1.000
3 / 11	74.5	0.176	50.5	0.356
4 / 12	45.5	0.283	20.5	0.502
5 / 13	59.5	0.115	35.5	0.137
7 / 14	93.5	0.060	58.5	0.373

Map 4.3
Mean migration rate of target species (birds/h) at the 14 observation sites and flight paths of Great White Pelicans and White Storks in autumn 2016



Project Area

- boundaries of the project area
- existing roads

Mean Migration Rate

- < 5.0 birds/h
- 5.0 to 11.0 birds/h

Flight Paths of

- Great White Pelican
- White Stork

Number of Birds

- 1 to 10 individuals
- 11 to 100 individuals
- 101 to 200 individuals
- 380 individuals

● editor: Lars Gaedicke, July 31st 2017

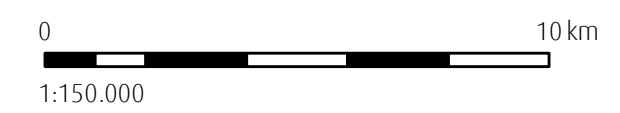

Wind Speed and Wind Direction

In autumn 2016 strong wind from northern directions was dominant during most observation units (Figure 4.24).

Taken into account that soaring birds prefer migrating in tailwinds situations (e.g. Vansteelant et al. 2015) the conditions in the study area in autumn 2016 were (very) suitable during almost the entire study period. Nevertheless, the total number of migrating birds was comparably low. There was no noticeable relationship between migratory activity and prevailing wind conditions in the study area. Apparently, other factors than wind speed or wind direction affected migratory activity.

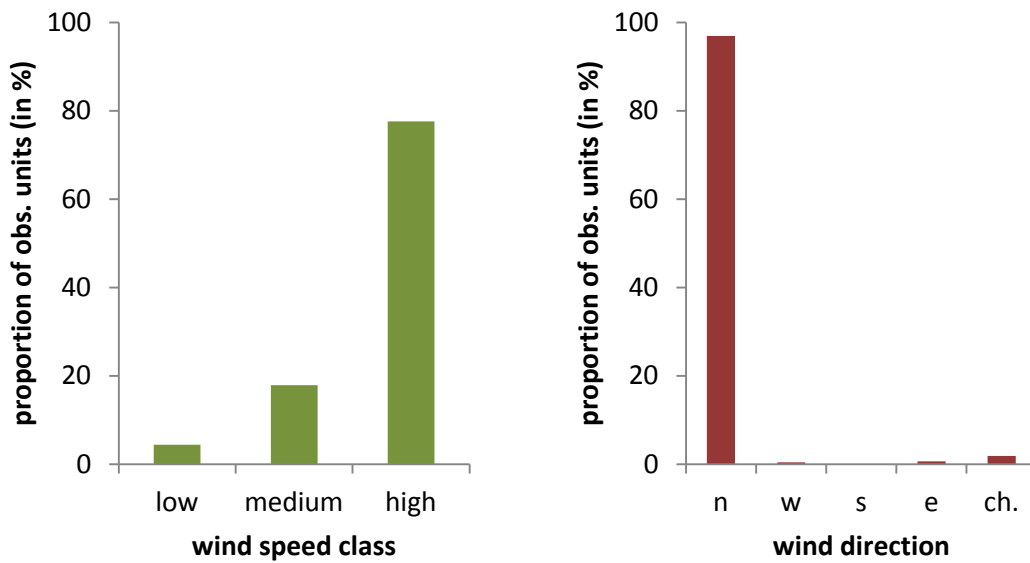

Figure 4.24: Wind speed (left) and wind direction (right) obtained in the study area in autumn 2016 (ch.= changing)

Other Observations of Migrating Birds

Single large soaring birds were recorded by chance (i.e. not during standardized observations) in the project area in autumn 2016 (Table 4.8). In addition, migrating birds of species that are of minor relevance for the impact assessment were occasionally recorded during standardized observation units or by chance in the project area (Table 4.8).

Table 4.8: Number of migrating birds of species that are of minor relevance for the impact assessment or of target species that were randomly recorded in the project area

species	scientific name	birds
Great White Pelican	<i>Pelecanus onocrotalus</i>	5
Great Cormorant	<i>Phalacrocorax carbo</i>	765
Grey Heron	<i>Ardea cinerea</i>	1
European Honey Buzzard	<i>Pernis apivorus</i>	24
Marsh Harrier	<i>Circus aeruginosus</i>	3
Montagu's Harrier	<i>Circus pygargus</i>	1
European Bee-eater	<i>Merops apiaster</i>	91
Bimaculated Lark	<i>Melanocorypha bimaculata</i>	139
Lark spec.	-	37
Sand Martin	<i>Riparia riparia</i>	2
Barn Swallow	<i>Hirundo rustica</i>	48
Eurasian Reed Warbler	<i>Acrocephalus scirpaceus</i>	2
Willow Warbler	<i>Phylloscopus trochilus</i>	10
Common Chiffchaff	<i>Phylloscopus collybita</i>	3
Warbler spec. (Phylloscopus)	<i>Phylloscopus spec.</i>	2
Lesser Whitethroat	<i>Sylvia curruca</i>	3
Black Redstart	<i>Phoenicurus ochruros</i>	1
Northern Wheatear	<i>Oenanthe oenanthe</i>	2
Mourning Wheatear	<i>Oenanthe lugens</i>	5
Pied Wheatear	<i>Oenanthe pleschanka</i>	1
White Wagtail	<i>Motacilla alba</i>	40
Yellow Wagtail	<i>Motacilla flava spec.</i>	2
Wagtail spec.	<i>Motacilla spec.</i>	1
Red-throated Pipit	<i>Anthus cervinus</i>	7

4.3.5.3.2 Alfanar Area in Autumn 2015

Number of Migrating Birds, Species Composition and Flock Size

During standardized field observations in autumn 2015, lasting from September 26th to November 8th, only very few large soaring birds were recorded at distances of up to 2.5 km to the observation site in the Alfanar area: 138 birds from 15 relevant species (Table 4.9). This result was clearly caused by the late start of the survey. The first five weeks of the autumn migration period were fully missed. As known from other investigations the first three weeks (i.e. from mid / end of August to mid of September) are most important for autumn migration (see Figure 4.24 in Chapter 4.3.4.3.3).

The most numerous species were Great White Pelican (2 flocks) and Common Crane (1 flock). No larger flock with 100 individuals or more was recorded in the Alfanar area in the study period in autumn 2015.

During autumn 2015 no species was recorded in the Alfanar area that is considered as “Critically Endangered”, “Endangered” or “Vulnerable” (according to the IUCN Red List). One “Near Threatened” species was observed: Sooty Falcon with a total of four individuals.

Table 4.9: Number of birds and records registered in the Alfanar area (i.e. at distances of up to 2.5 km to the observation site) in the study period (September 26th to November 8th) in autumn 2015

species	scientific name	birds	records
Great White Pelican	<i>Pelecanus onocrotalus</i>	51	2
Grey Heron	<i>Ardea cinerea</i>	1	1
White Stork	<i>Ciconia ciconia</i>	3	1
European Honey Buzzard	<i>Pernis apivorus</i>	1	1
Black Kite	<i>Milvus migrans</i>	7	6
Marsh Harrier	<i>Circus aeruginosus</i>	6	5
Montagu's Harrier	<i>Circus pygargus</i>	2	2
Pallid / Montagu's Harrier	<i>Circus macrourus / pygargus</i>	2	1
Eurasian Sparrowhawk	<i>Accipiter nisus</i>	2	2
Buzzard	<i>Buteo spec.</i>	1	1
Lesser Spotted Eagle	<i>Aquila pomarina</i>	3	3
Bonelli's Eagle	<i>Aquila fasciata</i>	1	1
Common Kestrel	<i>Falco tinnunculus</i>	13	12
Sooty Falcon	<i>Falco concolor</i>	4	3
Lanner Falcon	<i>Falco biarmicus</i>	3	2
Peregrine Falcon	<i>Falco peregrinus</i>	1	1
Common Crane	<i>Grus grus</i>	36	1
unidentified raptor	-	1	1
total		138	46

Classification due to IUCN Red List of Threatened Birds: “Near Threatened”. Species not considered in the IUCN Red List are not colored.

Seasonal Distribution of Migratory Activity

In autumn 2015 migratory activity was low during the whole study period (Figure 4.25). A peak in the third week (considering birds/h) was caused by a flock of 36 Common Cranes on October 10th and a flock of 50 Great White Pelicans on October 13th.

When considering records/h migration rates in the different weeks of the study period were low and varied between 0.1 and 0.5 records/h. Thus, no remarkable differences appeared when considering records/h as a measure for migratory activity.

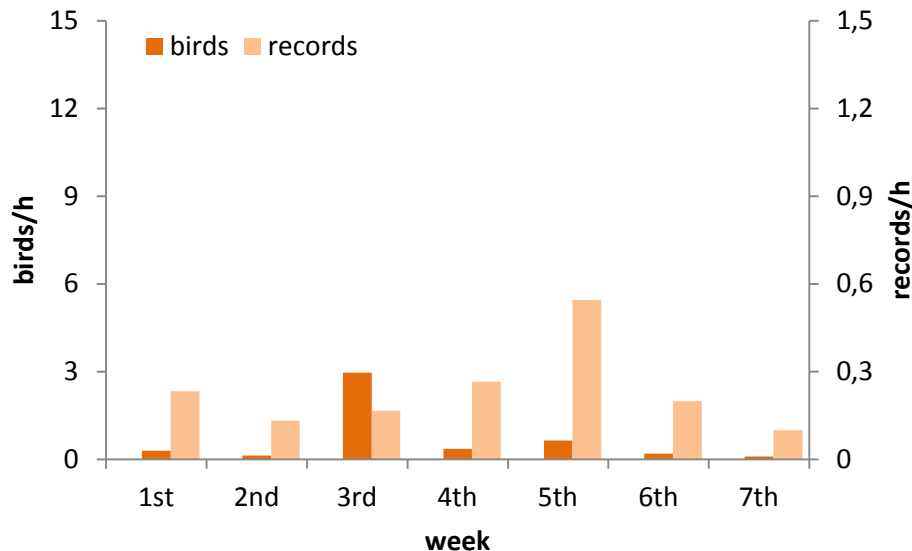

Figure 4.25: Migratory activity (birds/h and records/h) in different weeks of the study period (September 26th to November 8th) in autumn 2015 (only birds at distances of up to 2.5 km to the observation site; to correct different observational time the number of birds/records was divided by observational time of the particular week; 1st week: September 26th to October 1st)

Daily Distribution of Migratory Activity

Daily activity of large soaring birds was variable during the study period in autumn 2015. Considering the high standard deviation there were no remarkable differences in migration rates during the three periods of the day (morning, midday and afternoon, see Figure 4.26).

Most of the time migratory activity was very low: In more than half of all observation units no bird was recorded during each of the three periods and, hence, the median was equal to zero in every case.

Altitude of Migrating Birds

In autumn 2015 about 72 % of all birds and 33 % of all records were recorded at altitudes above 120 m (Table 4.10; however the value of this result is limited due to the low number of birds / records). 17 % of all birds and 41 % of all records were - at least temporary - registered at altitudes from 30 to 120 m (roughly representing the rotor swept area of wind turbines). Only few birds/records migrated exclusively at altitudes below 30 m.

Sooty Falcon, considered as “Near Threatened” (see above), were registered most times at altitudes below 30 m.

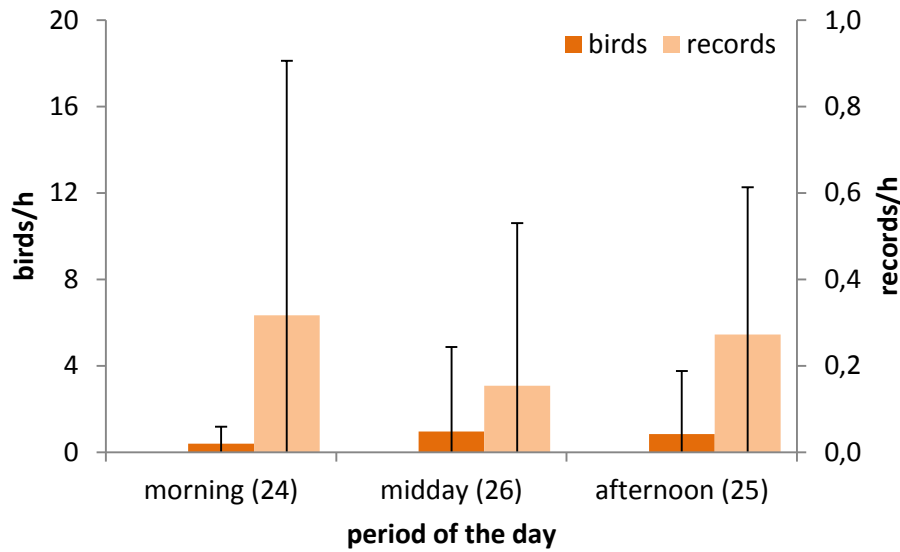

Figure 4.26: Average migratory activity (birds/h and records/h) at distances of up to 2.5 km to the observation site during different periods of the day in autumn 2015 (arithmetical mean and standard deviation; sample size (i.e. no. of observation days) for each period is given in brackets)

Table 4.10: Number of birds (above) and records (below) observed at distances of up to 2.5 km to the observation site at different flight altitude classes registered in autumn 2015

		flight altitude maximum (in m)		
		< 30 m	> 30 - 120 m	> 120 m
flight altitude minimum (in m)	birds			
	< 30 m	15	1	4
	> 30 - 120 m		7	11
> 120 m			100	
		flight altitude maximum (in m)		
		< 30 m	> 30 - 120 m	> 120 m
flight altitude minimum (in m)	records			
	< 30 m	12	1	3
	> 30 - 120 m		7	8
> 120 m			15	

Flight Directions

As usual during the migration period in autumn, the majority of birds (about 83 %) and records (about 54 %) migrated in southern directions. About 11 % of all birds and 30 % of all records headed for western directions.

Wind Speed and Wind Direction

In autumn 2016 medium wind from northern directions was dominant during most observation units (Figure 4.27).

Taken into account that soaring birds prefer migrating in tailwinds situations (e.g. Vansteelant et al. 2015) the conditions in the study area in autumn 2014 were (very) suitable during almost the entire study period. Nevertheless, the total number of migrating birds was comparably low. No remarkable relationship between migratory activity and prevailing wind conditions in the Alfanar area became apparent.

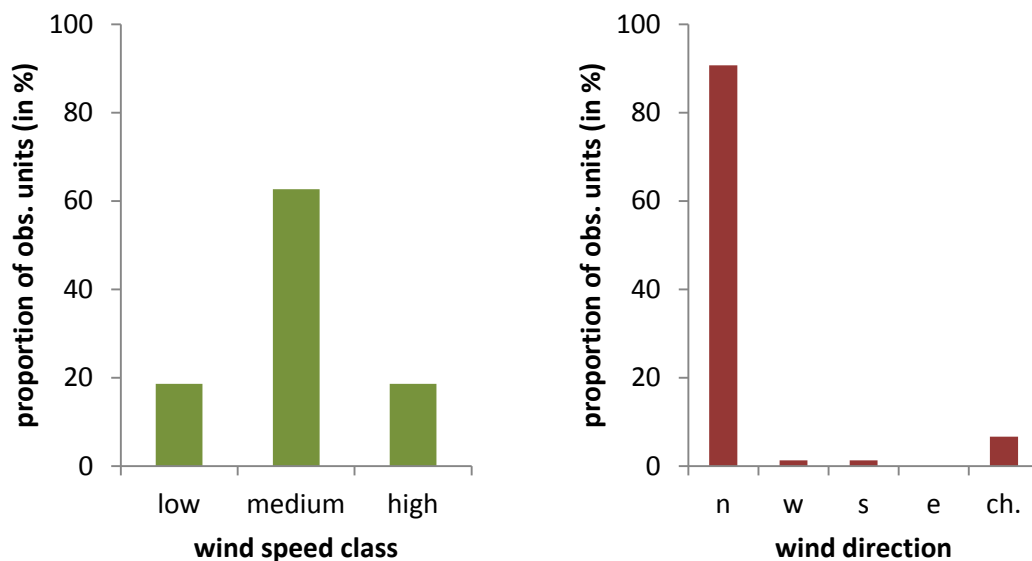

Figure 4.27: Wind speed (left) and wind direction (right) obtained in the Alfanar area in autumn 2015 (ch.= changing)

Other Observations of Migrating Birds

Migrating birds of species that are of minor relevance for the impact assessment were occasionally recorded during standardized observation units or by chance in the Alfanar area (see Table 4.11). No large soaring bird was recorded accidentally in the area in the study period in autumn 2015.

Table 4.11: Number of migrating birds of species that are of minor relevance for the impact assessment recorded in the Alfanar area in the study period in autumn 2015

species	scientific name	birds
Barn Swallow	<i>Hirundo rustica</i>	22
Common Chiffchaff	<i>Phylloscopus collybita</i>	1
White Wagtail	<i>Motacilla alba</i>	45
Red-Throated Pipit	<i>Anthus cervinus</i>	3
Water Pipit	<i>Anthus spinoletta</i>	1
Lark spec.	-	21
Pipit spec.	<i>Anthus spec.</i>	6

4.3.5.3.3 ACWA Area in Autumn 2015

Number of Migrating Birds, Species Composition and Flock Size

During standardized field observations in autumn 2015, lasting from August 24th to October 5th, a total of 6,213 birds from 18 relevant species were recorded at distances of up to 2.0 km to the two observation sites in the ACWA area (Table 4.12). In most cases single birds were registered (38 % of all records). Furthermore flocks of up to 10 individuals (about 30 %) and 11 to 100 individuals (about 30 %) were frequently registered. Flocks with more than 100 individuals were rarely observed (2 %).

According to the number of birds European Honey Buzzard, White Stork and Great White Pelican occurred most numerously. About 98 % of all registered birds belonged to one of these three species (Table 4.12). In contrast European Honey Buzzard, Marsh and Montagu's Harrier (together 83 % of all records) appeared most often in the ACWA area. In autumn 2015 Great White Pelican and White Stork rarely appeared (only three and four times, respectively) and, thus, the numbers were built up by single flocks, while European Honey Buzzard and Harriers frequently occurred.

Table 4.12: Number of birds and records registered in the ACWA area (i.e. at distances of up to 2.0 km from the observation sites) in the study period (August 24th to October 5th) in autumn 2015

species	scientific name	birds	records
Great White Pelican	<i>Pelecanus onocrotalus</i>	205	3
White Stork	<i>Ciconia ciconia</i>	1,011	4
Osprey	<i>Pandion haliaetus</i>	2	2
European Honey Buzzard	<i>Pernis apivorus</i>	4,851	290
Black Kite	<i>Milvus migrans</i>	18	13
Marsh Harrier	<i>Circus aeruginosus</i>	39	26
Pallid Harrier	<i>Circus macrourus</i>	5	5
Montagu's Harrier	<i>Circus pygargus</i>	32	26
Pallid / Montagu's Harrier	<i>Circus macrourus / pygargus</i>	8	8
Harrier	<i>Circus spec.</i>	2	2
Eurasian Sparrowhawk	<i>Accipiter nisus</i>	3	2
Steppe Buzzard	<i>Buteo buteo vulpinus</i>	6	2
Long-legged Buzzard	<i>Buteo rufinus</i>	3	3
Bonelli's Eagle	<i>Aquila fasciata</i>	1	1
Booted Eagle	<i>Aquila pennata</i>	1	1
Common Kestrel	<i>Falco tinnunculus</i>	4	4
Eleonora's Falcon	<i>Falco eleonora</i>	1	1
Sooty Falcon	<i>Falco concolor</i>	7	6
Eurasian Hobby	<i>Falco subbuteo</i>	1	1
Peregrine Falcon	<i>Falco peregrinus</i>	1	1
Falcon	<i>Falco spec.</i>	6	6
unidentified raptor	-	6	6
total		6,213	413

Classification due to IUCN Red List of Threatened Birds: "Near Threatened". Species listed as "Least Concern" or not considered in the IUCN Red List are not colored.

During autumn 2015 no species was recorded in the ACWA area that is considered as “Critically Endangered”, “Endangered” or “Vulnerable”. Two “Near Threatened” species were observed: Pallid Harrier and Sooty Falcon with a total of five and seven individuals, respectively (Note that there might have been further individuals of these or other species which might be found under Pallid / Montagu’s Harrier and Harrier, Falcon or unidentified raptor.).

Seasonal Distribution of Migratory Activity

In autumn 2015 migration rate (i.e. birds/h and records/h) steadily increased from the 1st to the 3rd week of the study period (Figure 4.28). Subsequently migratory activity was at a very low level from the 4th week up to the end of the survey.

More than 90 % of all registered birds passed the ACWA area during the first three weeks. In general the phenology was strongly affected by single days or rather single events. About 64 % of all birds and 46 % of all records were observed during five days: August 27th and 29th, September 1st, 2nd and 12th.

The obtained phenology was mainly caused by migrating European Honey Buzzards. Migration of this species peaked in the 3rd week, namely on September 12th when 1,793 individuals (96 records) were observed in the ACWA area. From the 5th week onwards migratory activity of European Honey Buzzards was very low.

The increase of migratory activity (birds/h) during the 2nd week was mainly caused by two larger flocks of White Stork (600 and 270 individuals), which were observed both on September, 1st.

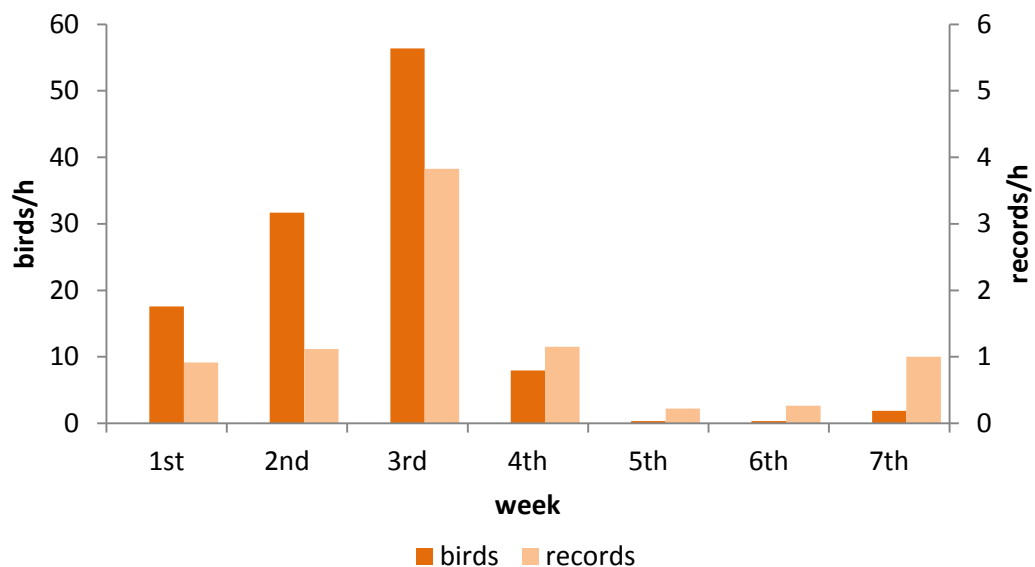

Figure 4.28: Migratory activity (birds/h and records/h) in different weeks of the study period (August 24th to October 5th) in autumn 2015 (only birds at distances of up to 2.0 km to the two observation sites; to correct different observational time the number of birds/records was divided by observational time of the particular week; 1st week: August 24th to 30th)

Daily Distribution of Migratory Activity

Due to highly variable (note the high standard deviation in Figure 4.29) migratory activity in the ACWA area, migration rates within different periods of the day did not significantly differ (Figure 4.29).

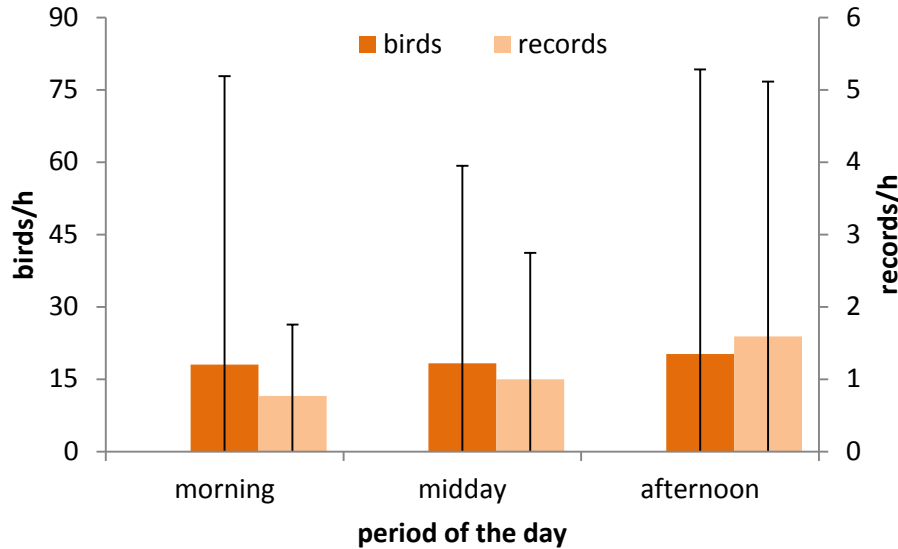

Figure 4.29: Average migratory activity (birds/h (full orange) and records/h (light orange), respectively) at distances of up to 2.0 km to the two observation sites during different periods of the day in autumn 2015 (arithmetical mean and standard deviation)

Altitude of Migrating Birds

In autumn 2015 about 24 % of all birds and 25 % of all records were observed at altitudes above 120 m (Table 4.13). About 74 % of all birds and 61 % of all records were - at least temporarily - registered at altitudes between > 30 and 120 m (roughly representing the rotor swept area of a wind turbine). Only few birds/records occurred at altitudes below 30 m.

Table 4.13: Number of birds (above) and records (below) observed at distances of up to 2.0 km to the observation sites at different flight altitude classes registered in autumn 2015

		flight altitude maximum (in m)		
		< 30 m	> 30 - 120 m	> 120 m
flight altitude minimum (in m)	birds			
	< 30 m	160	295	7
	> 30 - 120 m		3,205	1,074
> 120 m			1,472	
		flight altitude maximum (in m)		
		< 30 m	> 30 - 120 m	> 120 m
flight altitude minimum (in m)	records			
	< 30 m	58	9	3
	> 30 - 120 m		191	47
> 120 m			105	

The registered Pallid Harriers and Sooty Falcons (species listed as “Near Threatened”) mainly flew below 30 m.

Flight directions

As usual during the migration period in autumn, the majority of birds (about 94 %) migrated in southern directions (SSE, SSW) and a rather small fraction (about 6 %) in western directions (WSW, WNW).

Spatial Comparison of Migratory Activity

The average migration rate at observation site B was higher than at observation site A (for birds/h and records/h, see Figure 4.30). This result becomes even more obvious when comparing the total number of birds/records at the two observation sites (Table 4.14). European Honey Buzzard and White Stork, the most numerous species in the study area, were registered more often and in greater numbers at observation site B. However, it remains unclear whether this result was caused by the existence of preferred flight paths or simply by chance, i.e. by single flocks (e.g. three flocks of White Stork with a total of 1,010 individuals were recorded at site B, see Table 4.14).

According to the low migratory activity observed in autumn 2015 there are no apparent distinctive spatial patterns or special flight paths within the project area in autumn.

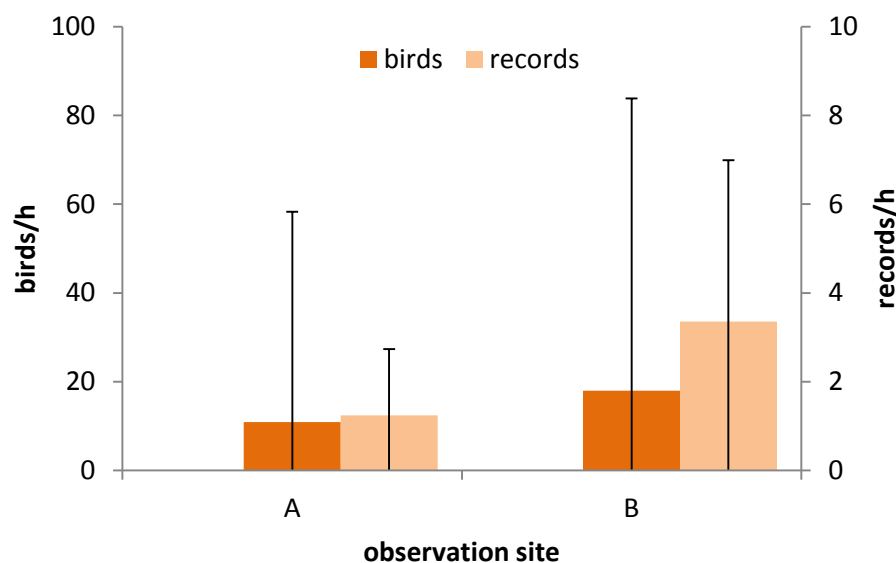

Figure 4.30: Comparison of migration rates at the two observation sites (A (n=154) and B (n=155)) in autumn 2015 (arithmetical mean and standard deviation over all observation units; sample size (i.e. no. of observation units) at each observation site is given in brackets)

Table 4.14: Number of birds and records registered at distances of up to 2.0 km to the observation sites A and B in the ACWA area in autumn 2015

species	scientific name	A		B	
		birds	records	birds	records
Great White Pelican	<i>Pelecanus onocrotalus</i>	75	1	130	2
White Stork	<i>Ciconia ciconia</i>	1	1	1,010	3
Osprey	<i>Pandion haliaetus</i>	.	.	2	2
European Honey Buzzard	<i>Pernis apivorus</i>	1,660	108	3,191	182
Black Kite	<i>Milvus migrans</i>	7	5	11	8
Marsh Harrier	<i>Circus aeruginosus</i>	12	9	27	17
Pallid Harrier	<i>Circus macrourus</i>	4	4	1	1
Montagu's Harrier	<i>Circus pygargus</i>	19	16	13	10
Pallid/Montagu's Harrier	<i>Circus macrourus/pygargus</i>	2	2	6	6
Harrier	<i>Circus spec.</i>	2	2	.	.
Eurasian Sparrowhawk	<i>Accipiter nisus</i>	.	.	3	2
Steppe Buzzard	<i>Buteo buteo vulpinus</i>	.	.	6	2
Long-legged Buzzard	<i>Buteo rufinus</i>	1	1	2	2
Bonelli's Eagle	<i>Aquila fasciata</i>	1	1	.	.
Booted Eagle	<i>Aquila pennata</i>	.	.	1	1
Common Kestrel	<i>Falco tinnunculus</i>	2	2	2	2
Eleonora's Falcon	<i>Falco eleonora</i>	1	1	.	.
Sooty Falcon	<i>Falco concolor</i>	6	5	1	1
Eurasian Hobby	<i>Falco subbuteo</i>	.	.	1	1
Peregrine Falcon	<i>Falco peregrinus</i>	.	.	1	1
Falcon	<i>Falco spec.</i>	2	2	4	4
unidentified raptor	-	2	2	4	4
sum		1,797	162	4,416	251

Wind Speed and Wind Direction

In autumn 2015 medium wind speed from northern directions was dominant (Figure 4.31).

Taken into account that soaring birds prefer migrating in tailwinds situations (e.g. Vansteelant et al. 2015) the conditions in the ACWA area in autumn 2015 were (very) suitable during almost the entire study period. Nevertheless, the total number of migrating birds was comparably low. There was no noticeable relationship between migratory activity and prevailing wind conditions in the ACWA area. Apparently, other factors than wind speed or wind direction affected migratory activity.

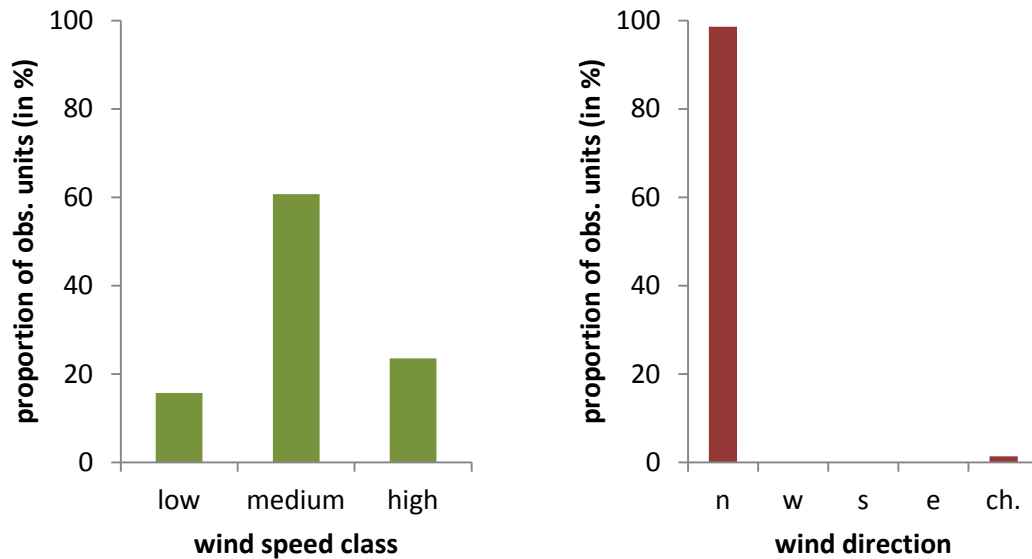

Figure 4.31: Wind speed (left) and wind direction (right) obtained in the ACWA area in autumn 2015 (ch.= changing)

Other Observations of Migrating Birds

While driving through the ACWA area only few observations of migrating and roosting birds were made in autumn 2015:

- European Honey Buzzard: 263 migrating individuals (6 records), two roosting individuals (1 record)
- Montagu's Harrier: 1 migrating individual
- Sooty Falcon: 1 foraging individual

4.3.5.3.4 Discussion and Assessment of the Importance of the Project Area for Autumn Migration Qualitative Assessment

It is firstly very important to point out that the investigation conducted in the project area in autumn 2016 did not fully cover main migration periods of large soaring species. As known from other surveys conducted at the Red Sea coast migratory activity in the autumn season is highest from mid / end of August to mid of September, i.e. during exactly those weeks which were missed by the current investigation. Thus, it is questionable whether the number of large soaring birds recorded during the study period is representative for autumn migration, because numbers of birds had probably already passed the area before the start of the investigation (e.g. White Stork, European Honey Buzzard or Great White Pelican).

This is even more valid for the investigation in the Alfanar area in autumn 2015.

Consequently, it is not possible to derive a complete picture of autumn migration and to assess the importance of the project area for large soaring birds based on these two data sets only. Furthermore, due to the late start of the investigation in the project area it is not possible to conduct a reliable species-specific extrapolation of the overall number of birds that likely migrated through the area during the migration season in autumn 2016.

Hence, conclusions for the autumn season have to be derived mainly from the survey undertaken in the ACWA area in autumn 2015. It is subsequently worth to check whether the data obtained in the project area in autumn 2016 is in accordance with the findings.

In the ACWA area a total of 413 records were registered during 348.3 hours of observation in autumn 2015 (i.e. 1.2 records/h) indicating a low migratory activity. The total number of birds (6,213) recorded in the ACWA area was low, too (As migratory activity was highly variable in space and time a species-specific extrapolation of the overall number of birds that likely migrated through the ACWA area in autumn 2015 would not lead to reasonable results (see Chapter 4.3.4.4.6)). Over vast periods of the autumn season migratory activity of relevant species was low. Remarkable migratory activity was restricted to single days and mainly referred to larger flocks that can be regarded as rare events. In fact, about 64 % of all birds and 46 % of all records were registered during only five days. Three species (European Honey Buzzard, White Stork and Great White Pelican) made up about 98 % of all recorded birds. None of these species is considered as to be threatened or near threatened (according to IUCN). To conclude, based on the results obtained in 2015 the ACWA area is not particularly important for autumn migration.

The data obtained in the project area in autumn 2016 and in the Alfanar area in autumn 2015 are very much in accordance with these findings and support the derived conclusion. Moreover, these conclusions are mainly in accordance with the general idea of autumn bird migration at the Red Sea:

- For several species bird migration in autumn is highest near Gabal el Zayt (i.e. between Ras Gemsa and Ras Shukeir), as most birds cross the Red Sea between El Tor and Gabal el Zayt (and probably further south up to Hurgada). Other large soaring species cross the Red Sea in the North, between Suez and Ain Soknah, and mainly follow the Red Sea Mountain chain further south. The mentioned areas are particularly important for large soaring birds (e.g. White Stork, Great White Pelicans and Eagles) in autumn.
- North of Ras Shukeir migratory activity is remarkably reduced leading to lower migration rates in areas near to and north of Ras Ghareb.

Based on these considerations the project area is not particularly important for large soaring birds in autumn.

Quantitative Assessment by Comparison of Migration Rates

A comparison of migration rates obtained in different areas at the Red Sea coast during the last years seems to be another useful way to assess the importance of the project area. However, it is worth mentioning that conclusions gained by such a comparison have to be treated carefully. As circumstances (year, area, observers, time of observation, climatic conditions etc.) differed and as migration rates were affected by single events (see above), a direct comparison is rarely possible. In addition, one has to consider that the survey conducted in autumn 2016 covered only a part of the migration season (as already discussed above). Nevertheless, a rough assessment of migratory activity can be achieved by a comparison of migration rates.

Average migration rate obtained in the project area in autumn 2016 was 2.6 birds/h and 0.3 records/h (see Table 4.15). This low migratory activity was definitely affected by the late start of the survey and cannot stand for usual migration in a full autumn season. This is even more valid for the average migration rate obtained in the Alfanar area (see Table 4.15).

A higher migration rate (17.8 birds/h) was recorded in the ACWA area in autumn 2015 (see Table 4.15). In the so-called 300 km² which is located (south)west of the project area bird migration was comparably low in autumn 2012 (5.5 birds/h). Based on these data one can expect to find an average migration rate between 5.0 and 20.0 birds/h in the project area. Remarkably higher autumn migration rates (47.3 and 86.5 birds/h, see Table 4.15) were recorded in areas further south, which are located near Gabel el Zayt. Considering that migration rate obtained in the ACWA area results from three common species (see above), one can conclude that the project area is not located in the main migration route of large soaring birds in autumn and is, thus, not of particular importance for target species during autumn migration.

Table 4.15: Migration rates recorded during autumn in different areas at the Red Sea coast (data from Bergen 2009, Bergen & Gaedicke 2013, ecoda 2007, 2011, 2016a, b)

location	year	migration rate birds/h	migration rate records/h
Ras Gemsa to Ras Shukeir	2007	86.5	2.4
Orange Zone (Gabel el Zayt)	2009	47.3	1.8
200 km ² area SW of Ras Ghareb	2010	21.9	0.7
300 km ² area NW of Ras Ghareb	2012	5.5	0.8
Alfanar area*	2015	0.7	0.3
ACWA area**	2015	17.8	1.2
project area*	2016	2.6	0.3

* - migration period not fully covered

** - only 2.0 km from observation sites (all other cases: 2.5 km)

Assessment by Criteria developed by BirdLife International

Commonly, the importance of a site is assessed by two criteria:

1. conservational status (IUCN Red List Category, see Annex I & II) of migrating target species; and
2. number of migrating birds/records of target species.

In this process, species that are exposed to a higher threat are of special interest. In the context of the autumn migration season such species are Steppe Eagle (Endangered) as well as Pallid Harrier, Red-footed Falcon and Sooty Falcon (Near Threatened) (Chapter 4.3.5.2.1).

Furthermore, species should be considered of which a significant proportion of the flyway population crosses the study area. Several criteria have been developed by BirdLife International for the selection of areas which are internationally important for birds. Within the scope of this investigation two criteria are particularly relevant:

1. An area where at least 20,000 storks, raptors or cranes regularly pass during spring or autumn migration is of international importance.
2. The second criterion is the abundance of each species in relation to the total flyway population. According to this, an area that regularly holds at least 1 % of a flyway population of a migratory species is of international importance, too. A flyway population is a population of a species sharing the same migration route linking breeding areas and wintering areas.

At the European (=regional) level, criteria have been applied to identify International Bird Areas (IBAs) for congregatory species and species of conservation concern. According to this, an area is a 'bottleneck' site where at least 5,000 storks (*Ciconiidae*) and/or at least 3,000 raptors (*Accipitriformes* and *Falconiformes*) and/or 3,000 cranes (*Gruidae*) regularly pass on spring or autumn migration.

Here, it is important to consider that the results obtained in the current monitoring present only a sample of the overall bird migration of target species in the project area. For several reasons, the real numbers of large soaring birds migrated through the project area in autumn 2016 have been, without any doubt, higher than the numbers obtained in this survey:

- a. The survey did not fully cover migration periods of large soaring species.
- b. Observations were restricted to six hours per day (per team), whereas the daily period mainly used for migration by target species birds from 1.5 hour after sunrise to 1.5 hour before sunset.
- c. Observations were conducted 6 days a week. Bird migration on the 7th day of the week was missed.
- d. Some migrating birds were probably missed during observations, especially birds migrating at higher altitudes (which are apparently of minor interest for the impact assessment, because these birds will not face the risk of colliding with a wind turbine).
- e. Due to the extent of the project area only parts of it could be monitored at the same time.

It might initially seem reasonable to correct the obtained data set for the mentioned factors and to calculate a real number of birds, e.g. by extrapolating the data applying correction factors that are based on certain assumptions. However, the explanatory power of such estimates is believed to be very weak (as given in Chapter 4.3.4.4.6).

During standardized field observations in autumn 2016 a total of 2,437 birds of target species were recorded at 14 sites within the project area (Table 4.5). In the ACWA area a total of 6,213 birds were recorded at two sites. Considering, that the obtained data represents only a sample of the overall migration (for the reasons mentioned above), it seems likely that the whole project area meets the 1st criterion developed by BirdLife International ("...at least 20,000 storks, raptors..."). However, it

should be highlighted that the project area is not a certain site that clearly differs from its surrounding. The project area forms a huge part of the coastal desert plains northwest of Ras Ghareb with a dimension of 284 km², i.e. a maximum length of 44 km (northwest to southeast) and a maximum width of about 10 km (west to east). Single FiT-plots (roughly corresponding to an area covering distances of up to 2.5 km to an observation site) are unlikely to meet this criterion. Hence, this criterion is always related to the size of a site: the larger an area, the higher the probability that the criterion is met.

About 0.35 % of the total flyway population of Great White Pelican was recorded in the whole project area in autumn 2016 (see Table 4.16). Taking into account that the real number of birds was likely higher (for the said reasons), the whole project area might also meet the 2nd criterion (1 % of a flyway population) developed by BirdLife International for this species. This is probably also valid for European Honey Buzzard, considering that 0.49 % of the total flyway population of this species was observed at the two observation sites in the ACWA area in autumn 2015 (see Table 4.16). In contrast, with regards to the obtained numbers of White Stork it seems unlikely that the 1 % criterion is met for this species. Again, it is important to point out that the 2nd criterion is related to the size of a site, too. So the size, the bordering and the surrounding of an area has to be considered, when assessing its importance for bird migration. To conclude, due to the huge size of the area, the 2nd criterion might be met for two common, non-threatened species: Great White Pelican and European Honey Buzzard. However, single FiT-plots (roughly corresponding to an area covering distances of up to 2.5 km to an observation site) are unlikely to meet this criterion. Thus, single FiT-plots are assessed not to be of particular importance for target species during autumn migration. This assessment seems to apply also to the whole project area, when considering that it does not differ from its surrounding, but forms a huge part of the coastal desert plains northwest of Ras Ghareb.

Table 4.16: Number of birds of the most numerous species recorded in the project area in autumn 2016 and in the ACWA area in autumn 2015, respectively, and according proportion (in %) of the flyway population

species	scientific name	number project area / ACWA	% of flyway pop. project area / ACWA
Great White Pelican	<i>Pelecanus onocrotalus</i>	244 / 205	0.35 / 0.29
White Stork	<i>Ciconia ciconia</i>	636 / 1,011	0.08-0.16 / 0.13-0.25
European Honey Buzzard	<i>Pernis apivorus</i>	1,335 / 4,851	0.13 / 0.49

Data on flyway population are taken from Lesham & Yom-Tov (1996), Hilgerloh (2009) and Carlbro (2009) after double-checking and comparison with other available sources. Due to the great difference between the size of the flyway population of the White Stork in Hilgerloh (2009) and Carlbro (2009) both proportions are given.

Due to the fact that the project area is not of particular importance for large soaring birds in autumn, no further discussion, e.g. on temporal or spatial distribution of migration, is necessary.

4.3.5.4 Results on Migrating Birds in Spring

4.3.5.4.1 Project Area in Spring 2016

Number of Migrating Birds, Species Composition and Flock Size

During the study period in spring 2016, i.e. from April 15th to May 25th, a total of 66,211 birds from 26 target species were observed at distances of up to 2.5 km from the 14 observation sites (Table 4.17). White Stork, European Honey Buzzard, Steppe Buzzard, Great White Pelican and Black Kite were the most numerous species. These five species represented 97 % of all registered individuals (Table 4.17). White Stork made up about 69 % of all registered birds and was, thus, by far the most numerous species.

A total of 1,510 records (of an individual or a flock) were registered at distances of up to 2.5 km from the observation sites. Steppe Buzzard (22 %), European Honey Buzzard (17 %) and Black Kite (13 %) were recorded most often.

Although large (> 1,000 individuals) or larger flocks (101 - 1,000 individuals) were rarely recorded, they had a strong effect on the dataset. In total there were eight flocks (0.5 % of all records) with more than 1,000 individuals and 93 flocks (6 % of all records) with 101 to 1,000 individuals, representing about 81 % of all migrating birds (Figure 4.32). In contrast, the fraction of birds migrating individually made up about 41 % of all records, yet about 1 % of all birds (Figure 4.32). Together, single birds and flocks with up to ten individuals comprised about 75 % of all records.

European Honey Buzzard, Steppe Buzzard and Black Kite occurred frequently (single or in small to medium sized flocks) and more or less numerous, while White Stork (and Great White Pelican) only appeared occasionally (mostly in large flocks with many individuals) (Figure 4.33).

During the study period four species of special interest within the impact assessment (due to their status on the IUCN Red List, see Chapter 4.3.5.2.1) were recorded in the study area: Egyptian Vulture, Grater Spotted Eagle, Steppe Eagle and Eastern Imperial Eagle (see Table 4.17). In addition the “Near Threatened” species Pallid Harrier and Sooty Falcon occurred in the study area in spring 2016.

Table 4.17: Number of birds and records registered in the study area (i.e. at distances of up to 2.5 km from the observation sites) in the study period (April 15th to May 25th) in spring 2016

species	scientific name	birds	records
Great White Pelican	<i>Pelecanus onocrotalus</i>	3,015	12
Black Stork	<i>Ciconia nigra</i>	192	25
White Stork	<i>Ciconia ciconia</i>	45,559	111
Osprey	<i>Pandion haliaetus</i>	11	7
European Honey Buzzard	<i>Pernis apivorus</i>	10,622	263
Black Kite	<i>Milvus migrans</i>	1,030	193
Egyptian Vulture	<i>Neophron percnopterus</i>	78	48
Short-toed Snake Eagle	<i>Circaetus gallicus</i>	100	71
Marsh Harrier	<i>Circus aeruginosus</i>	27	22
Pallid Harrier	<i>Circus macrourus</i>	4	4
Montagu's Harrier	<i>Circus pygargus</i>	4	4
Pallid / Montagu's Harrier	<i>Circus macrourus / pygargus</i>	3	3
Harrier	<i>Circus spec.</i>	1	1
Levant Sparrowhawk	<i>Accipiter brevipes</i>	413	18
Eurasian Sparrowhawk	<i>Accipiter nisus</i>	45	33
Sparrowhawk spec.	<i>Accipiter spec.</i>	2	2
Steppe Buzzard	<i>Buteo buteo vulpinus</i>	4,195	331
Long-legged Buzzard	<i>Buteo rufinus</i>	2	2
Buzzard	<i>Buteo spec.</i>	23	4
Lesser Spotted Eagle	<i>Aquila pomarina</i>	156	64
Greater Spotted Eagle	<i>Aquila clanga</i>	4	4
Steppe Eagle	<i>Aquila nipalensis</i>	249	118
Eastern Imperial Eagle	<i>Aquila heliaca</i>	7	6
Booted Eagle	<i>Aquila pennata</i>	81	72
Eagle	-	34	20
Lesser Kestrel	<i>Falco naumanni</i>	3	2
Common Kestrel	<i>Falco tinnunculus</i>	28	25
Lesser / Common Kestrel	<i>Falco naumanni / tinnunculus</i>	3	2
Eleonora's Falcon	<i>Falco eleonora</i>	3	3
Sooty Falcon	<i>Falco concolor</i>	3	3
Eurasian Hobby	<i>Falco subbuteo</i>	6	6
Lanner Falcon	<i>Falco biarmicus</i>	4	4
Falcon	<i>Falco spec.</i>	11	10
unidentified raptor	-	293	17
total		66,211	1,510

Classification due to IUCN Red List of Threatened Birds: "Endangered", "Vulnerable", "Near Threatened". Species listed as "Least Concern" or not considered in the IUCN Red List are not colored.

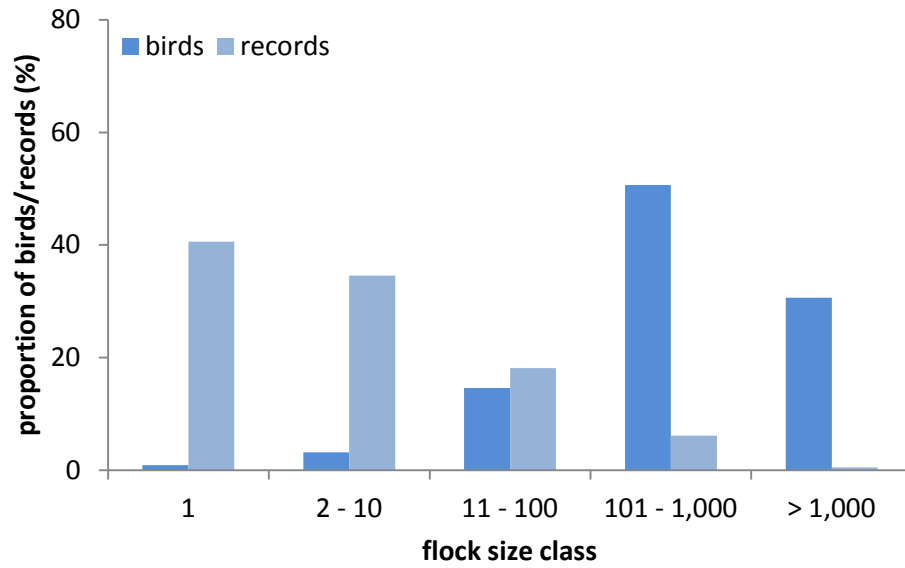

Figure 4.32: Relative abundance (proportion in %) of all birds/records registered at distances of up to 2.5 km in different flock size classes in the study period (April 15th to May 25th) in spring 2016

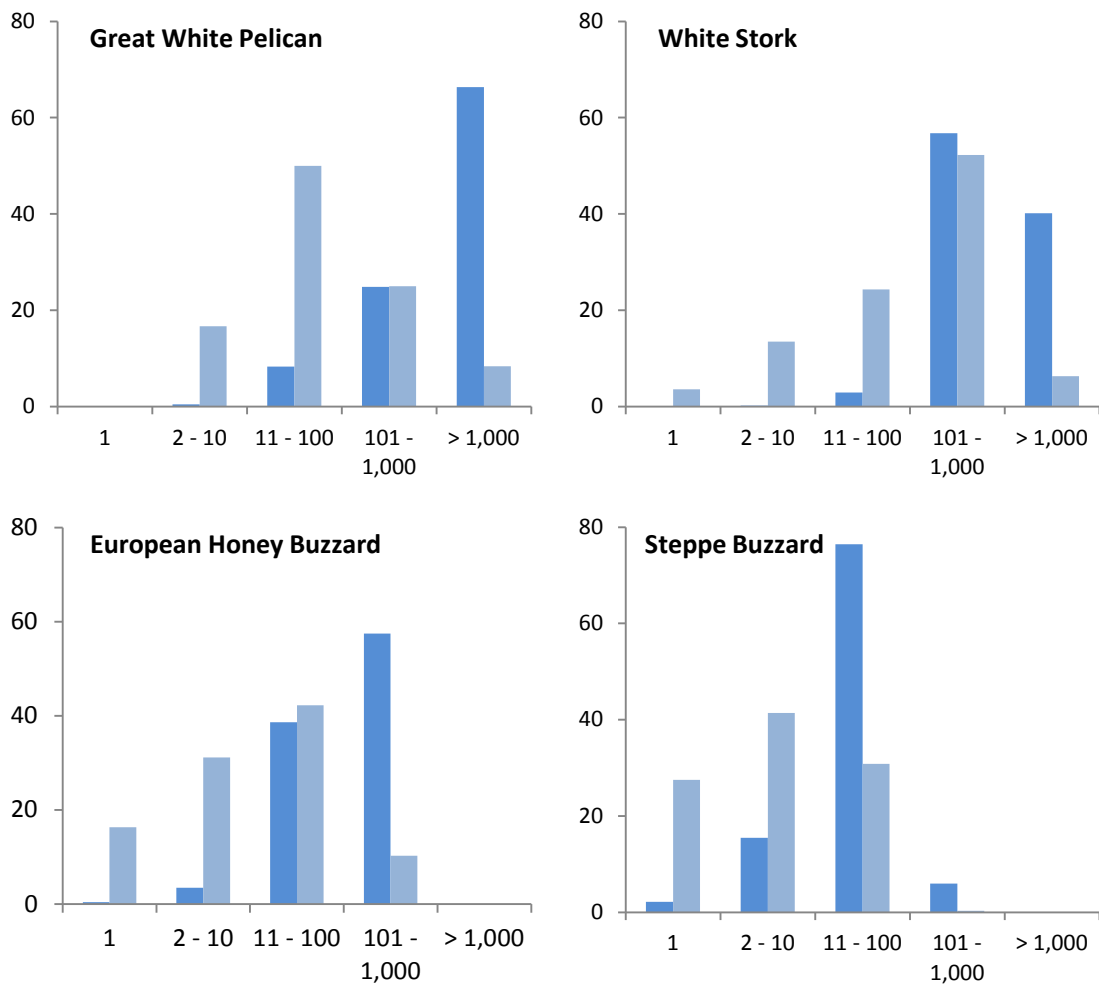

Figure 4.33: Relative abundance (proportion in %) of birds (blue) / records (light blue) of selected species registered at distances of up to 2.5 km in different flock size classes in the study period (April 15th to May 25th) in spring 2016

Seasonal Distribution of Migratory Activity

Migration rate (birds/h) was rather high in the first three weeks, decreased in the 4th week and was low in the last two weeks of the study period in spring 2016 (Figure 4.34). During the first three weeks, i.e. from April 15th to May 5th 80 % of all birds and 92 % of all records were registered. However, even during the first weeks migratory activity was highly variable. Migration was concentrated on only few days or brief periods. During only eight days (i.e. 23 % of all observation days) a total of 88 % of all birds appeared in the study area (see Table 4.18). During these eight days seven of eight flocks with more than 1,000 individuals and about 82 % of all flocks with 101 to 1,000 individuals were observed (see Table 4.18):

- On four days in late April few large flocks of White Stork, occasionally together with high numbers of European Honey Buzzard (50 % of all European Honey Buzzards were observed on April 26th) and Steppe Buzzard, lead to a high migratory activity.
- On four days in early May few large flocks of White Stork and occasionally Great White Pelicans and European Honey Buzzards lead to a high number of migrating birds.

The number of records was high on certain days, too, highly affecting the illustrated phenology. During only five days (about 14 % of all days) about 73 % of all records were registered.

Due to the late start of the survey (mid of April) main migration periods of single species were not fully covered. This is particularly valid for Common Crane which was not recorded in spring 2016, as the main migration period of this species lasts from end of February to mid of March. Moreover the number of Steppe Eagles, which is usually among the most numerous species at the western Red Sea coast in spring (e.g. Bergen & Gaedicke 2013, ecoda 2016a, 2016b), was rather low (main migration period: end of February to end of March). Thus, the number of Steppe Eagles recorded in spring 2016 was certainly not representative for spring migration. Even for other species (e.g. White Stork) numbers of birds might have already passed the project area before mid of April.

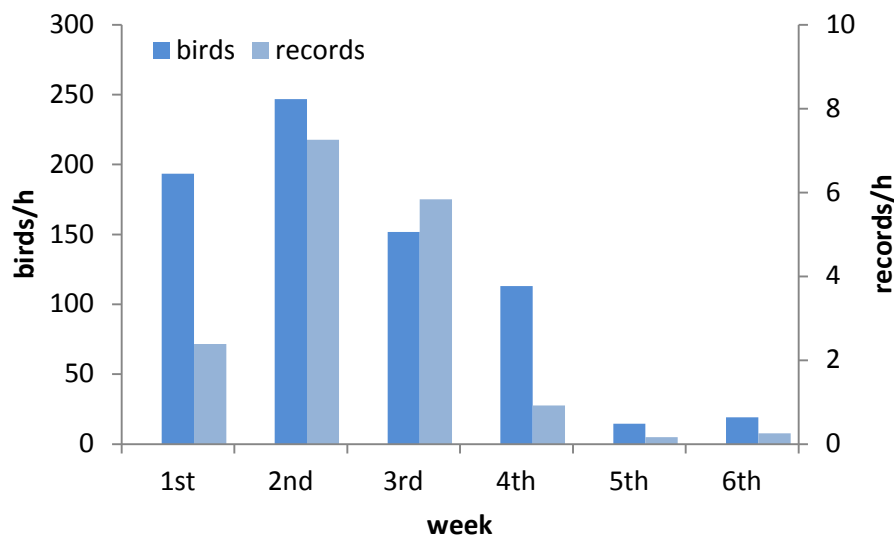

Figure 4.34: Migratory activity (birds/h and records/h) in different weeks of the study period (April 15th to May 25th) in spring 2016 (only birds at distances of up to 2.5 km to the observation sites; to correct different observational time the number of birds/records was divided by observational time of the particular week; 1st week: April 15th to 21st)

Table 4.18: Characteristics of migration on eight days with (very) high migratory activity in spring 2016

date	number of birds	share of birds (%)	remark
20.04.2016	11,518	17	11,050 White Storks (18 flocks: 3 with more than 1,000 and 15 with more than 100 individuals)
21.04.2016	4,376	7	4,252 White Storks (11 flocks: 9 with more than 100 individuals)
24.04.2016	8,936	14	5,428 White Storks (thereof a single flock of 4,000 individuals) 1,120 European Honey Buzzards (38 records) 1,274 Steppe Buzzards (84 records)
26.04.2016	12,215	18	5,272 European Honey Buzzards (50 % of the total number) 4,620 White Storks (7 flocks) 1,556 Steppe Buzzards
01.05.2016	6,847	10	2,901 White Storks (11 flocks) 2,185 Great White Pelicans (4 flocks: 1 flock with 2,000 birds)
02.05.2016	2,585	4	2,250 White (7 flocks)
03.05.2016	3,664	6	1,958 European Honey Buzzards (49 records) 1,028 White Storks (7 flocks)
08.05.2016	7,788	12	7,651 White Storks (4 flocks, thereof 1 flock with 4,000 individuals)
total	57,929	88	

Daily Distribution of Migratory Activity

Daily activity of large soaring birds was highly variable during the study period in spring 2016 (see Figure 4.35). Considering the high standard deviation there were no remarkable differences in migration rates during morning, midday and afternoon (though migration rate at 12 observation sites seemed to be slightly higher during midday and afternoon, whereas migration rates during morning-midday and midday-afternoon showed no difference at the two sites 6F and 8F; see Figure 4.35). Considering the median as a measure for daily distribution of migratory activity during the day it becomes apparent that most of the time migration was (very) low: During the morning the median was 0.7 birds/h (1st quartile: 0.0; 3rd quartile: 37.5 birds/h), during midday 9.0 birds/h (1st quartile: 0.0; 3rd quartile: 173.8 birds/h) and during afternoon 0.7 birds/h (1st quartile: 0.0; 3rd quartile: 54.8 birds/h) at the 12 sites, whereas it was nearly or equal to zero at sites 6F and 8F during morning-midday and midday-afternoon.

As mentioned above single events and/or single days had a strong effect on the data. For instance, on April 20th high migratory activity started at about 9:30 (i.e. 4.25 hours after sunrise) and lasted until the afternoon. The two observation units in the morning (at two of the 12 sites) were finished at 9:30 and 9:44, respectively. Hence, on this day migration rate was much higher during midday and afternoon than in the morning. In contrast, on April 26th migration rate was highest in the morning (the first large flock was recorded at 8:08) and decreased during the day.

To conclude, due to the high variability of bird migration over time and due to the huge effect of large flocks no daily pattern can be derived from the data obtained in spring 2016.

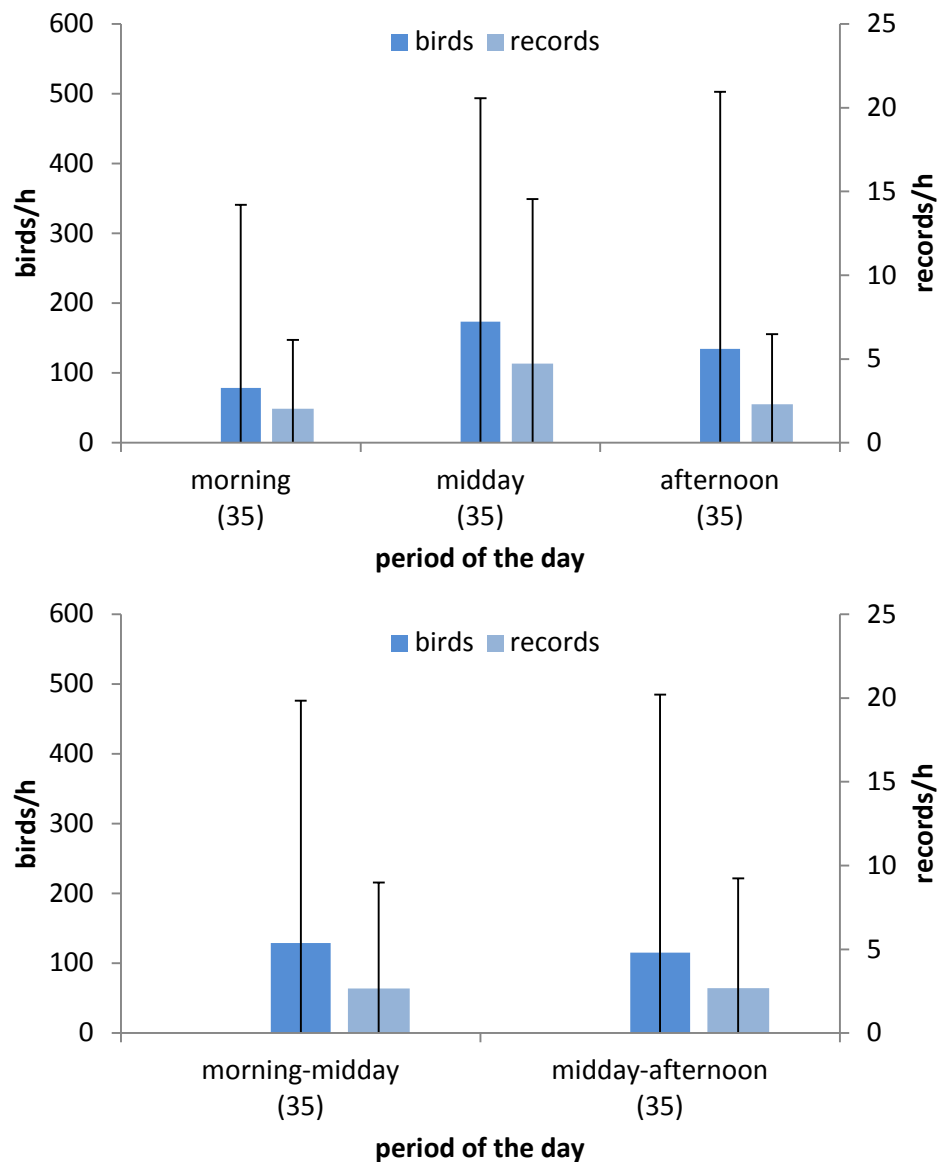

Figure 4.35: Average migratory activity (birds/h and records/h) at distances of up to 2.5 km to the observation sites during different periods of the day in spring 2016 (for sites 6F and 8F (below) and for all other 12 sites (above); arithmetical mean and standard deviation; sample size (i.e. no. of observation days) for each period is given in brackets)

Altitude of Migrating Birds

In spring 2016 about 62 % of all birds and 75 % of all records were recorded at altitudes above 120 m (Table 4.19). About 31 % of all birds and 19 % of all records were - at least temporary - registered at altitudes from 30 to 120 m (roughly representing the rotor swept area of wind turbines). Only few birds/records migrated exclusively at altitudes below 30 m. Species listed as “Endangered” of “Vulnerable” (according to the IUCN Red List) were mainly registered at altitudes above 120 m: Egyptian Vulture (85 %), Greater Spotted Eagle (100 %), Steppe Eagle (80 %) and Eastern Imperial Eagle (29 %)

Table 4.19: Number of birds (above) and records (below) observed at distances of up to 2.5 km to the observation sites at different flight altitude classes registered in spring 2016

flight altitude minimum (in m)	birds	flight altitude maximum (in m)		
		< 30 m	> 30 - 120 m	> 120 m
< 30 m		4,332	1,822	1,601
> 30 - 120 m			12,523	4,786
> 120 m				41,147

flight altitude minimum (in m)	records	flight altitude maximum (in m)		
		< 30 m	> 30 - 120 m	> 120 m
< 30 m		98	12	8
> 30 - 120 m			239	24
> 120 m				1,129

Flight Directions

As usual during the migration period in spring, the majority of birds (about 87 %) migrated in northern directions (88 % of all records). About 6 % headed for western and another 6 % of all birds for eastern directions.

Spatial Comparison of Migratory Activity

At first sight the spatial analysis suggests a higher average migration rate at observation sites 1, 4 and 7 (when considering birds/h) and at observation site 11 (when considering records/h) (see Figure 4.36). However, the large standard deviation clearly shows that the arithmetical mean is not a reliable measure to describe migratory activity at the 14 sites. It is apparent that the results were strongly affected by single events, namely large flocks of White Storks (see Map 4.5), leading to a high arithmetical mean at observation sites where such flocks were observed. But, these large flocks have to be regarded as rare events that can occur in the entire project area.

Considering the median it becomes apparent that most of the time migratory activity was (very) low (see Figure 4.37). At six of the 14 sites no bird was recorded in more than half of all observation units and, hence, the median was equal to zero. At 12 of the observation sites the median was less than 1.0 bird/h. Only at the sites 13 and 14 migrating soaring birds were recorded during most of the observation units leading to a comparably higher median of 17.3 and 9.3 birds/h, respectively (Figure 4.37) indicating a higher migration rate in the south of the project area.

When analysing migration rate at each observation site by simply dividing the number of birds by the observation time migratory activity was again highest at sites 1, 4 and 7 (Figure 4.38 and Map 4.4). As given before, this result was highly related with the number of large flocks (with more than 100 individuals). At sites 1, 4 and 7 the number of such flocks was obviously higher than at all other sites (Figure 4.38).

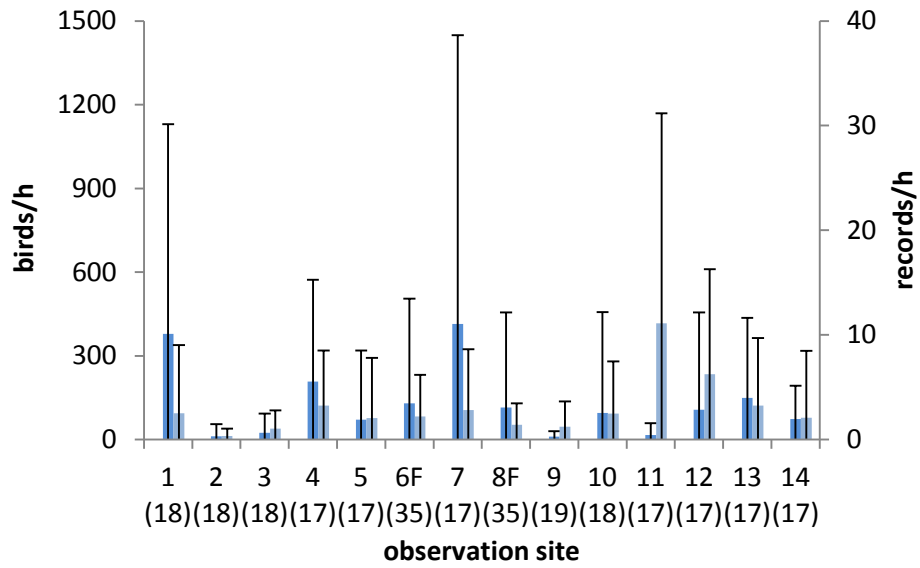

Figure 4.36: Comparison of migration rates (birds/h (blue) and records/h (light blue)) at the 14 observation sites in the study period (April 15th to May 25th) in spring 2016 (arithmetic mean and standard deviation over all observation units; sample size (i.e. no. of observation units) at each observation site is given in brackets)

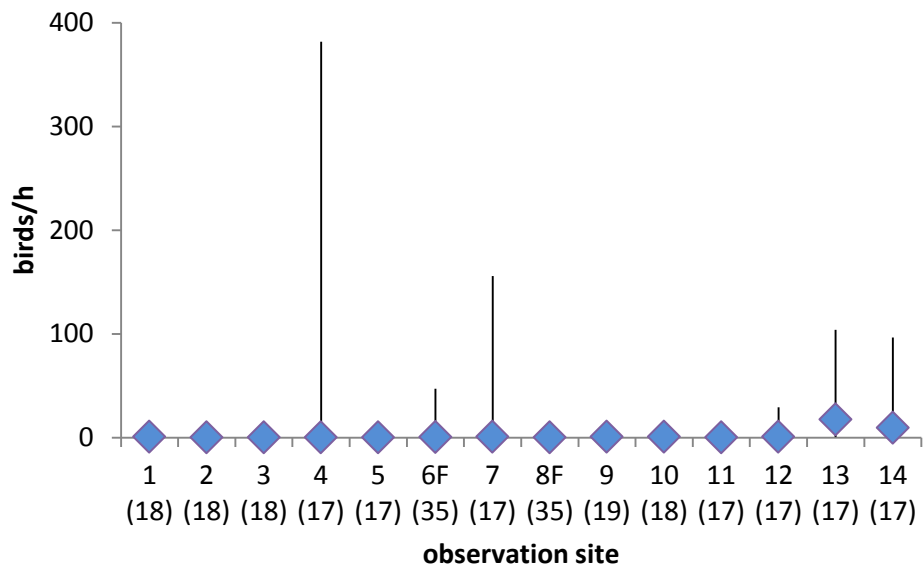

Figure 4.37: Comparison of migration rates (birds/h (blue) and records/h (light blue)) at the 14 observation sites in the study period (April 15th to May 25th) in spring 2016 (median, 1st and 3rd quartile over all observation units; sample size (i.e. no. of observation units) at each observation site is given in brackets)

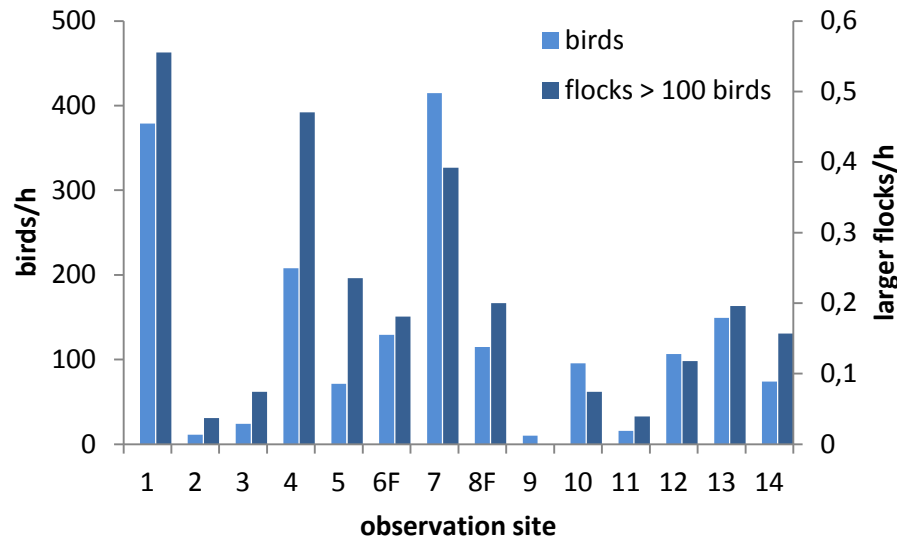

Figure 4.38: Migration rate (birds/h) and larger flocks (with > 100 birds)/h at the 14 observation sites

As given above, migratory activity significantly varied between different days (about 88 % of all birds were observed on only eight days). Bearing this in mind, the results on the spatial distribution of migratory activity were highly affected by the site-specific number of observation units that were conducted on these eight days. The obtained high migration rates at sites 4 and 7 (Figure 4.36 and 4.34) and at sites 13 and 14 (Figure 4.37) can partly be explained by this effect, as observations were conducted at these sites at six of the eight days (see Table 4.20). However, this effect cannot account for the high migration rate at site 1, where observations were carried out on only two of the eight days.

No significant difference in migration rates (birds/h and records/h) during synchronous observation units at two sites was detected by application of Wilcoxon signed-rank test (Table 4.21).

Table 4.20: Number of observation units (no. obs. units) per site conducted on the eight days with the highest migratory activity (aggregating about 88 % of all recorded birds, see Table 3.18)

site	1	2	3	4	5	6F	7	8F	9	10	11	12	13	14
no. obs. units	2	2	2	6	6	8	6	8	2	2	2	6	6	6

Table 4.21: Comparing migration rate (birds/h and records/h) at observation sites during synchronous observation units (results of Wilcoxon signed-rank test for paired samples: significant difference would exist, if $p < 0.05$)

pair of obs. sites	birds/h		records/h	
	V	p	V	p
1 / 9	12.0	0.281	10.0	0.588
2 / 10	3.0	0.581	0.0	0.098
3 / 11	1.0	1.000	1.0	1.000
4 / 12	10.5	0.498	8.5	0.269
5 / 13	7.0	0.272	2.0	0.050
7 / 14	24.0	0.906	14.0	0.343

Map 4.4
Mean migration rate of target species (birds/h) obtained by different surveys in spring 2016

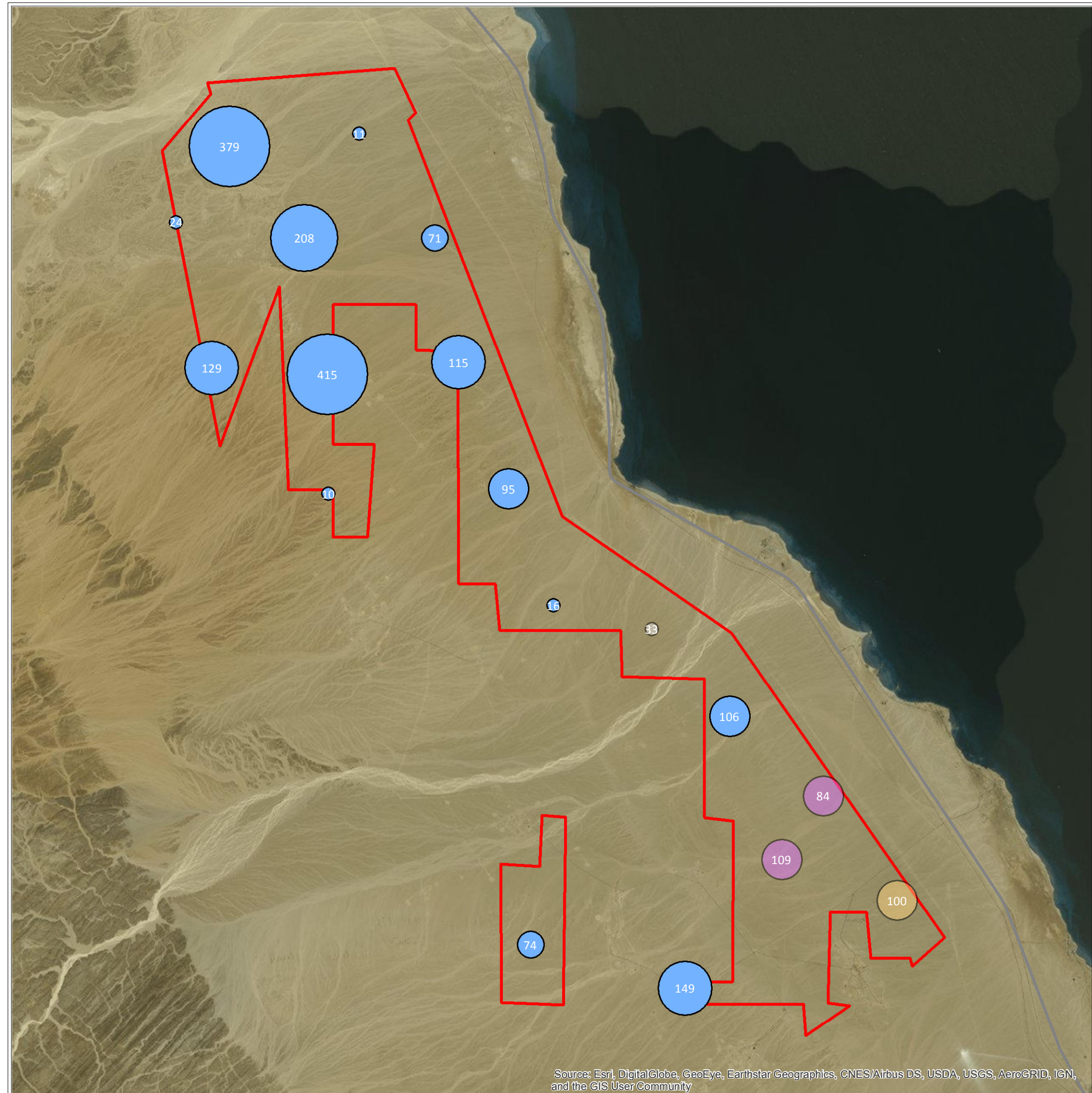

Project Area

boundaries of the project area

existing roads

Overall Migration Rate (geometric interval)

- < 50.0 birds / hour
- 50.0 to 74.9 birds / hour
- 75.0 to 114.9 birds / hour
- 115.0 to 174.9 birds / hour
- 175.0 to 269.9 birds / hour
- > 269.9 birds / hour

Surveys

- RCREEE survey
- Alfanar survey
- ACWA survey
- Lekela survey

● editor: Lars Gaedicke, July 31st 2017

0 10 km

1:150.000



Map 4.5
Flight paths of Great White Pelican and White Stork during the study period in spring 2016

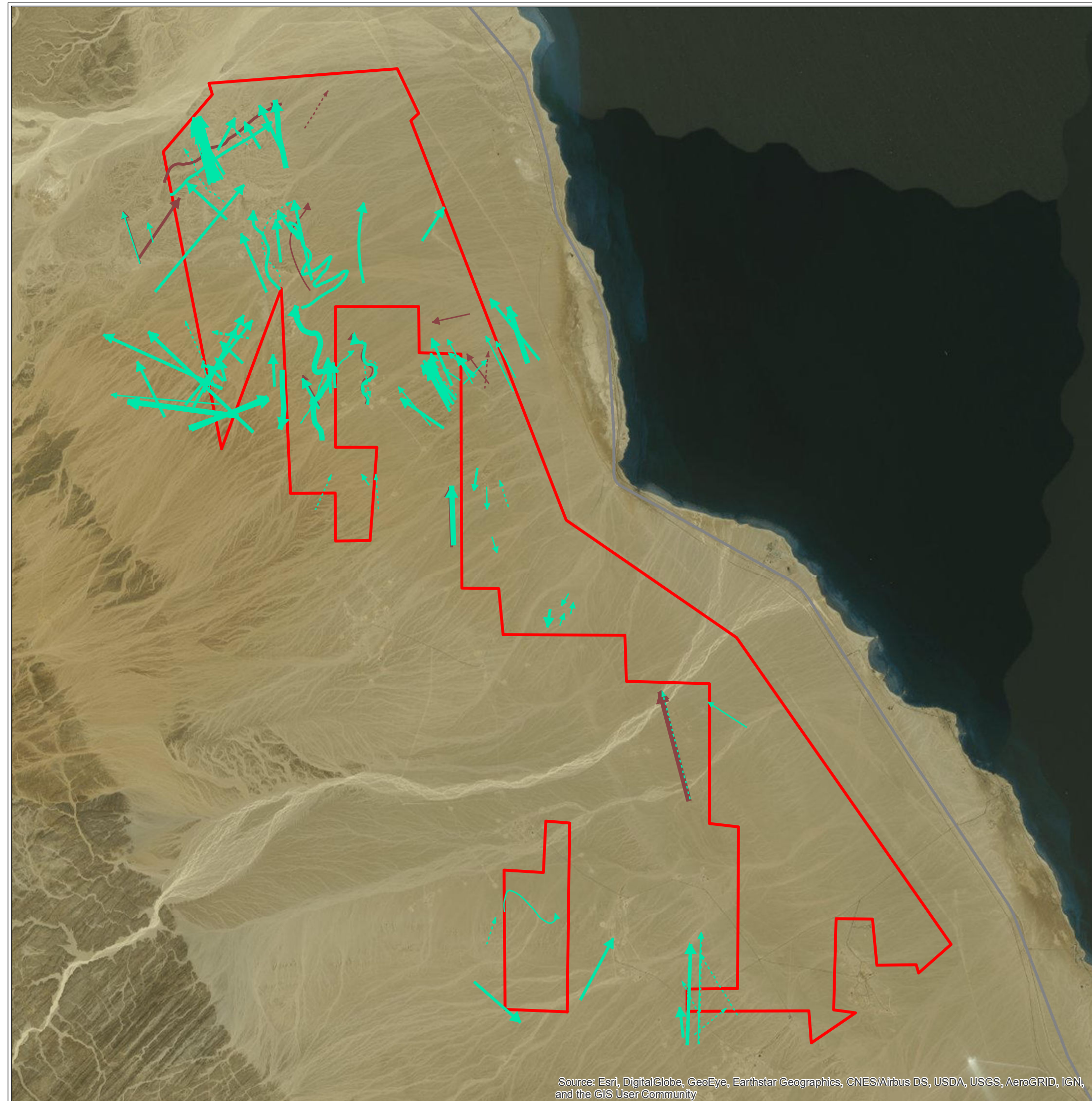

Project Area

- boundaries of the project area
- existing roads

Flight Paths of

- Great White Pelican
- White Stork

Number of Birds

- - - - - → 1 to 10 individuals
- — — — — → 11 to 100 individuals
- = = = = = → 101 to 1,000 individuals
- ▬ ▬ ▬ ▬ ▬ → 1,001 to 2,000 individuals

● editor: Lars Gaedicke, July 31st 2017

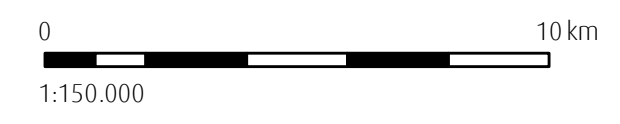

Summing up, the obtained spatial differences in migratory activity at the 14 observation sites are not caused by the existence of preferred flight paths or by avoidance of certain areas and, thus, do not reflect actual spatial differences in bird migration. The different migration rates refer to few large flocks which were rare events and which were recorded on single days only. Though the terrain is rising to the west and though the project area is somewhat hilly in its northern part, there are no remarkable topographic features which affect the spatial distribution of large soaring birds in spring. To conclude, no spatial differentiation can be made when describing and assessing migratory activity in the project area in spring.

Wind Speed and Wind Direction

In spring 2016 medium and high wind speed from northern directions was dominant during standardized observations of migrating birds (Figure 4.39).

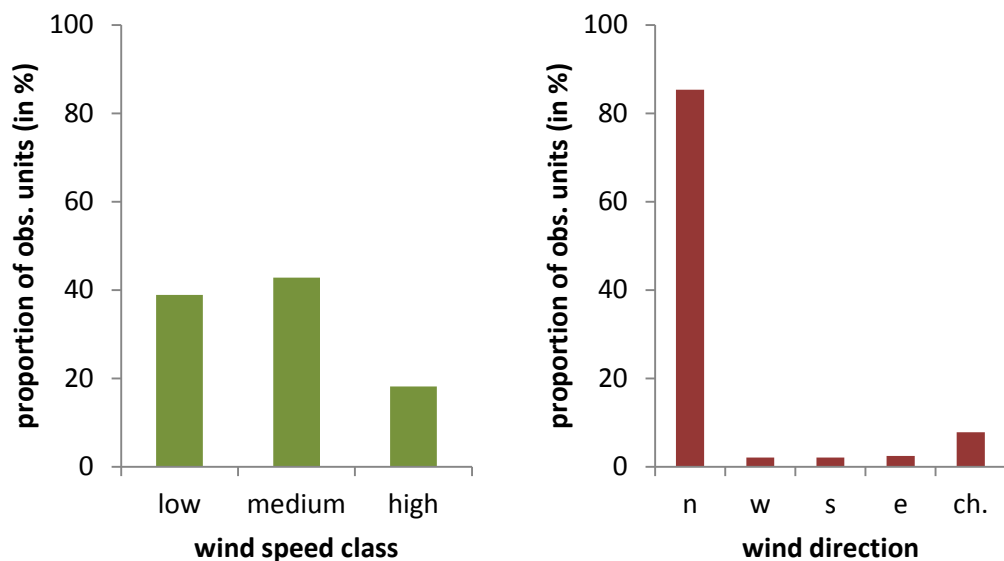

Figure 4.39: Wind speed (left) and wind direction (right) obtained in the study area in spring 2016 (ch.= changing)

Large soaring birds migrate most effectively with tailwind (e.g. Vansteelant *et al.* 2015) and should avoid situations with strong headwind. At the Red Sea coast, however, the wind usually comes from northern directions in spring (see for instance Figure 4.39) and, thus, migrating birds mostly find situations with headwinds, i.e. unfavourable conditions.

In fact, the majority of birds and records were registered in situations with wind from northern directions in spring 2016 (Figure 4.40). Lower numbers were found in situations with southern wind direction and with changing wind conditions.

On the background of general migrating behaviour the following three assumptions can be drawn with regards to the relationship between wind regime and bird migration:

1. A high migratory activity can be expected in favourable conditions with (strong) southern wind. If so, the proportion of birds/records in such situations should have been higher in spring 2016 than the proportion of observation units with this wind regime. In addition high migration rates can be expected

In fact, the relative abundance of migrating birds and of records was disproportionately higher during observation units with southern wind than could be expected (Figure 4.41). In addition,

bird migration rate was highest during southern wind of low speed (Figure 4.42). Even in situations with strong wind coming from southern directions a remarkable migration rate was obtained (but note that observational time was only 3 hours), whereas migratory activity was extremely low during strong winds coming from northern directions (though observational time was 91.5 hours; see Figure 4.42).

Nevertheless, these findings are difficult to interpret, because

- i. wind from southern directions very rarely occurred (only for 12 hours of observation (i.e. about 2 % of the total observational time);
- ii. the high number of birds recorded in these conditions referred mainly to three observation days with a very high migratory activity (April, 24th and 26th and May 1st, see Table 4.18); and
- iii. the high number of birds were strongly affected by few large flocks of Great White Pelican and White Stork (see Table 4.18).

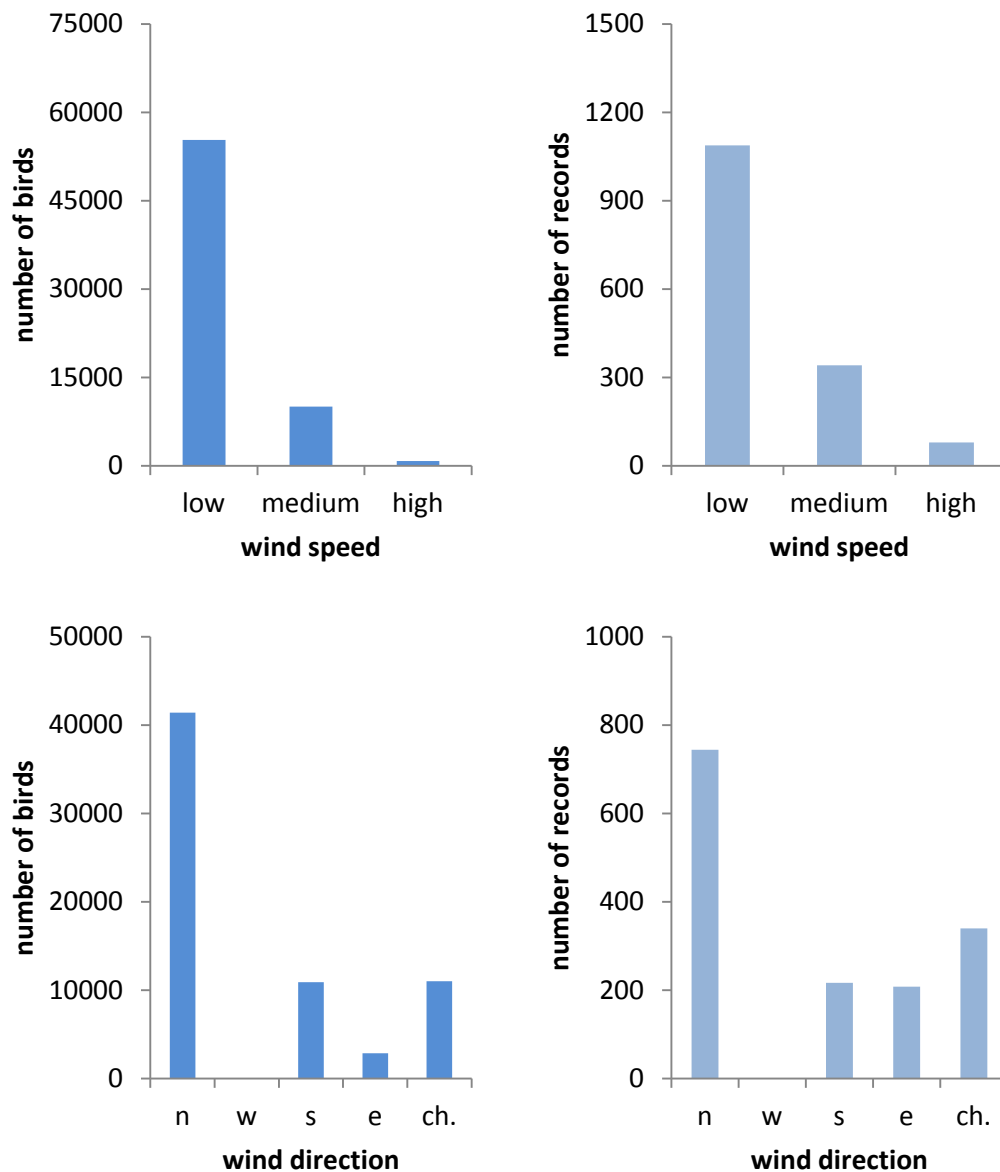

Figure 4.40: Total numbers of birds (left) and records (right) registered in the study area during certain wind speed (above) and wind direction (below) conditions in spring 2016

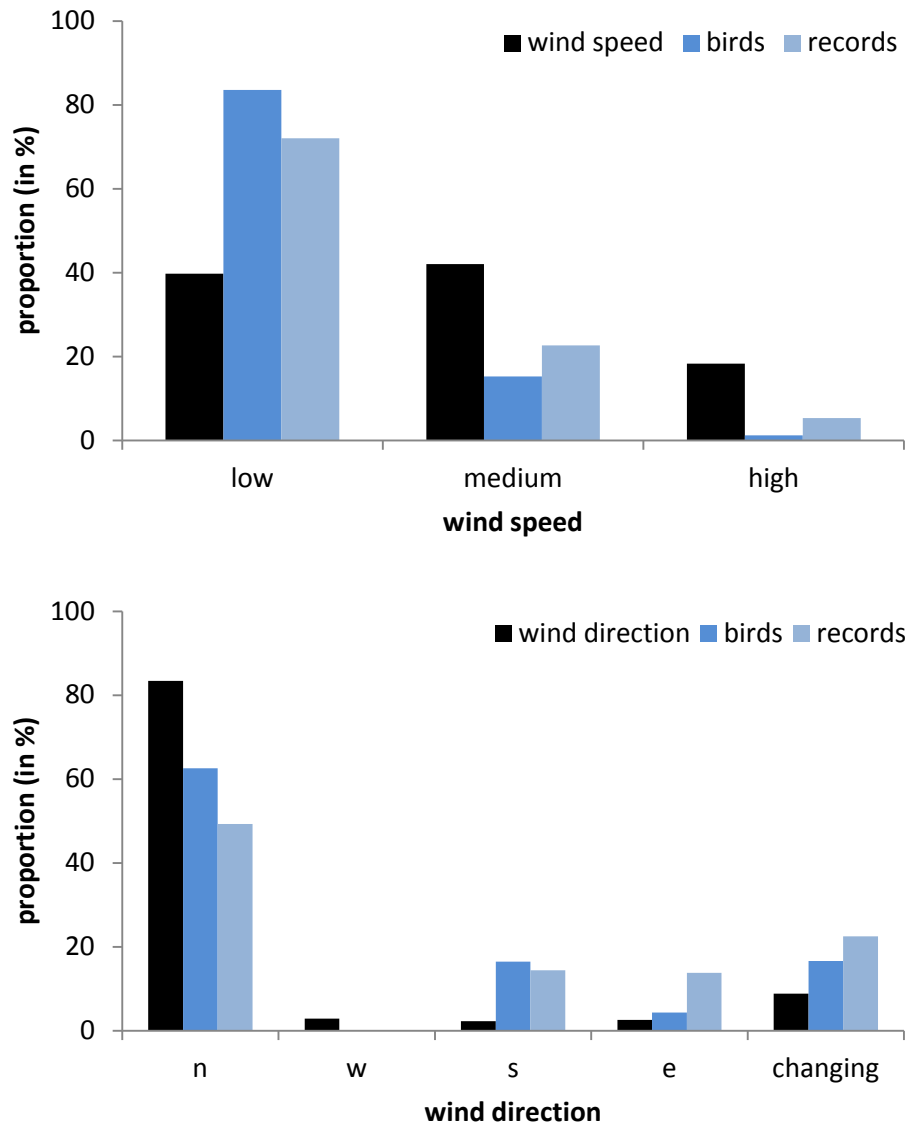

Figure 4.41: Proportion of observational time (n=525 hours) during different wind speed (above) and wind direction (below) conditions and relative abundance (in %) of birds (n=66,212) and records (n=1,510) registered during the according wind conditions in spring 2016

To conclude, it is most likely that high migratory activity on the mentioned days was at least partly triggered by the favourable wind regime. Thus, the above mentioned assumption, that wind from southern directions can favour bird migration and can cause an increase in migratory activity in the study area, could be partly verified. However, it must not be neglected that the majority of birds occurred during a northern wind regime. Hence, bird migration is most probably not only influenced by wind direction and wind speed, but also by other external factors (e.g. season). For example, southern winds might have only a small effect at the end of the overall migration period when migration of a number of species, in particular the most frequent species (White Stork and Great White Pelican), is already completed.

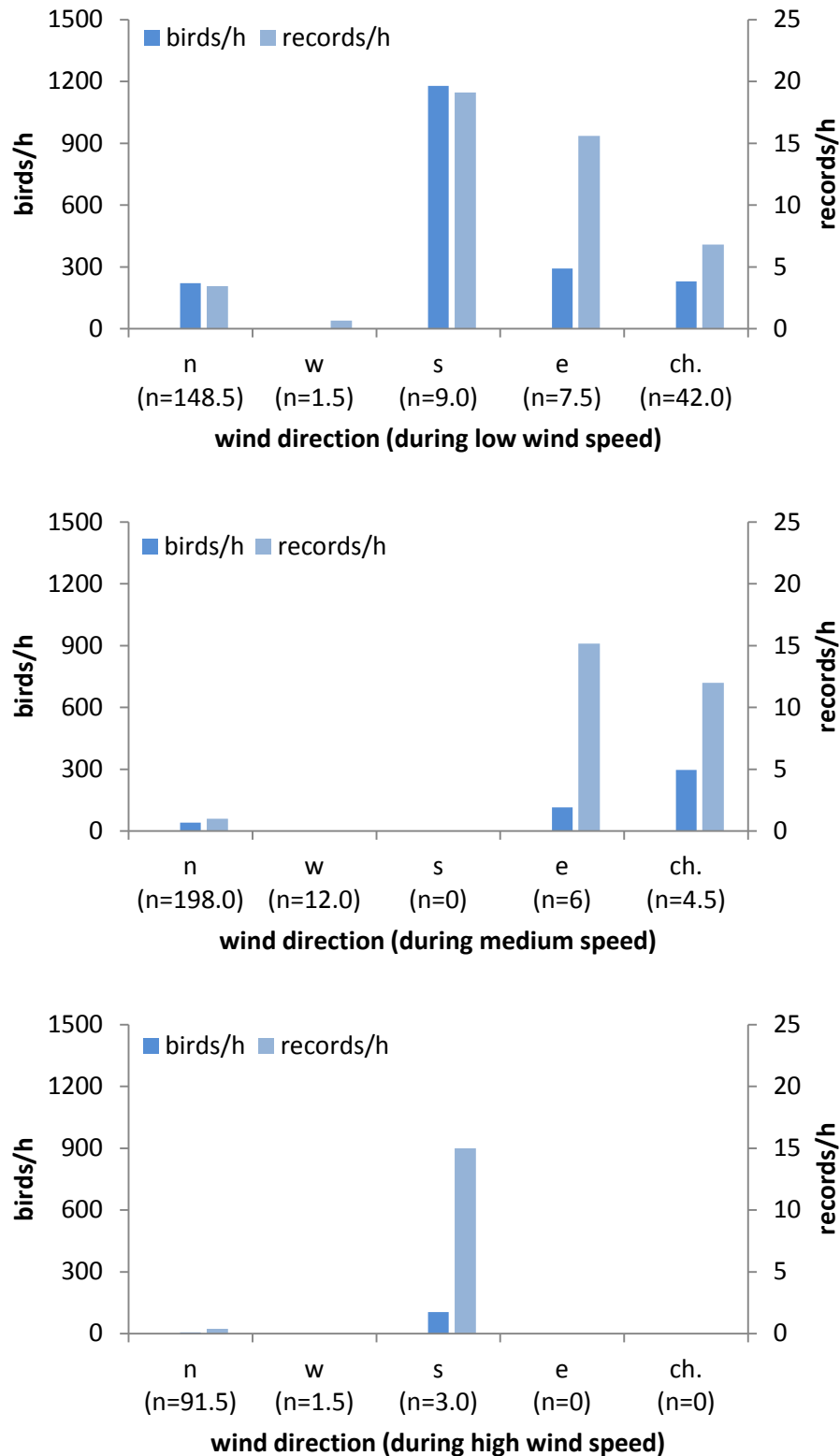

Figure 4.42: Migration rates (birds/h and records/h) obtained during different prevailing wind regimes (low (above), medium (middle) and high (below) wind speeds in spring 2016; the observational time for each wind regime is given in brackets)

2. Situation with low wind speed (even if it is headwind), changing wind or with lateral wind (i.e. from western or eastern direction) should have a small effect (neither adverse nor beneficial) on migratory activity. As a consequence, an average to high migratory activity could be expected and the proportion of birds/records should be in accordance with the proportion of observational time during the according wind regime.

The vast majority of birds migrated during low wind situations (Figure 4.40) and the proportion of birds and records was higher than the proportion of the according observation time (Figure 4.41). This is - though to a lower degree - also valid for changing wind directions. These results indicate that in a region with prevailing northern winds birds use low wind speed conditions for migration.

3. The final assumption is that migratory activity should be low in unfavourable conditions with medium to strong northern wind.

In fact, the number of birds/records was very low in situations with high wind speeds (Figure 3.36) and the relative abundance of birds and records was clearly lower than could be expected, both for high and medium wind speed (Figure 4.41). Migration rates in situations with northern winds of medium and high speeds, which together covered about 55% of the overall observational time, was very low (Figure 4.42). Thus, this assumption was verified by the results gained in spring 2016.

To conclude, the analysis revealed that spring migration in the study area might be higher in favourable situations (with wind from southern directions (that rarely occur) or with low wind speeds) and lower in unfavourable conditions (with medium to strong wind from northern directions). However, as northern wind is predominant at the western coast of the Red Sea and as birds need to reach the breeding territories in time (as early as possible), birds are forced to migrate even during unfavourable conditions. To restrict migration to only favourable conditions cannot be an appropriate ecological strategy, because such situations rarely occur at the Red Sea coast in spring. In addition, migratory activity is not only affected by the wind regime, but by other internal and external factors. Hence, the wind regime alone can hardly be used as a simple predictor for the extent of migratory activity on certain a day.

Other Observations of Migrating Birds

Migrating birds of species that are of minor relevance for the impact assessment were occasionally recorded during standardized observation units or accidentally in the project area (see Table 4.22). No large soaring bird was recorded accidentally in the project area in spring 2016.

Table 4.22: Number of migrating birds of species that are of minor relevance for the impact assessment recorded in the project area in spring 2016

species	scientific name	no. of birds
Little Bittern	<i>Ixobrychus minutus</i>	1
Whiskered Tern	<i>Chlidonias hybridus</i>	5
European Turtle Dove	<i>Streptopelia turtur</i>	1
Common Swift	<i>Apus apus</i>	13
European Bee-eater	<i>Merops apiaster</i>	47
Sand Martin	<i>Riparia riparia</i>	4
Barn Swallow	<i>Hirundo rustica</i>	219
Common House Martin	<i>Delichon urbica</i>	23
Lesser Whitethroat	<i>Sylvia curruca</i>	1
Yellow Wagtail	<i>Motacilla flava spec.</i>	1
Red-throated Pipit	<i>Anthus cervinus</i>	1

4.3.5.4.2 Project Area in Spring 2017

Number of Migrating Birds, Species Composition and Flock Size

During the study period in spring 2017, i.e. from February 20th to May 20th, a total of 147,611 birds from 27 target species were observed at distances of up to 2.5 km from the 14 observation sites (Table 4.23). White Stork, Steppe Buzzard and European Honey Buzzard were the most numerous species. These three species represented 90 % of all registered individuals (Table 4.23). White Stork made up about 63 % of all registered birds and was, thus, by far the most numerous species.

A total of 3,601 records (of an individual or a flock) were registered at distances of up to 2.5 km from the observation sites. Steppe Buzzard (27 %), Steppe Eagle (23 %), Black Kite (11 %), European Honey Buzzard (8 %) and Short-toed Snake Eagle (8 %) were recorded most often.

Although large (> 1,000 individuals) or larger flocks (101 - 1,000 individuals) were rarely recorded, they had a strong effect on the dataset. In total there were 23 flocks (0.6 % of all records) with more than 1,000 individuals and 157 flocks (4 % of all records) with 101 to 1,000 individuals, together representing about 83 % of all migrating birds (Figure 4.43). In contrast, the fraction of birds migrating individually made up about 40 % of all records, yet about 1 % of all birds (Figure 4.43). Together, single birds and flocks with up to ten individuals comprised about 79 % of all records.

Great White Pelican and in particular White Stork appeared mainly in larger flocks with up to 1,000 or even more than 1,000 individuals (Figure 4.44). European Honey Buzzard, Black Kite and Steppe Buzzard were mostly recorded in medium sized (1 to 100 individuals) to larger flocks (101 to 1,000 individuals). Steppe Eagle occurred frequently (single or in small to medium sized flocks).

During the study period four species of special interest within the impact assessment (due to their status on the IUCN Red List, see Chapter 4.3.5.2.1) were recorded in the study area: Egyptian Vulture, Grater Spotted Eagle, Steppe Eagle and Eastern Imperial Eagle (see Table 4.23). In addition the “Near Threatened” species Pallid Harrier and Sooty Falcon occurred in the study area in spring 2017.

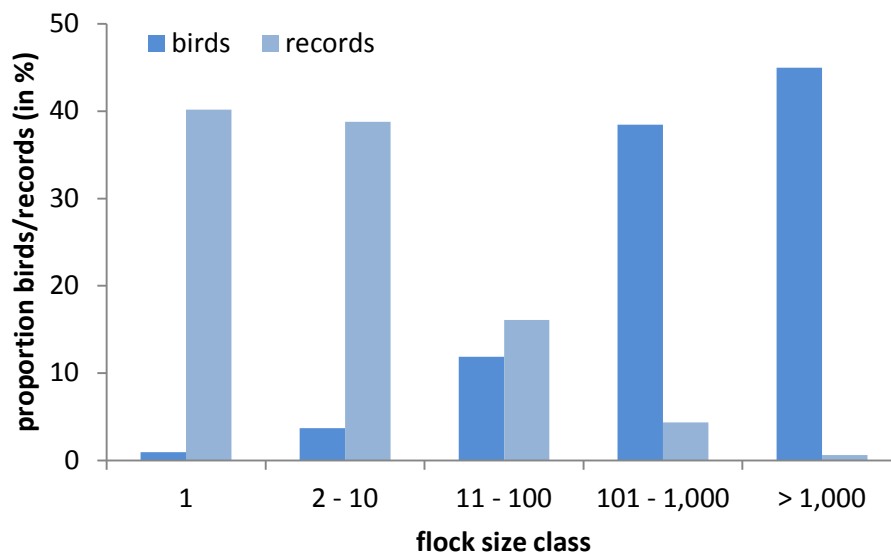

Figure 4.43: Relative abundance (proportion in %) of all birds/records registered at distances of up to 2.5 km in different flock size classes in the study period in spring 2017

Table 4.23: Number of birds and records registered in the study area (i.e. at distances of up to 2.5 km from the observation sites) in the study period (February 20th to May 20th) in spring 2017

species	scientific name	birds	records
Great White Pelican	<i>Pelecanus onocrotalus</i>	770	8
Black Stork	<i>Ciconia nigra</i>	249	41
White Stork	<i>Ciconia ciconia</i>	93,199	150
Osprey	<i>Pandion haliaetus</i>	20	18
European Honey Buzzard	<i>Pernis apivorus</i>	7,531	306
Black Kite	<i>Milvus migrans</i>	4,077	402
Egyptian Vulture	<i>Neophron percnopterus</i>	56	44
Short-toed Snake Eagle	<i>Circaetus gallicus</i>	472	302
Marsh Harrier	<i>Circus aeruginosus</i>	36	30
Pallid Harrier	<i>Circus macrourus</i>	10	10
Montagu's Harrier	<i>Circus pygargus</i>	42	32
Pallid / Montagu's Harrier	<i>Circus macrourus / pygargus</i>	4	4
Harrier	<i>Circus spec.</i>	3	3
Levant Sparrowhawk	<i>Accipiter brevipes</i>	822	14
Eurasian Sparrowhawk	<i>Accipiter nisus</i>	14	12
Sparrowhawk spec.	<i>Accipiter spec.</i>	5	2
Steppe Buzzard	<i>Buteo buteo vulpinus</i>	32,516	990
Long-legged Buzzard	<i>Buteo rufinus</i>	26	26
Buzzard	<i>Buteo spec.</i>	308	36
Lesser Spotted Eagle	<i>Aquila pomarina</i>	72	42
Greater Spotted Eagle	<i>Aquila clanga</i>	10	6
Steppe Eagle	<i>Aquila nipalensis</i>	4,740	844
Eastern Imperial Eagle	<i>Aquila heliaca</i>	19	17
Booted Eagle	<i>Aquila pennata</i>	153	97
Eagle	-	52	17
Lesser Kestrel	<i>Falco naumanni</i>	1	1
Common Kestrel	<i>Falco tinnunculus</i>	99	75
Eleonora's Falcon	<i>Falco eleonora</i>	1	1
Sooty Falcon	<i>Falco concolor</i>	1	1
Lanner Falcon	<i>Falco biarmicus</i>	2	2
Barbary Falcon	<i>Falco pelegrinoides</i>	1	1
Falcon	<i>Falco spec.</i>	6	6
unidentified raptor	-	463	51
Common Crane	<i>Grus grus</i>	1,831	10
total		147,611	3,601

Classification due to IUCN Red List of Threatened Birds: "Endangered", "Vulnerable", "Near Threatened". Species listed as "Least Concern" or not considered in the IUCN Red List are not colored.

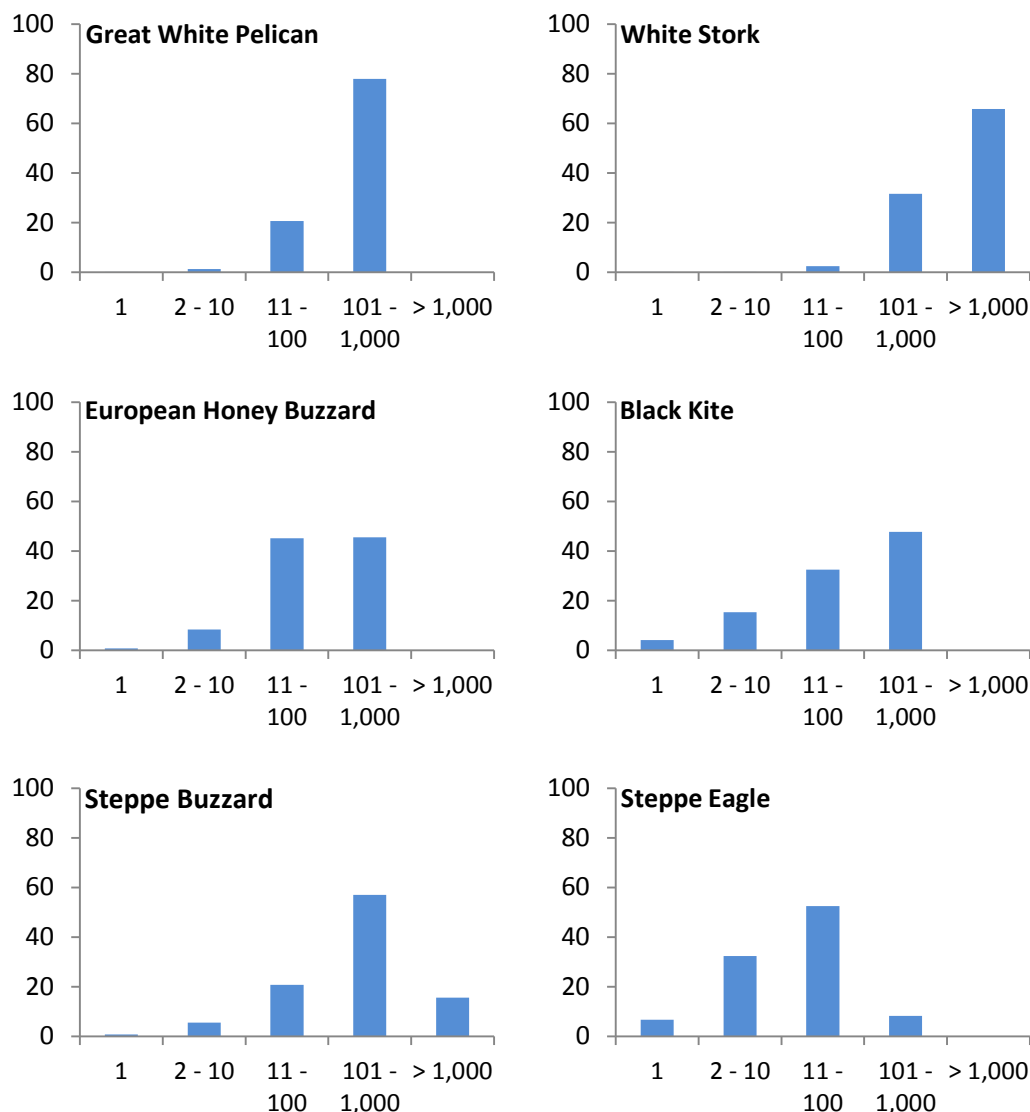

Figure 4.44: Relative abundance (proportion in %) of birds (blue) / records (light blue) of selected species registered at distances of up to 2.5 km in different flock size classes in spring 2017

Seasonal Distribution of Migratory Activity

Migration rate (birds/h) was rather low during the first four weeks, decreased in the 5th and 6th week (i.e. mid to end of March) and was highly variable up to mid of May (Figure 4.45) – with peaks in the 8th and 11th week of the study period covering 30 % and 25 % of all birds, respectively.

Migration was concentrated on only few days or brief periods. During only ten days (i.e. 14 % of all observation days) a total of 76 % of all birds appeared in the study area (see Table 4.24). During these ten days 18 of 23 flocks with more than 1,000 individuals and about 55 % of all flocks with 101 to 1,000 individuals were observed (see Table 4.24):

- On two single days in the second half of March few large flocks of White Stork, occasionally together with high numbers of Steppe Buzzard, lead to a high migratory activity.
- On four days during an eight day-period in mid of April few large flocks of White Stork and high numbers of Black Kite, Steppe Buzzard and Steppe Eagle lead to a high number of migrating birds.

- The high migratory activity on three single days end of April and early to mid of May again referred to White Stork and, in addition, to European Honey Buzzard.

The number of records was high on these ten days, too (39 % of all records).

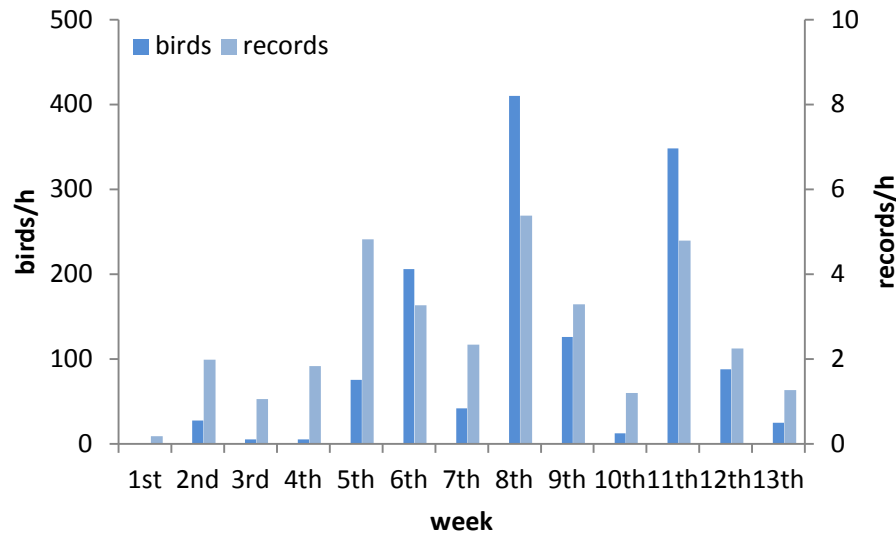

Figure 4.45: Migratory activity (birds/h and records/h) in different weeks in spring 2017 (only birds at distances of up to 2.5 km to the observation sites; to correct different observational time the number of birds/records was divided by observational time of the particular week; 1st week: February 20th to 22nd)

Table 4.24: Characteristics of migration on ten days with (very) high migratory activity in spring 2017

date	number of birds	share of birds (%)	remark
23.03.2017	5,671	17	1,813 White Storks (4 flocks) 3,099 Steppe Buzzards
30.03.2017	16,358	7	16,300 White Storks (4 flocks)
11.04.2017	9,362	14	9,200 White Storks (3 flocks)
12.04.2017	13,486	18	2,408 White Storks (10 flocks), 502 Black Kites 9,546 Steppe Buzzards, 735 Steppe Eagles
13.04.2017	20,921	10	5,900 White Storks (8 flocks), 1,554 Black Kites 12,826 Steppe Buzzards, 565 Steppe Eagles
15.04.2017	6,209	4	6,000 White Storks (1 flock)
18.04.2017	5,208	6	4,223 White Storks (13 flocks), 310 Black Kites 470 Steppe Buzzards, 88 Steppe Eagles
29.04.2017	18,172	12	17,939 White Storks (12 flocks)
01.05.2017	12,749	12	9,911 White Storks (30 flocks) 2,000 European Honey Buzzards
10.05.2017	4,093	12	574 White Storks (8 flocks) 3,314 European Honey Buzzards
total	112,229	76	

Daily Distribution of Migratory Activity

Daily activity of large soaring birds was highly variable during the study period in spring 2017 (see Figure 4.46). Considering the high standard deviation there were no remarkable differences in migration rates during morning, midday and afternoon (though migration rates (birds/h) seemed to be slightly higher during morning).

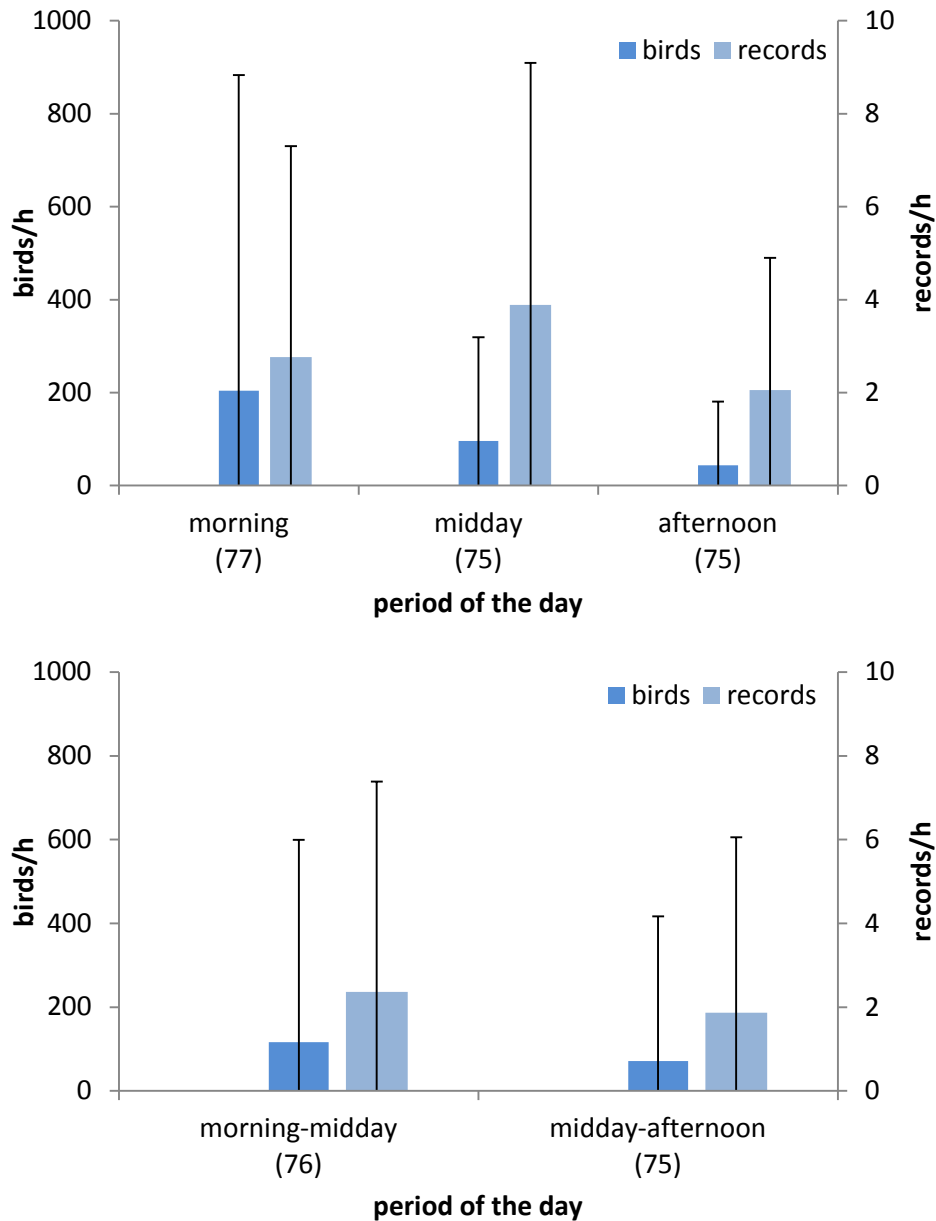

Figure 4.46: Average migratory activity (birds/h and records/h) at distances of up to 2.5 km to the observation sites during different periods of the day in spring 2016 (for sites 6F and 8F (below) and for all other 12 sites (above); arithmetical mean and standard deviation; sample size (i.e. no. of observation days) for each period is given in brackets)

Considering the median as a measure for daily distribution of migratory activity during the day it becomes apparent that most of the time migration was low: During the morning the median was 1.3 birds/h (1st quartile: 0.3; 3rd quartile: 3.5 birds/h), during midday 0.5 birds/h (1st quartile: 0.3; 3rd quartile: 5.0 birds/h) and during afternoon 0.3 birds/h (1st quartile: 0.0; 3rd quartile: 1.8 birds/h) at the 12 sites and at 6F and 8F during morning-midday 0.3 birds/h (1st quartile: 0.0; 3rd quartile: 2.1 birds/h) and during midday-afternoon 0.0 birds/h (1st quartile: 0.0; 3rd quartile: 1.0 birds/h). As mentioned above single events and/or single days had a strong effect on the data.

To conclude, due to the high variability of bird migration over time and due to the huge effect of large flocks no daily pattern can be derived from the data obtained in spring 2017.

Altitude of Migrating Birds

In spring 2017 about 59 % of all birds and 58 % of all records were recorded at altitudes above 120 m (Table 4.25). About 41 % of all birds and 38 % of all records were - at least temporary - registered at altitudes from 30 to 120 m (roughly representing the rotor swept area of wind turbines). Only few birds/records migrated exclusively at altitudes below 30 m. A relevant portion of birds from species listed as “Endangered” or “Vulnerable” (according to the IUCN Red List) were registered - at least temporary - at altitudes from 30 to 120 m: Egyptian Vulture (32 %), Greater Spotted Eagle (30 %), Steppe Eagle (21 %) and Eastern Imperial Eagle (21 %).

Table 4.25: Number of birds (above) and records (below) observed at distances of up to 2.5 km to the observation sites at different flight altitude classes registered in spring 2017

		flight altitude maximum (in m)		
		< 30 m	> 30 - 120 m	> 120 m
flight altitude minimum (in m)	birds			
	< 30 m	845	4,579	8,060
	> 30 - 120 m		22,234	25,068
> 120 m			86,825	
		flight altitude maximum (in m)		
		< 30 m	> 30 - 120 m	> 120 m
flight altitude minimum (in m)	records			
	< 30 m	136	126	48
	> 30 - 120 m		871	325
> 120 m			2,095	

Flight Directions

As usual during the migration period in spring, the majority of birds (about 93 %) migrated in northern directions (90 % of all records). About 5 % headed for western and another 2 % of all birds for eastern directions.

Spatial Comparison of Migratory Activity

Migration rates at the 14 observation sites were highly variable over the study period and no remarkable difference between sites appeared (Figure 4.47). The large standard deviation clearly shows that the arithmetical mean is a weak measure to describe migratory activity at the 14 sites. It is apparent that the results were strongly affected by single events, namely large flocks of White Storks (see Maps 4.7 and 4.8), leading to a high arithmetical mean at sites where such flocks were observed. But, these large flocks have to be regarded as rare events that can occur in the entire project area.

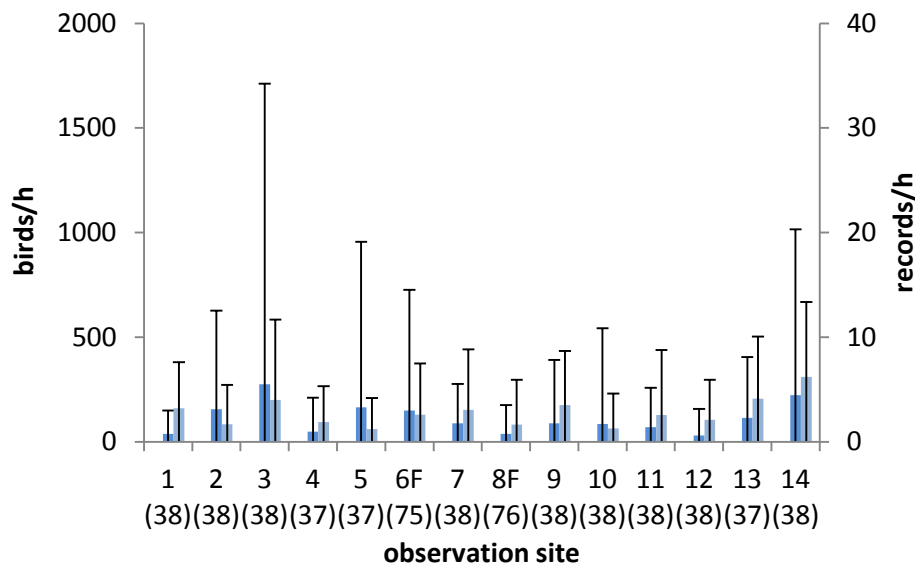

Figure 4.47: Comparison of migration rates (birds/h (blue) and records/h (light blue)) at the 14 observation sites in spring 2017 (arithmetical mean and standard deviation over all observation units; sample size (i.e. no. of observation units) at each observation site is given in brackets)

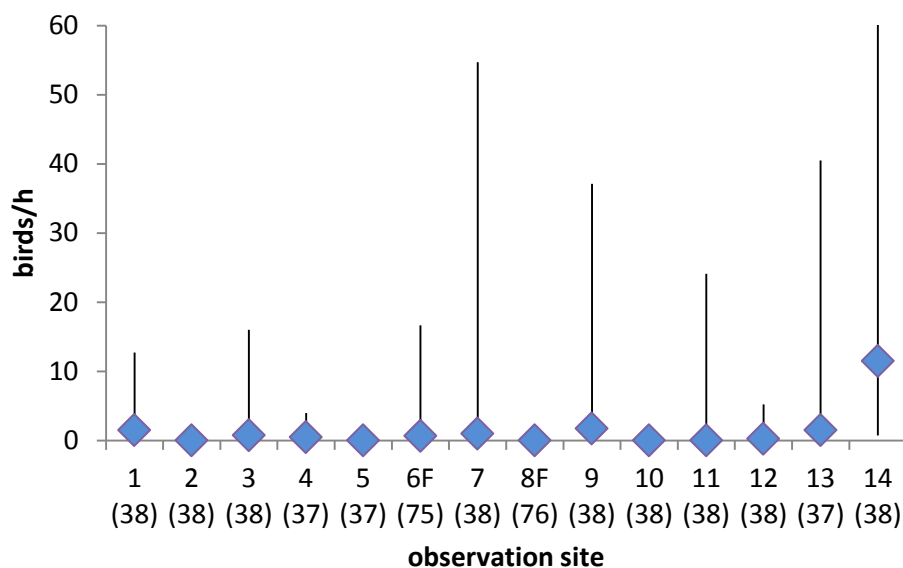

Figure 4.48: Comparison of migration rates (birds/h (blue) and records/h (light blue)) at the 14 observation sites in spring 2017 (median, 1st and 3rd quartile over all observation units; sample size (i.e. no. of observation units) at each observation site is given in brackets)

Considering the median it becomes apparent that most of the time migratory activity was (very) low (see Figure 4.48). At five of the 14 sites no bird was recorded in more than half of all observation units and, hence, the median was equal to zero. At ten observation sites the median was equal to or even less than 1.0 bird/h. Only site 14 migrating soaring birds were recorded during most of the observation units leading to a comparably higher median 11.5 birds/h (Figure 4.48) indicating a higher migration rate in the south of the project area.

When analysing migration rates at each observation site by simply dividing the number of birds by the observation time migratory activity was again highest at observation site 3 (Figure 4.49 and Map 4.6). As given before, this result was highly related with the number of large flocks (with more than 100 individuals). At observation site 3 the number of such flocks was obviously higher than at all other sites (Figure 4.49).

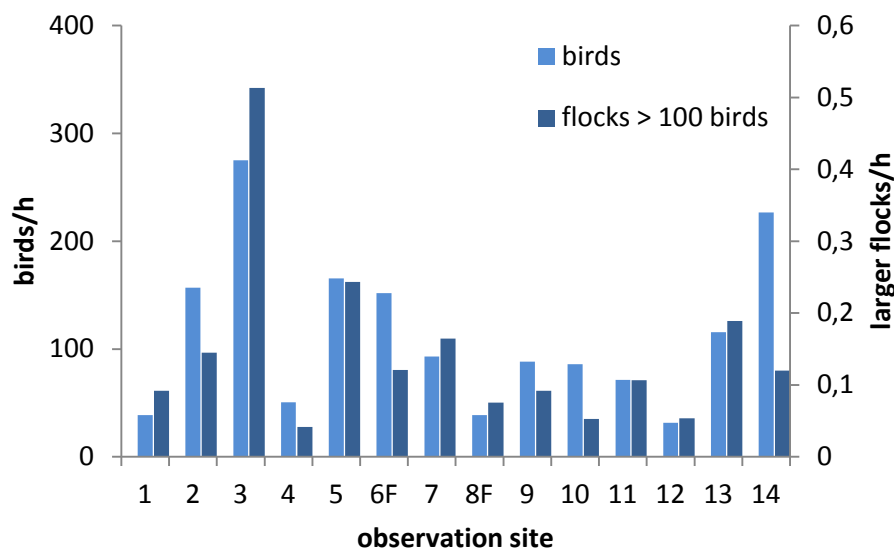

Figure 4.49: Migration rate (birds/h) and larger flocks (with > 100 birds)/h at the 14 observation sites

In most cases application of Wilcoxon signed-rank test did not reveal a significant difference in migration rates (birds/h and records/h) during synchronous observation units at two sites (Table 4.26). Significant differences appeared when comparing migration rates obtained at observation sites 3 and 11 (only for records/h), sites 5 and 13 (for both birds/h and records/h) and sites 7 and 14 (only records/h). Nevertheless, no spatial migration patterns can be derived by these results.

Table 4.26: Comparing migration rate (birds/h and records/h) at observation sites during synchronous observation units (results of Wilcoxon signed-rank test for paired samples: significant difference (if $p < 0.05$) are given in bold)

pair of obs. sites	birds/h		records/h	
	V	p	V	p
1 / 9	226.0	0.673	199.5	0.810
2 / 10	127.5	0.070	101.5	0.491
3 / 11	198.0	0.576	255.0	0.044
4 / 12	161.0	0.979	120.5	0.603
5 / 13	109.0	0.033	65.0	0.003
7 / 14	226.5	0.489	124.0	0.009

Map 4.6
Mean migration rate of target species (birds/h) obtained at observation sites in the project area in spring 2017

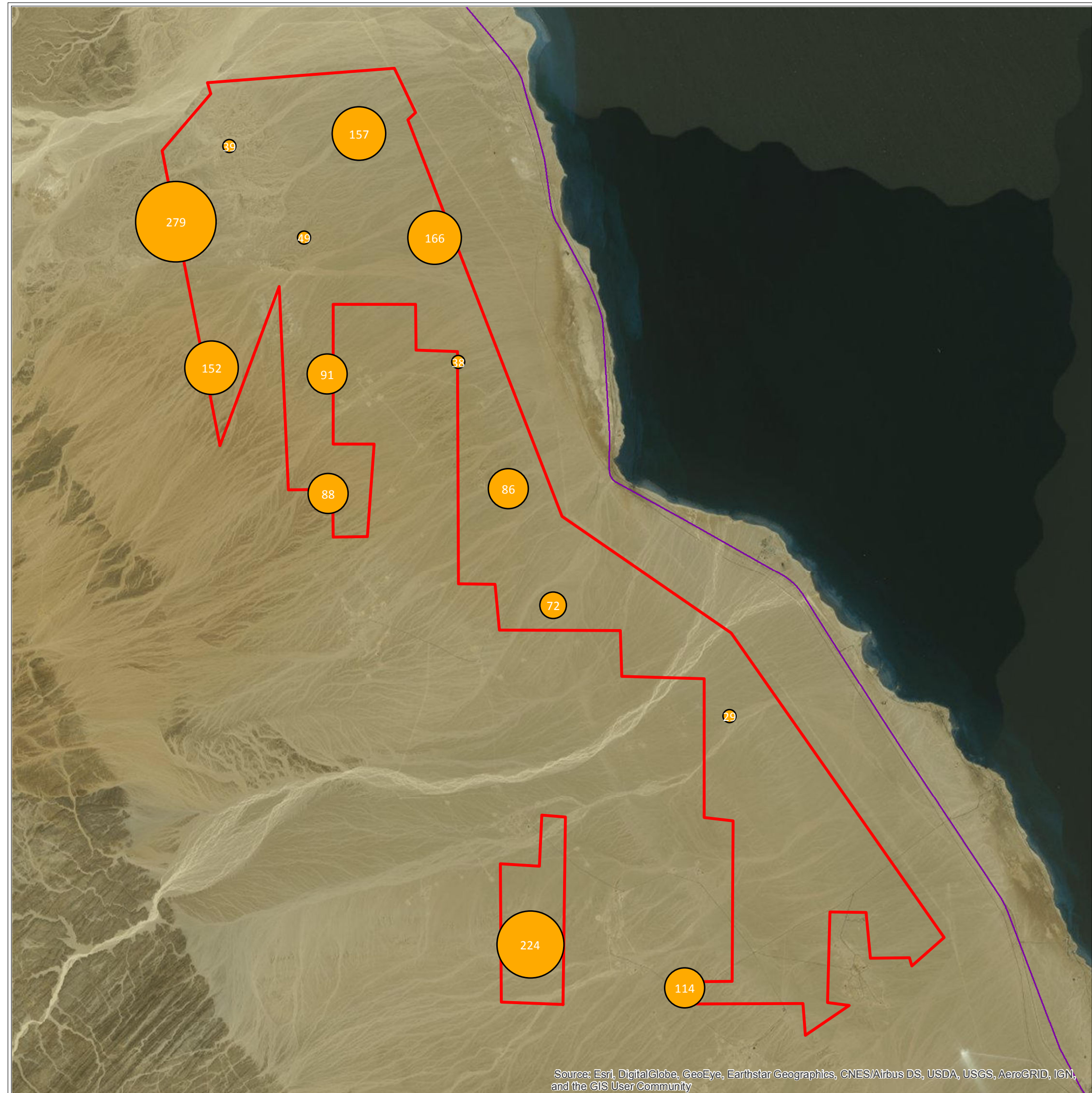

Project Area

boundaries of the project area

existing roads

Overall Migration Rate (geometric interval)

< 50.0 birds / hour

50.0 to 74.9 birds / hour

75.0 to 114.9 birds / hour

115.0 to 174.9 birds / hour

175.0 to 269.9 birds / hour

> 269.9 birds / hour

● editor: Lars Gaedicke, July 31st 2017

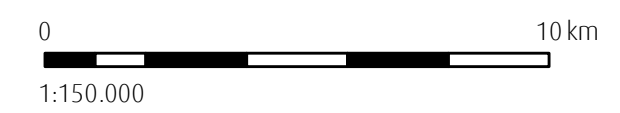

Map 4.7
Absolute number of birds and relative abundance of target species at each observation site in spring 2017



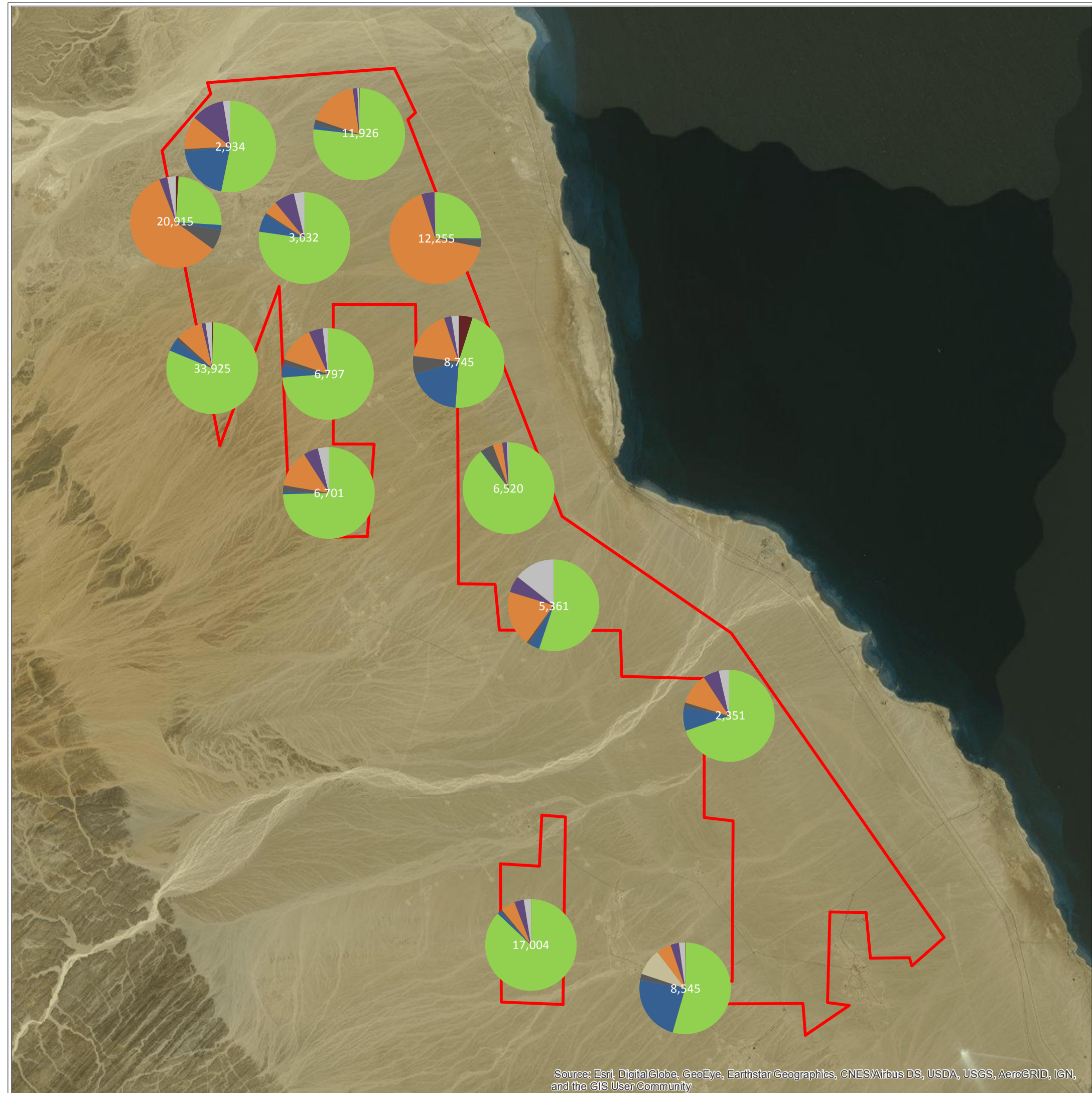
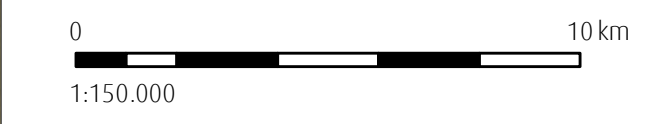

● editor: Lars Gaedicke, July 31st 2017





Map 4.8
Flight paths of Great White Pelican and White Stork during the study period in spring 2017





Project Area

-  boundaries of the project area
-  existing roads

Flight Paths of

-  Great White Pelican
-  White Stork

Number of Birds

-  1 to 10 individuals
-  11 to 100 individuals
-  101 to 1,000 individuals
-  1,001 to 2,000 individuals

● editor: Lars Gaedicke, July 31st 2017

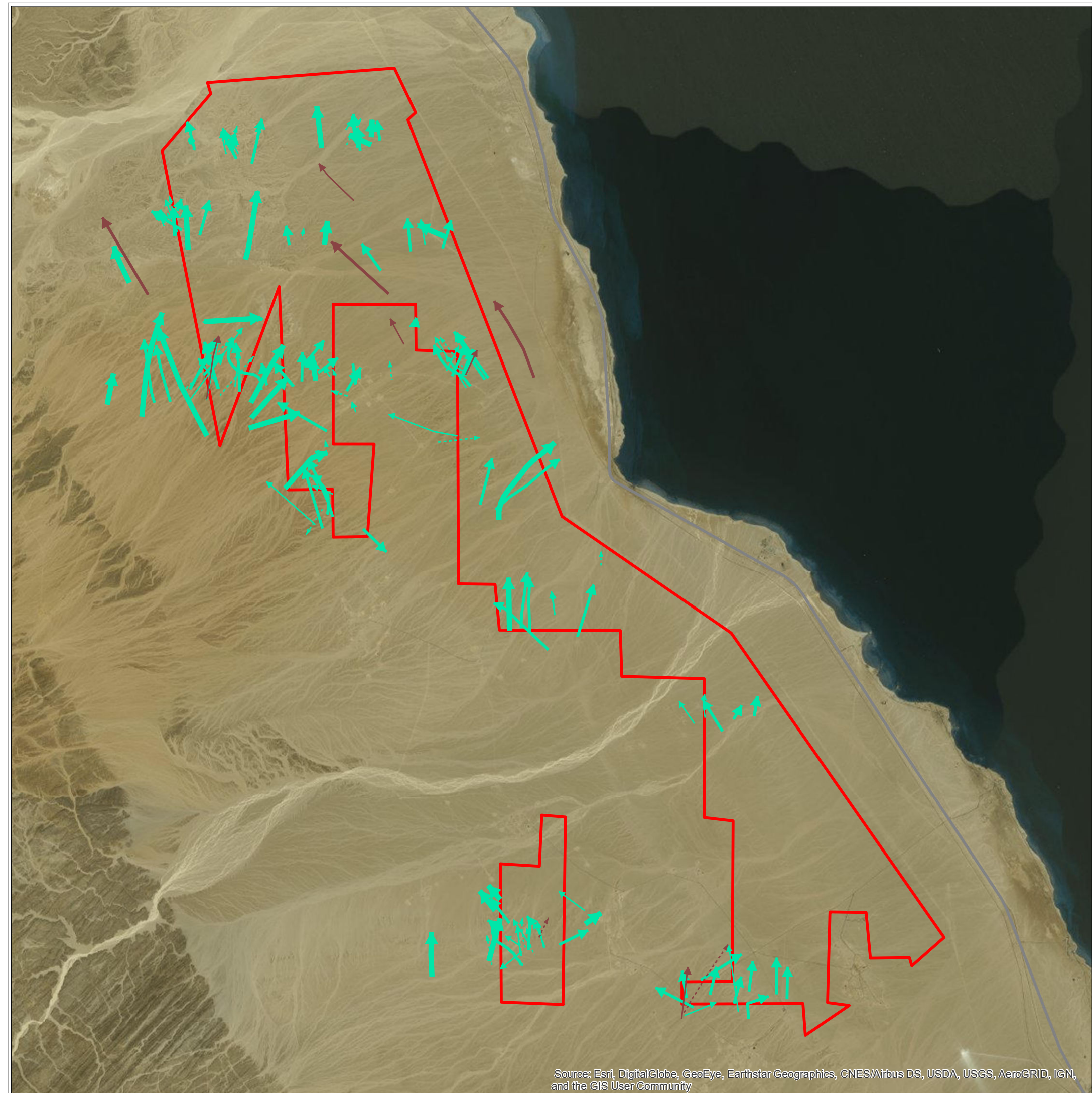
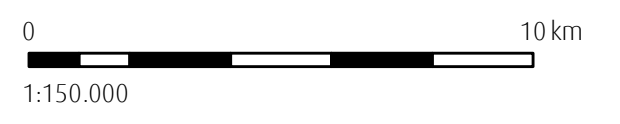

Summing up, the obtained spatial differences in migratory activity at the 14 observation sites are not caused by the existence of preferred flight paths or by avoidance of certain areas and, thus, do not reflect actual spatial differences in bird migration. The different migration rates refer to few large flocks which were rare events and which were recorded on single days only. Though the terrain is rising to the west and though the project area is somewhat hilly in its northern part, there are no remarkable topographic features which affect the spatial distribution of large soaring birds in spring. To conclude, no spatial differentiation can be made when describing and assessing migratory activity in the project area in spring.

Wind Speed and Wind Direction

In spring 2017 medium and low wind speed from northern directions was dominant during standardized observations of migrating birds (Figure 4.50).

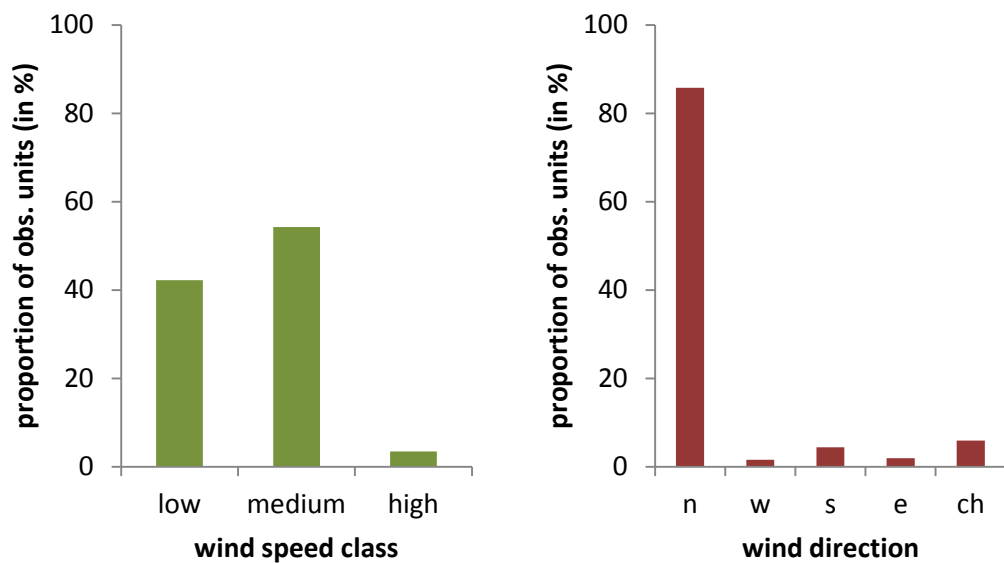

Figure 4.50: Wind speed (left) and wind direction (right) obtained in the study area in spring 2017 (ch.= changing)

The relation between migratory activity and the prevailing wind regime in spring 2017 is not fully in accordance with what was derived in the project area in spring 2016 (see Chapter 4.3.4.4.1). The main findings can be summarized as follows:

- The majority of birds (and records) occurred in situations with low and medium wind speeds (Figure 4.51). The relative abundance of birds and records in low wind situations was clearly higher than could be expected from the portion of according observation units (Figure 4.52). In contrast, the portion of birds and records registered in high wind speed situations was extremely low.
- The vast majority of birds was registered in conditions with northern wind directions (Figure 4.51). In contrast to spring 2016, the relative abundance of birds and records more or less matched with the proportion of according observational units (see Figure 4.52).
- Only very small numbers of birds and records were recorded in situations with southern wind directions or changing wind conditions (Figure 4.51). Again, the portions of birds/records that occurred in tailwind conditions or during changing wind directions more or less met the expectations (Figure 4.52).

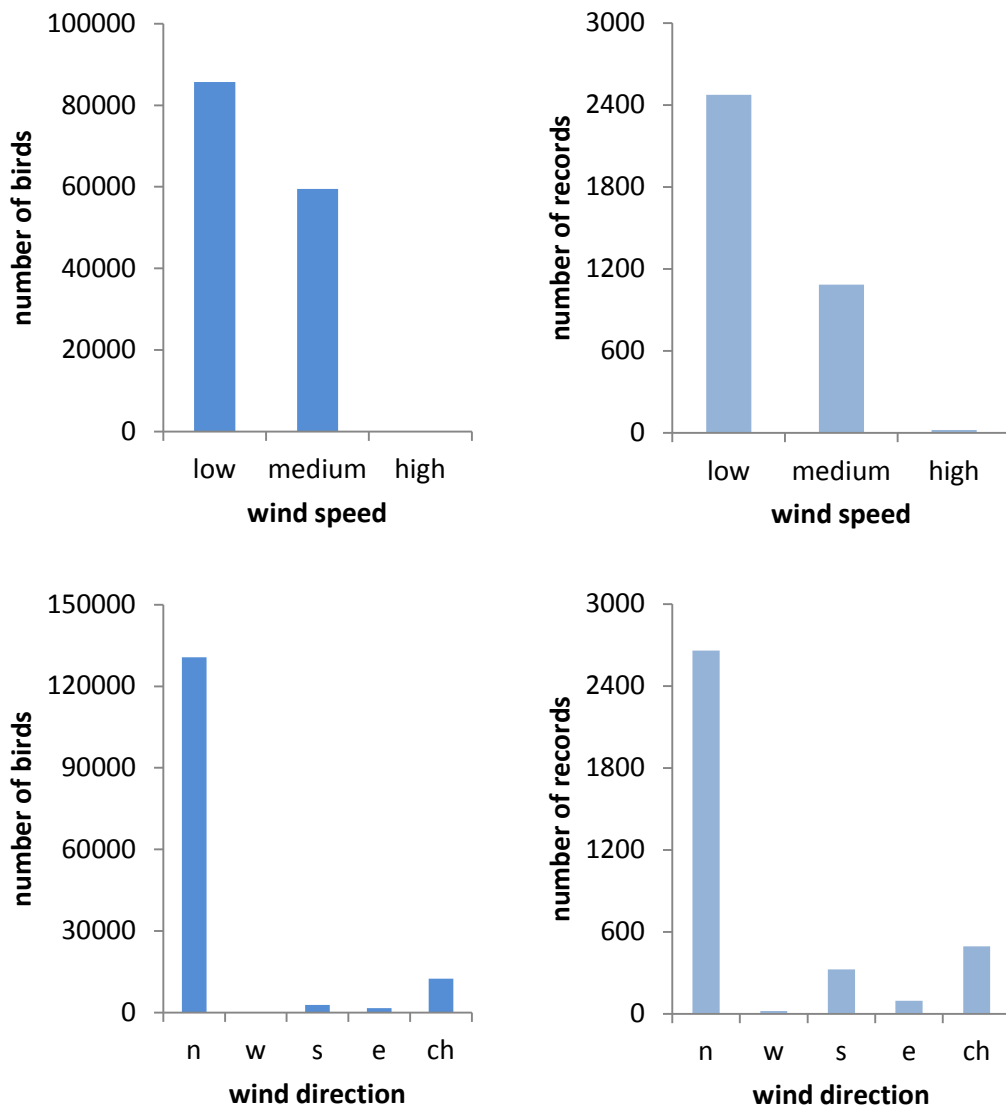

Figure 4.51: Total numbers of birds (left) and records (right) registered in the study area during certain wind speed (above) and wind direction (below) conditions in spring 2017

- Migration rates were highest in times of low wind speeds and winds from northern or from different (changing) directions (Figure 4.53). Nevertheless the number of records/h was highest during situations in which low wind speeds and winds from southern directions prevailed. During strong wind conditions there was almost no migratory activity (Figure 4.53).

To conclude, the analysis revealed no clear indication that spring migration was higher in conditions with winds from southern directions. This might be caused by the fact that brief periods with southern winds appeared in March only, but were very rare in April and May 2017 indicating that the overall conditions in 2017 might have been less favourable than in spring 2016. Nevertheless, large soaring birds apparently preferred favourable conditions for migration in spring 2017 too, i.e. times of low wind speeds.

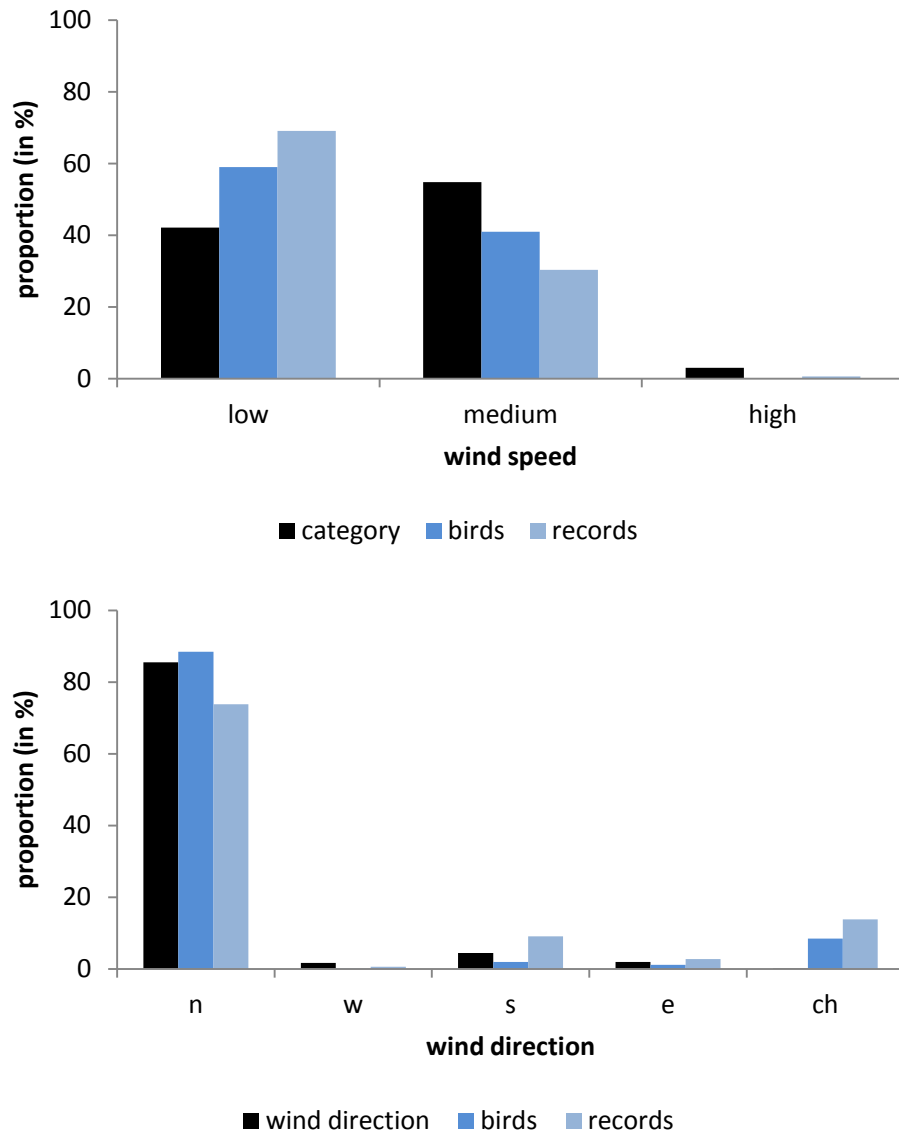

Figure 4.52: Proportion of observational time (n=1,351.1 hours) during different wind speed (above) and wind direction (below) conditions and relative abundance (in %) of birds (n=147,611) and records (n=3,601) registered during the according wind conditions in spring 2017

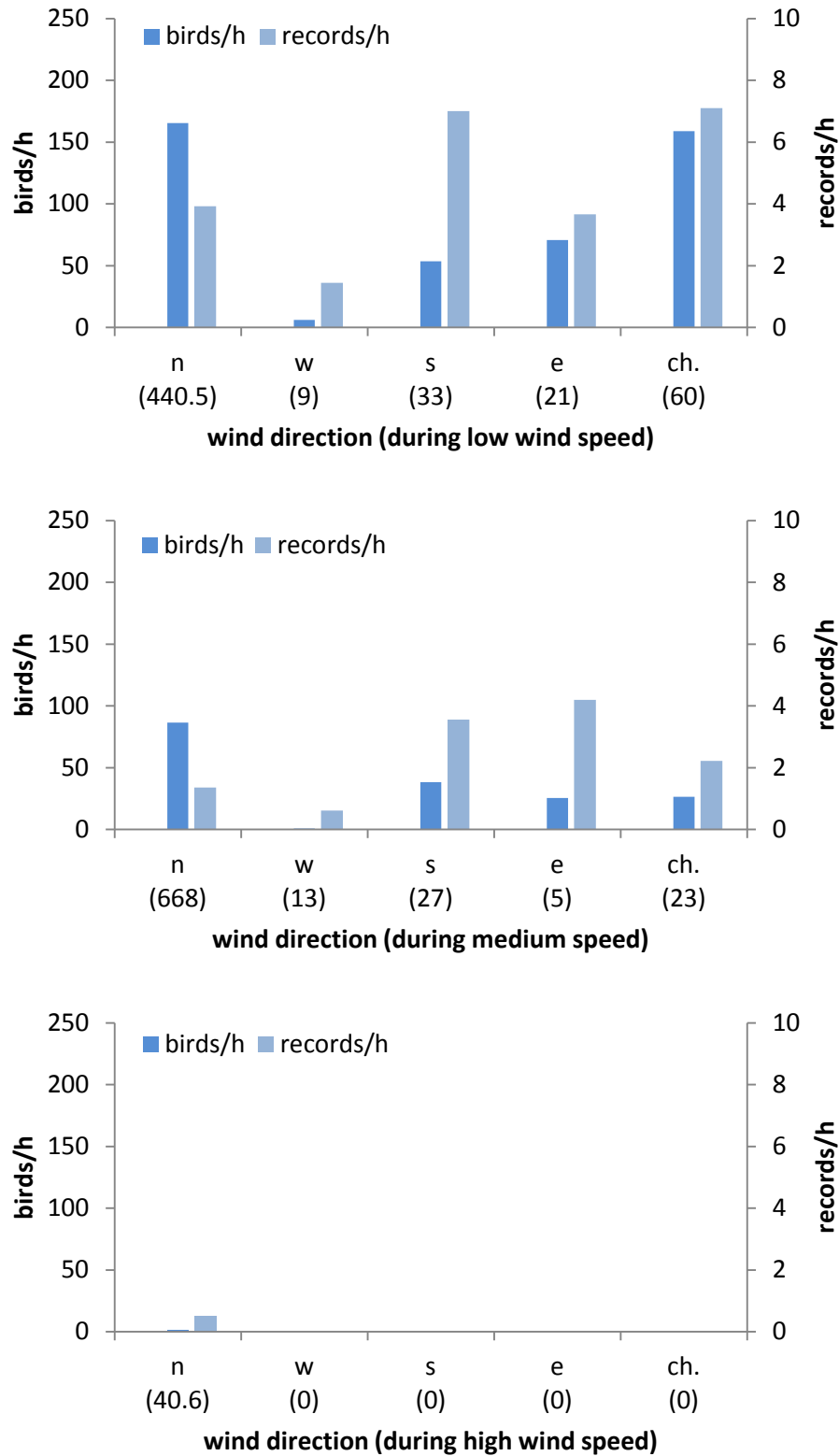

Figure 4.53: Migration rates (birds/h and records/h) obtained during different prevailing wind regimes (low (above), medium (middle) and high (below) wind speeds in spring 2017; the observational time for each wind regime is given in brackets)

Other Observations of Migrating Birds

Large soaring birds were recorded by chance (i.e. not during standardized observations) in nameable numbers in the project area in spring 2017 (Table 4.27).

In addition, migrating birds of species that are of minor relevance for the impact assessment were recorded during standardized observation units or by chance in nameable numbers in the project area, too (Table 4.28).

Table 4.27: Number of migrating birds of target species recorded by chance in the project area in spring 2017

species	scientific name	no. of birds
Great White Pelican	<i>Pelecanus onocrotalus</i>	1
White Stork	<i>Ciconia ciconia</i>	5,001
Osprey	<i>Pandion haliaetus</i>	1
European Honey Buzzard	<i>Pernis apivorus</i>	205
Black Kite	<i>Milvus migrans</i>	102
Egyptian Vulture	<i>Neophron percnopterus</i>	2
Short-toed Snake Eagle	<i>Circaetus gallicus</i>	5
Pallid Harrier	<i>Circus macrourus</i>	4
Eurasian Sparrowhawk	<i>Accipiter nisus</i>	1
Steppe Buzzard	<i>Buteo buteo vulpinus</i>	1,086
Lesser Spotted Eagle	<i>Aquila pomarina</i>	1
Steppe Eagle	<i>Aquila nipalensis</i>	178
Booted Eagle	<i>Aquila pennata</i>	3
Common Kestrel	<i>Falco tinnunculus</i>	21
Falcon	<i>Falco spec.</i>	1
unidentified raptor	-	4

Table 4.28: Number of migrating birds of species that are of minor relevance for the impact assessment recorded in the project area in spring 2017

species	scientific name	no. of birds
Northern Pintail	<i>Anas acuta</i>	1
Great Cormorant	<i>Phalacrocorax carbo</i>	860
Green Heron	<i>Butorides virescens</i>	40
Sanderling	<i>Calidris alba</i>	3
Collared Pratincole	<i>Glareola pratincola</i>	8
Wader	-	42
Whiskered Tern	<i>Chlidonias hybridus</i>	29
European Turtle Dove	<i>Streptopelia turtur</i>	4
Alpine Swift	<i>Tachymarptis melba</i>	71
Common Swift	<i>Apus apus</i>	9
Swift	<i>Apus spec.</i>	8
Green Bee-eater	<i>Merops orientalis</i>	4
Blue-cheeked Bee-eater	<i>Merops persicus</i>	13
European Bee-eater	<i>Merops apiaster</i>	3,053
Bee-eater spec.	<i>Merops spec.</i>	298
European Roller	<i>Coracias garrulus</i>	1
Eurasian Hoopoe	<i>Upupa epops</i>	12
Greater Short-toed Lark	<i>Calandrella brachydactyla</i>	2,082
Lark spec.	-	30
Barn Swallow	<i>Hirundo rustica</i>	2,242
Red-rumped Swallow	<i>Cecropis daurica</i>	15
Common House Martin	<i>Delichon urbica</i>	89
Swallow spec.	-	1

4.3.5.4.3 Alfamar Area in Spring 2016

Number of Migrating Birds, Species Composition and Flock Size

During the study period in spring 2016 a total 38,502 birds from 25 relevant species were observed at distances of up to 2.5 km from the observation site (Table 4.29). White Stork, European Honey Buzzard, Steppe Buzzard, Black Kite, Great White Pelican and Steppe Eagle were the most numerous species. These six species represent 98 % of all registered individuals (Table 4.29). About 58 % of all registered birds were White Storks, thus the White Stork was by far the most numerous species.

Although large flocks were rarely recorded, they have a strong effect on the data set. In total there were nine flocks (about 1 % of all records) with more than thousand individuals, representing about 48 % of all migrating birds (Figure 4.54). In contrast, the fraction of birds migrating individually was about 38 % of all records yet 1 % of all birds (Figure 4.54). Together, single birds and flocks with up to ten individuals constitute about 75 % of all records.

Overall 1,014 records (of an individual or a flock) were registered at distances of up to 2.5 km from the observation site. Steppe Buzzard (23 %), Black Kite (19 %), Steppe Eagle (18 %) and European Honey Buzzard (12 %) were recorded most often. In contrast White Stork (3 %) and Great White Pelican (1 %) were recorded occasionally.

Five species of special interest with a total of 1,462 individuals occurred during observations:

- Egyptian Vulture: 6 individuals
- Pallid Harrier: 5 individuals
- Greater Spotted Eagle: 3 individuals
- Steppe Eagle: 1,433 individuals
- Eastern Imperial Eagle: 15 individuals

Note that there might have been further individuals of these or other species which might be found under Pallid / Montagu's Harrier and Harrier as well as Eagle, Falcon or unidentified raptor.

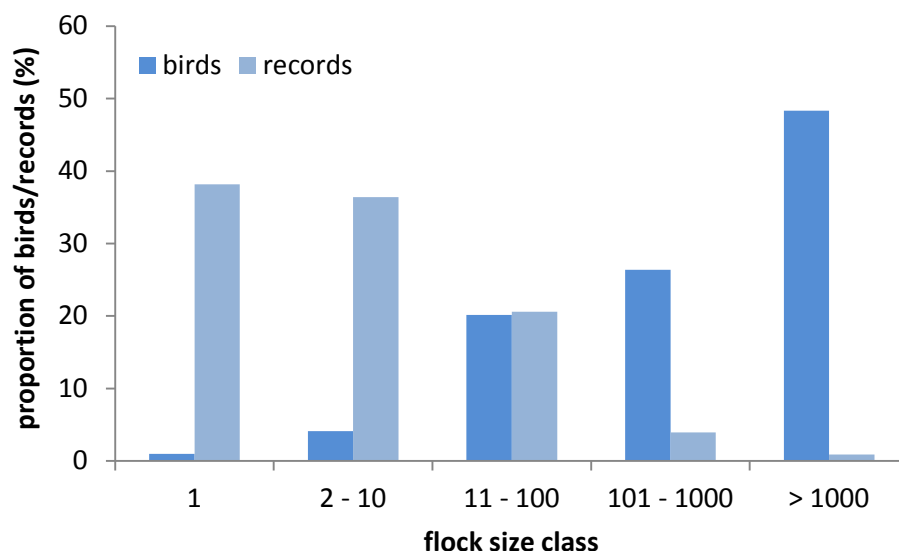

Figure 4.54: Relative abundance (proportion in %) of birds/records registered at distances of up to 2.5 km in different flock size classes in the Alfamar area in spring 2016

Table 4.29: Number of birds and records registered in the Alfanar area (i.e. at distances of up to 2.5 km to the observation site) in the study period (February 27th and May 26th) in spring 2016

species	scientific name	birds	records
Great White Pelican	<i>Pelecanus onocrotalus</i>	1,577	11
Black Stork	<i>Ciconia nigra</i>	277	24
White Stork	<i>Ciconia ciconia</i>	22,455	33
European Honey Buzzard	<i>Pernis apivorus</i>	6,391	126
Black Kite	<i>Milvus migrans</i>	1,927	192
Egyptian Vulture	<i>Neophron percnopterus</i>	6	6
Short-toed Snake Eagle	<i>Circaetus gallicus</i>	57	42
Marsh Harrier	<i>Circus aeruginosus</i>	45	24
Pallid Harrier	<i>Circus macrourus</i>	5	5
Montagu's Harrier	<i>Circus pygargus</i>	4	4
Pallid / Montagu's Harrier	<i>Circus macrourus / pygargus</i>	3	2
Harrier	<i>Circus spec.</i>	4	3
Levant Sparrowhawk	<i>Accipiter brevipes</i>	20	1
Eurasian Sparrowhawk	<i>Accipiter nisus</i>	19	16
Sparrowhawk spec.	<i>Accipiter spec.</i>	1	1
Steppe Buzzard	<i>Buteo buteo vulpinus</i>	3,874	234
Long-legged Buzzard	<i>Buteo rufinus</i>	25	20
Buzzard	<i>Buteo spec.</i>	41	2
Lesser Spotted Eagle	<i>Aquila pomarina</i>	15	11
Greater Spotted Eagle	<i>Aquila clanga</i>	3	1
Steppe Eagle	<i>Aquila nipalensis</i>	1,433	178
Eastern Imperial Eagle	<i>Aquila heliaca</i>	15	13
Booted Eagle	<i>Aquila pennata</i>	28	19
Eagle		15	6
Lesser Kestrel	<i>Falco naumanni</i>	5	4
Common Kestrel	<i>Falco tinnunculus</i>	21	18
Eleonora's Falcon	<i>Falco eleonora</i>	1	1
Lanner Falcon	<i>Falco biarmicus</i>	2	2
Barbary Falcon	<i>Falco pelegrinoides</i>	2	1
Falcon	<i>Falco spec.</i>	3	3
unidentified raptor	-	65	8
Common Crane	<i>Grus grus</i>	163	3
total		38,502	1,014

Classification due to IUCN Red List of Threatened Birds: "Endangered", "Vulnerable", "Near Threatened". Species listed as "Least Concern" or not considered in the IUCN Red List are not colored.

Seasonal Distribution of Migratory Activity

In spring 2016 the number of birds/h and records/h increased during the first weeks of the survey, peaked in the second half of the study period and decreased afterwards again (Figure 4.55). Most birds passed the study area between mid of March and end of April. Between March 10th and May 10th 96 % of all birds (and 88 % of all records) were registered.

Birds did not migrate regularly in equal numbers, but migration concentrated on few days or periods. During nine days 30,272 birds were recorded in the Alfancar area (Table 4.30). Thus, within about 12 % of all observation days 79 % of all birds were registered. During these nine days all flocks with more than 1,000 individuals and 60 % of all flocks with 101 to 1,000 individuals were observed.

The number of records was high within certain days, too, and thus highly influenced the illustrated phenology. During six days (representing only 8 % of all observation days) about 35 % of all records were registered. So, single days or observation units had a strong effect on the overall dataset.

Those days with highest migratory activity in the Alfancar area were very much in accordance with the “peak-“days in the project area and the ACWA in spring 2016. However, single “peak-“days in the project area (April 21st, May 1st and 2nd) did not belong to those days with highest migratory activity in the Alfancar area. This result is probably caused by the different study periods in the two areas in spring 2016 (no observations before April 15th in the project area lead to relatively more “peak”-days in April and May).

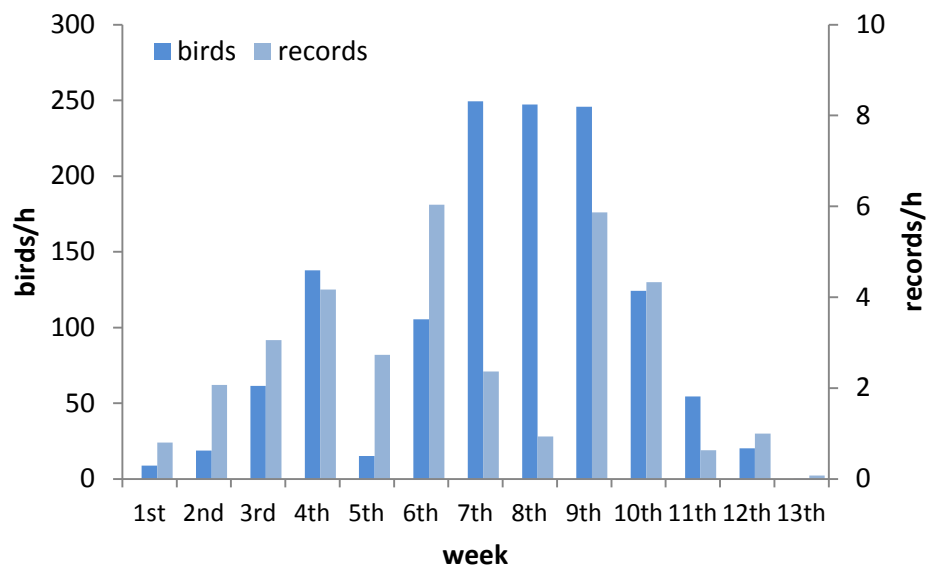

Figure 4.55: Migratory activity (birds/h and records/h) in different weeks of the study period in spring 2016 (only birds at distances of up to 2.5 km to the observation site; to correct different observational time the number of birds/records was divided by observational time of the particular week; 1st week: February 27th to March 3rd)

Table 4.30: Characteristics of migration on nine days with (very) high migratory activity in spring 2016

date	number of birds	share of birds (%)	remark
13.03.2016	1,503	4	554 Black Kites and 812 Steppe Buzzards within overall 26 flocks in the afternoon
24.03.2016	2,216	6	2,016 White Storks (thereof 2,000 in one flock in the morning)
02.04.2016	2,026	5	1,900 White Storks (6 flocks) during midday and afternoon
09.04.2016	6,383	17	5,150 White Storks (6 flocks) during midday and 1,000 Great White Pelicans (1 flock) during afternoon
20.04.2016	7,049	18	7,000 White Storks (2 flocks) during afternoon
24.04.2016	2,609	7	1,901 White Storks (4 flocks) during afternoon
26.04.2016	3,673	10	3,098 European Honey Buzzards (49 % of the overall number of this species), mostly during midday
03.05.2016	3,261	8	1,502 White Storks (3 flocks) during midday 1,567 European Honey Buzzards mostly during midday
08.05.2016	1,552	4	1,500 White Storks (1 flock) during afternoon
total	30,272	79	

Daily Distribution of Migratory Activity

The data from spring 2016 point towards a higher migration rate during midday and afternoon, in comparison to morning (Figure 4.56). However, in general migratory activity was highly variable within different periods of the day (see high standard deviation in Figure 4.56).

As mentioned above single events had a strong effect on the presented data. In only 10 observation units (on nine days) at total of 29,385 individuals were registered (about 76 % of all registered birds). A single event with many individuals leads to a (disproportionate high) increase of the arithmetical mean. The high average migration rate during midday and afternoon, in comparison to morning, was mainly caused by six observation units during midday and five observation units during afternoon (see also Table 4.30). To conclude, this pattern might not represent the migratory activity for the whole study period, as it might be caused by chance through single events, which had a strong effect on the data.

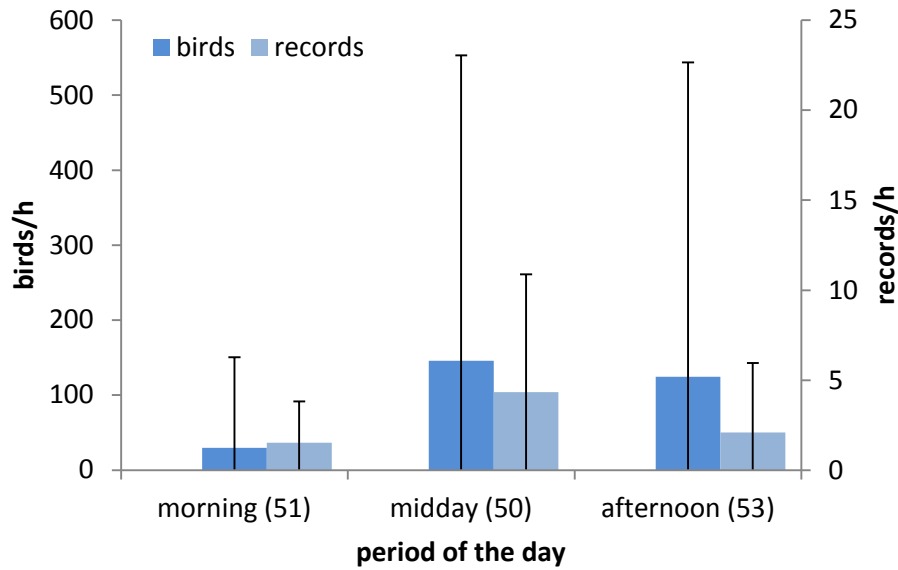

Figure 4.56: Average migratory activity (birds/h and records/h) at distances of up to 2.5 km to the observation site during different periods of the day in spring 2016 (arithmetical mean and standard deviation; sample size (i.e. no. of observation days) for each period is given in brackets)

Altitude of Migrating Birds

In spring 2016 about 69 % of all birds and 65 % of all records were recorded at altitudes above 120 m (Table 4.31). About 28 % of all birds and 27 % of all records were - at least temporary - registered at altitudes from 30 to 120 m (roughly representing the rotor swept area of wind turbines). Only few birds/records migrated exclusively at altitudes below 30 m.

Table 4.31: Number of birds (above) and records (below) observed at distances of up to 2.5 km to the observation site at different flight altitude classes registered in spring 2016

		flight altitude maximum (in m)		
		< 30 m	> 30 - 120 m	> 120 m
flight altitude minimum (in m)	birds			
	< 30 m	1,063	81	19
	> 30 - 120 m		4,555	6,212
> 120 m			26,501	
		flight altitude maximum (in m)		
		< 30 m	> 30 - 120 m	> 120 m
flight altitude minimum (in m)	records			
	< 30 m	88	15	10
	> 30 - 120 m		169	74
> 120 m			649	

Flight Directions

As usual during the migration period in autumn, the majority of birds (about 89 %) and records (about 81 %) migrated in southern directions. About 7 % of all birds and 10 % of all records headed for western directions.

Wind Speed and Wind Direction

During the survey in the Alfamar area medium wind speed from northern directions was dominant in spring 2016 (Figure 4.57).

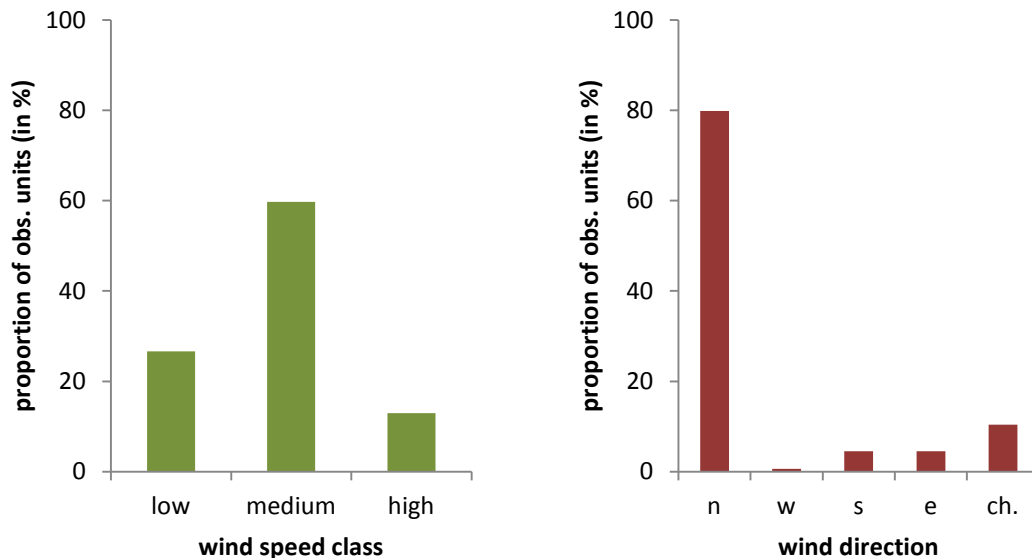

Figure 4.57: Wind speed (left) and wind direction (right) in spring 2016 (ch.= changing)

The relation between migratory activity and the prevailing wind regime is very much in accordance with what was derived in the project area in spring 2016 (see Chapter 4.3.4.4.1) and can be summarized as follows:

- The majority of birds (and records) occurred in situations with low and medium wind speeds (Figure 4.58). The relative abundance of birds and records in low wind situations was clearly higher than could be expected from the portion of according observation unites (Figure 4.59). In contrast, the portion of birds and records registered in high wind speed situations was very low.
- Most birds were registered in conditions with northern wind directions (Figure 4.58), but less than could be expected from the proportion of according observational units (see Figure 4.59).
- A small number of birds and records were recorded in situations with southern wind directions or changing wind conditions (Figure 4.58). However, the portions of birds/records that occurred in tailwind conditions or during changing wind directions were notably higher than could be expected from the portion of according observational units (Figure 4.59).

To conclude, the analysis revealed that spring migration in the Alfamar area was relatively higher during favourable (with wind from southern directions or with low wind speeds) and lower in unfavourable conditions (i.e. (strong) northern wind). Nevertheless, the highest number of birds migrated in headwind conditions, as these were the most frequent conditions in spring 2016 and in general. Hence, migratory activity was not only affected by the wind regime, but also by other internal and external factors.

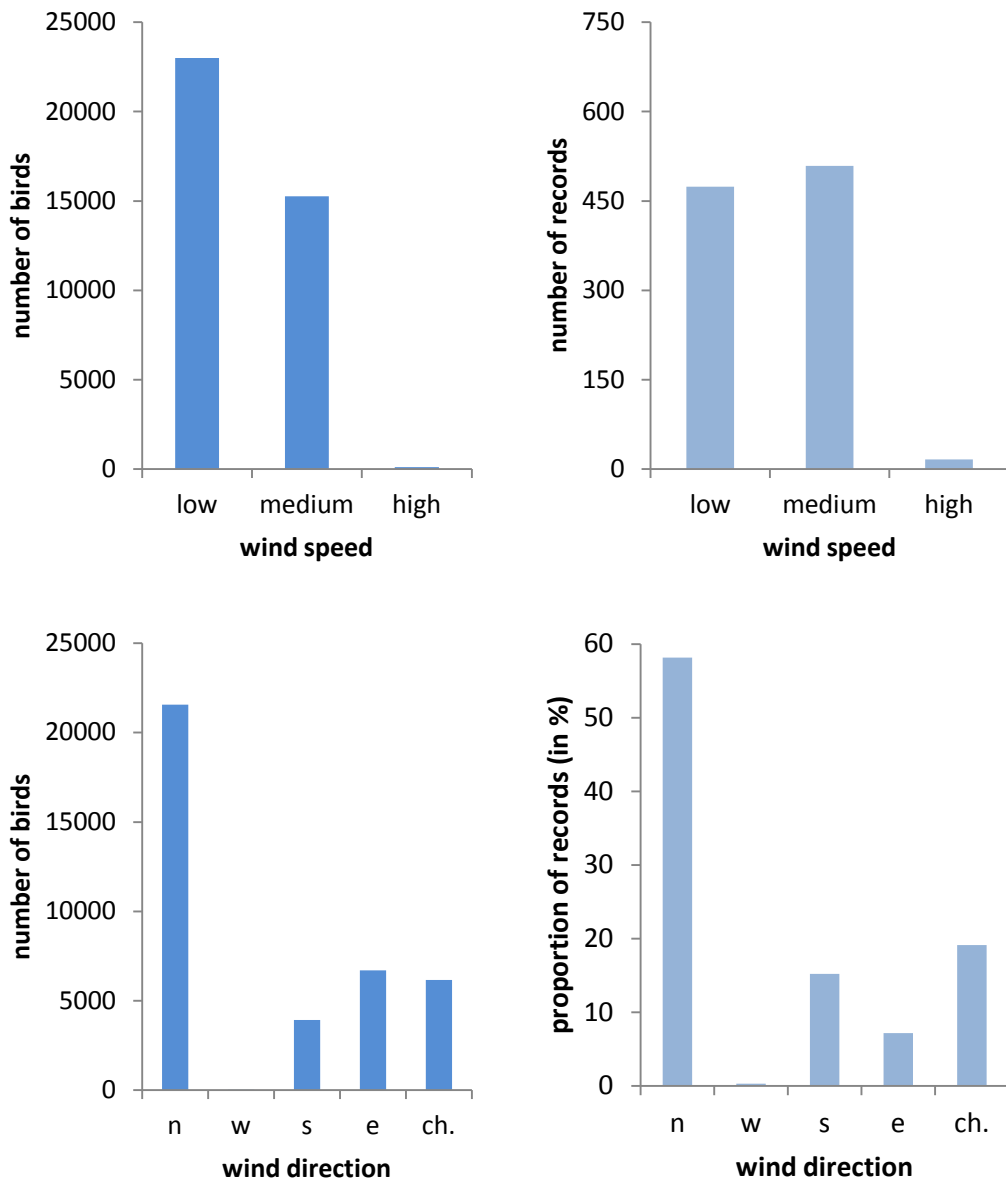

Figure 4.58: Total numbers of birds (left) and records (right) registered in the Alfancar area during certain wind speed (above) and wind direction (below) conditions in spring 2016

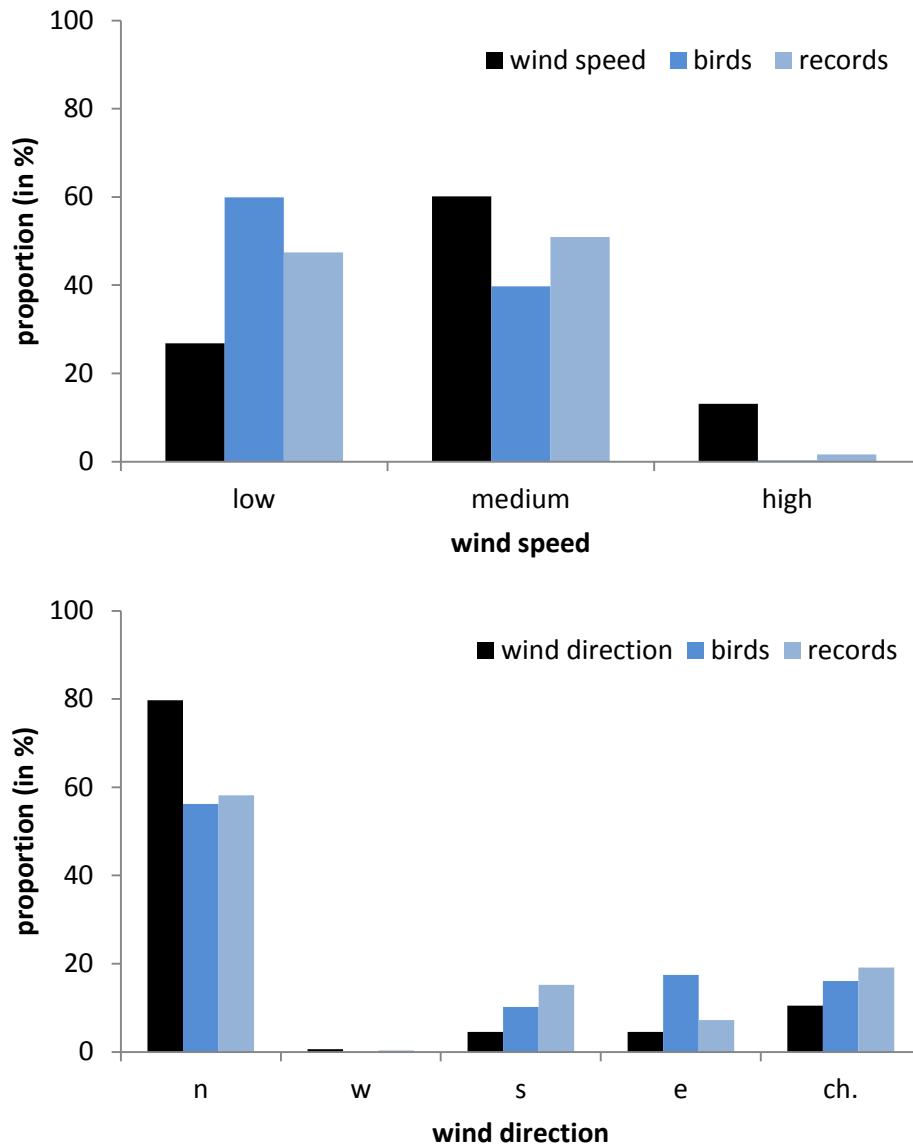

Figure 4.59: Proportion of observation units with different wind speed (above) and wind directions (below) and relative abundance (in %) of birds and records registered in spring 2016 during the according wind conditions

Other Observations of Migrating Birds

While driving through the study area in spring 2016 few records of target species were obtained. Most numerous was Steppe Eagle (145 migrating birds) that was recorded three times on March 7th within a period of about 10 minutes. Moreover two unidentified Harriers and one Long-legged Buzzard were observed by chance in the Alfamar area.

In addition, migrating birds of species that are of minor relevance for the impact assessment were occasionally recorded during standardized observation units or by chance in the Alfamar area (see Table 4.32).

Table 4.32: Number of migrating birds of target species recorded by chance or of species that are of minor relevance for the impact assessment recorded in the Alfamar area in spring 2016

species	scientific name	birds
Barn Swallow	<i>Hirundo rustica</i>	22
Common Chiffchaff	<i>Phylloscopus collybita</i>	1
White Wagtail	<i>Motacilla alba</i>	45
Red-Throated Pipit	<i>Anthus cervinus</i>	3
Water Pipit	<i>Anthus spinoletta</i>	1
Lark spec.	-	21
Pipit spec.	<i>Anthus spec.</i>	6

4.3.5.4.4 ACWA Area in Spring 2016

Number of Migrating Birds, Species Composition and Flock Size

A total of 74,579 birds from 30 relevant species were observed at distances of up to 2 km from the observation sites in the ACWA area in spring 2016 (Table 4.33). White Stork, Steppe Buzzard, European Honey Buzzard, Great White Pelican, Steppe Eagle and Black Kite were the most numerous species. These six species represent 97 % of all registered individuals (Table 4.33). About 58 % of all registered birds were White Storks, thus the White Stork was by far the most numerous species.

Although large flocks were rarely recorded, they have a strong effect on the data set. In total there were ten flocks (< 1 % of all records) with more than 1,000 individuals, representing about 44 % of all migrating birds (Figure 4.60). In contrast, the fraction of birds migrating individually was about 39 % of all records yet about 1 % of all birds (Figure 4.60). Together, single birds and flocks with up to ten individuals constitute about 80 % of all records.

Overall 2,766 records (of an individual or a flock) were registered at distances of up to 2 km from the observation sites. Steppe Buzzard (26 %), Steppe Eagle (19 %) and Black Kite (15 %) and European Honey Buzzard (11 %) were recorded most often. In contrast White Stork (3 %) and Great White Pelican (1 %) were recorded occasionally.

A total of 2,399 individuals of “Endangered” species (50 Egyptian Vultures and 2,349 Steppe Eagles) and 29 individuals of “Vulnerable” species (12 Greater Spotted Eagles and 17 Eastern Imperial Eagles) were recorded in the ACWA area in spring 2016. In addition, 24 recorded individuals belong to species listed as “Near Threatened” (18 Pallid Harriers and 6 Sooty Falcons). Note that there might have been further individuals of these or other species which might be found under Pallid / Montagu’s Harrier and Harrier as well as Eagle, Falcon or unidentified raptor.

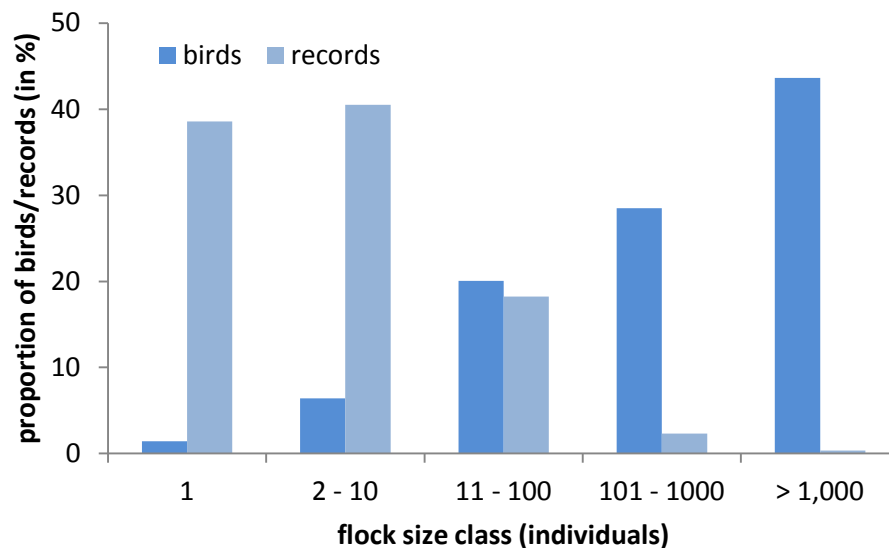

Figure 4.60: Relative abundance (proportion in %) of birds/records registered at distances of up to 2.5 km in different flock size classes in the ACWA area in spring 2016

Table 4.33: Number of birds and records registered in the ACWA area (i.e. at distances of up to 2.0 km from the observation sites) in the study period (February 27th and May 25th) in spring 2016

species	scientific name	birds	records
Great White Pelican	<i>Pelecanus onocrotalus</i>	6,242	14
Cattle Egret	<i>Bubulcus ibis</i>	1	1
Black Stork	<i>Ciconia nigra</i>	385	41
White Stork	<i>Ciconia ciconia</i>	43,450	85
Osprey	<i>Pandion haliaetus</i>	4	4
European Honey Buzzard	<i>Pernis apivorus</i>	8,191	299
Black Kite	<i>Milvus migrans</i>	1,859	408
Egyptian Vulture	<i>Neophron percnopterus</i>	50	35
Griffon Vulture	<i>Gyps fulvus</i>	1	1
Short-toed Snake Eagle	<i>Circaetus gallicus</i>	209	151
Marsh Harrier	<i>Circus aeruginosus</i>	44	36
Pallid Harrier	<i>Circus macrourus</i>	18	16
Montagu's Harrier	<i>Circus pygargus</i>	10	9
Harrier	<i>Circus spec.</i>	7	7
Levant Sparrowhawk	<i>Accipiter brevipes</i>	55	4
Eurasian Sparrowhawk	<i>Accipiter nisus</i>	22	17
Sparrowhawk spec.	<i>Accipiter spec.</i>	3	3
Steppe Buzzard	<i>Buteo buteo vulpinus</i>	10,154	717
Long-legged Buzzard	<i>Buteo rufinus</i>	67	41
Buzzard	<i>Buteo spec.</i>	7	3
Lesser Spotted Eagle	<i>Aquila pomarina</i>	403	100
Greater Spotted Eagle	<i>Aquila clanga</i>	12	10
Steppe Eagle	<i>Aquila nipalensis</i>	2,349	482
Eastern Imperial Eagle	<i>Aquila heliaca</i>	17	12
Golden Eagle	<i>Aquila chrysaetos</i>	1	1
Booted Eagle	<i>Aquila pennata</i>	130	92
Eagle	-	530	80
Lesser Kestrel	<i>Falco naumanni</i>	2	2
Common Kestrel	<i>Falco tinnunculus</i>	40	38
Eleonora's Falcon	<i>Falco eleonora</i>	3	2
Sooty Falcon	<i>Falco concolor</i>	6	5
Eurasian Hobby	<i>Falco subbuteo</i>	2	2
Barbary Falcon	<i>Falco pelegrinoides</i>	1	1
Falcon	<i>Falco spec.</i>	31	29
unidentified raptor	-	29	10
Common Crane	<i>Grus grus</i>	244	8
total		74,579	2,766

Classification due to IUCN Red List of Threatened Birds: "Near Threatened". Species listed as "Least Concern" or not considered in the IUCN Red List are not colored.

Seasonal Distribution of Migratory Activity

In spring 2016 the number of birds/h and records/h increased during the first weeks of the survey, peaked within the middle of the study period and decreased afterwards again (Figure 4.61). Most birds passed the study area between mid of March and end of April. Between March 10th and April 30th 85 % of all birds (and 81 % of all records) were registered.

Birds did not migrate regularly in equal numbers, but migration concentrated on few days or periods. During eight days 56,426 birds were recorded in the ACWA area (Table 4.34). Thus within about 10 % of all observation days 76 % of all birds were registered. During these eight days all flocks with more than 1,000 individuals and about 63 % of all flocks with 101 to 1,000 individuals were observed.

The number of records was high within certain days, too, and thus highly influenced the illustrated phenology. During ten days (representing about 14 % of the overall observational time) about 57 % of all records were registered.

Those days with highest migratory activity in the ACWA area were very much in accordance with the “peak-“days in the project area and the Alfamar area in spring 2016. However, single “peak-“days in the project area (April 21st, May 1st and 2nd) did not belong to those days with highest migratory activity in the Alfamar area. This result is probably caused by the different study periods in the two areas in spring 2016 (no observations before April 15th in the project area lead to relatively more “peak”-days in April and May).

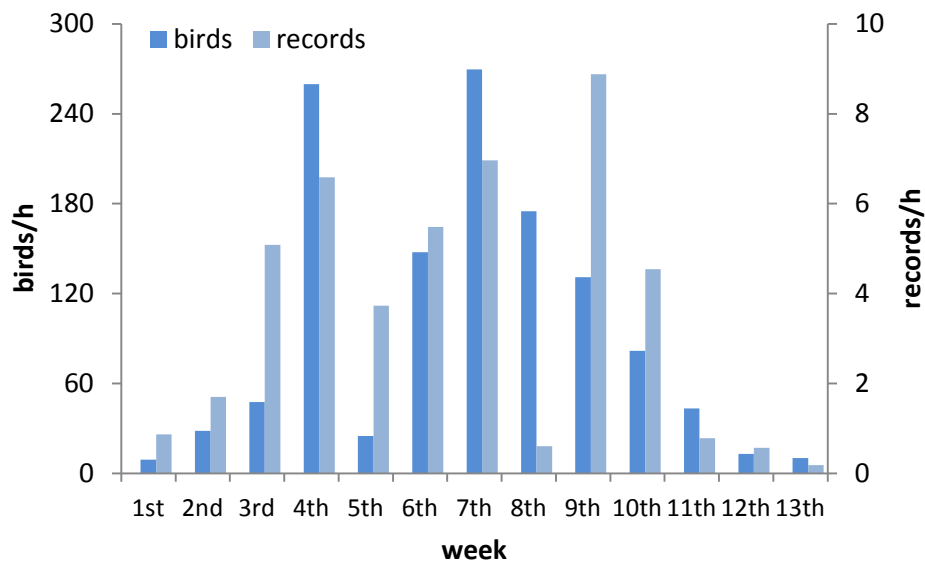

Figure 4.61: Migratory activity (birds/h and records/h) in different weeks in spring 2016 (only birds at distances of up to 2.0 km to the two observation sites; to correct different observational time the number of birds/records was divided by observational time of the particular week; February 27th to March 3rd)

Table 4.34: Characteristics of migration on ten days with (very) high migratory activity in spring 2016

date	number of birds	share of birds (%)	remark
24.03.2016	12,931	17	12,552 White Storks (thereof 12,500 in 3 flocks) during morning
02.04.2016	7,749	10	7,500 White Storks (thereof 7,400 in 10 flocks) during midday and afternoon
09.04.2016	9,553	13	3,990 White Storks (most of them in only 5 flocks) and 5,000 Great White Pelicans (most of them in only 1 flock) during midday and afternoon
10.04.2016	7,749	10	3,366 White Storks (thereof 2,000 in 1 flock) 1,388 Steppe Buzzards (101 records)
20.04.2016	10,241	14	10,200 White Storks (4 flocks) during midday and afternoon
26.04.2016	5,888	8	5,038 European Honey Buzzards (62 % of the overall number of this species) mostly during midday
03.05.2016	2,615	4	941 European Honey Buzzards 754 White Storks (600 in 1 flock) 596 Steppe Buzzards and other species
08.05.2016	2,452	3	2,350 White Storks (in 4 flocks, thereof 1 flock with 1,250 individuals) during afternoon
total	56,426	10	

Daily Distribution of Migratory Activity

The data from spring 2016 point towards a higher migration rate during midday, in comparison to morning and afternoon (Figure 4.62). However, in general migratory activity was highly variable within different periods of the day (see high standard deviation in Figure 4.62).

As mentioned above single events had a strong effect on the presented data. In only 13 observation units (on eight days) at total of 52,588 individuals were registered (about 71 % of all registered birds). A single event with many individuals leads to a (disproportionate high) increase of the arithmetical mean. The high average migration rate during midday, in comparison to morning and afternoon, was mainly caused by the observations during midday on April 9th, 20th and 26th, when higher numbers of Great White Pelican, White Stork and/or European Honey Buzzard, respectively, passed the study area (Table 4.34). To conclude, this pattern might not represent the migratory activity for the whole study period, as it might be caused by chance through single events, which had a strong effect on the data.

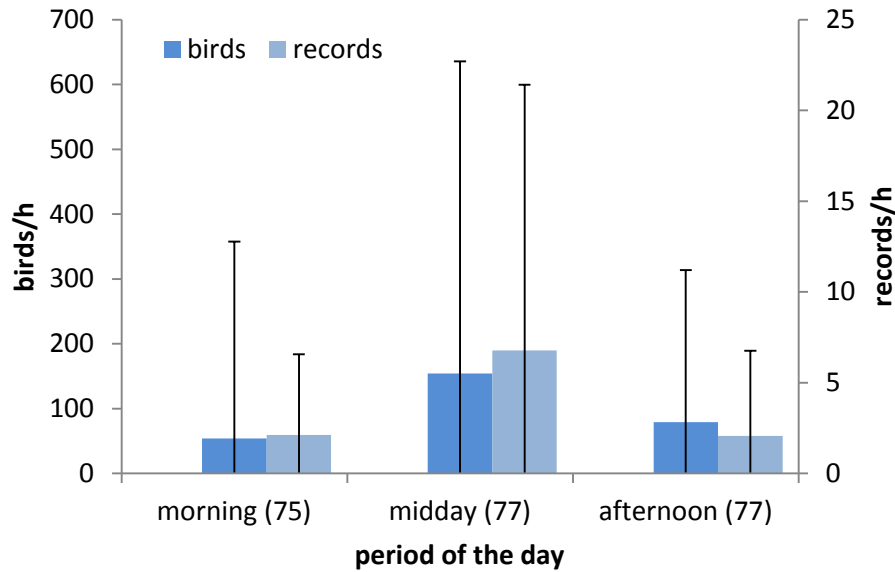

Figure 4.62: Average migratory activity (birds/h and records/h) at distances of up to 2.0 km to the observation sites during different periods of the day in spring 2016 (arithmetical mean and standard deviation; sample size (i.e. no. of observation days) for each period is given in brackets)

Altitude of Migrating Birds

In spring 2016 about 49 % of all birds and 64 % of all records were recorded at altitudes above 120 m (Table 4.35). About 38 % of all birds and 26 % of all records were - at least temporary - registered at altitudes from 30 to 120 m (roughly representing the rotor swept area of wind turbines). Only few birds/records migrated exclusively at altitudes below 30 m.

Table 4.35: Number of birds (above) and records (below) observed at distances of up to 2.0 km to the observation sites at different flight altitude classes registered in spring 2016

		flight altitude maximum (in m)		
		< 30 m	> 30 - 120 m	> 120 m
flight altitude minimum (in m)	birds			
	< 30 m	9,611	394	630
	> 30 - 120 m		14,606	12,536
> 120 m			36,534	
		flight altitude maximum (in m)		
		< 30 m	> 30 - 120 m	> 120 m
flight altitude minimum (in m)	records			
	< 30 m	270	44	5
	> 30 - 120 m		488	163
> 120 m			1,730	

Flight directions

As usual during the migration period in spring, the majority of birds (about 89 %) and records (about 81 %) migrated in southern directions. About 5 % headed for western and another 5 % of all birds for eastern directions.

Spatial Comparison of Migratory Activity

The analysis of migration rates (birds/h) during synchronous observation units at the two sites revealed no remarkable difference (Figure 4.63). However, migration rate (records/h) seemed to be slightly higher at site A. As the ACWA area is quite uniform, there are no remarkable topographic features which might affect the spatial distribution of bird migration in spring. To conclude, no clear spatial differentiation can be made when describing and assessing migratory activity in the area in spring.

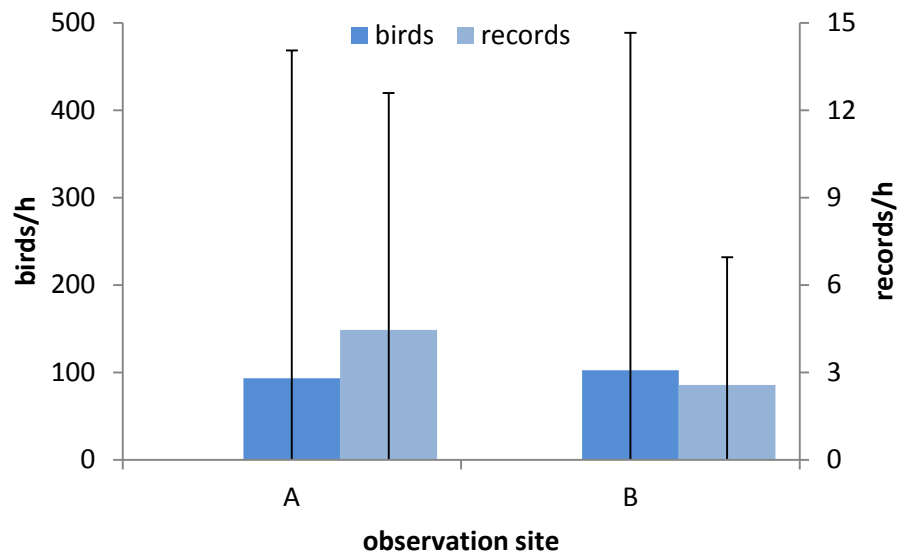

Figure 4.63: Comparison of migration rates during synchronized observation units at the two sites (A (n=154) and B (n=155)) in autumn 2015 (arithmetical mean and standard deviation over all observation units; sample size (i.e. no. of observation units) at each observation site is given in brackets)

Wind Speed and Wind Direction

During the survey in the ACWA area medium wind speeds were dominant in spring 2016 (Figure 4.64). In 75 % of all observation units wind was coming from northern direction.

The relation between migratory activity and the prevailing wind regime is very much in accordance with what was derived in the project area in spring 2016 (see Chapter 4.3.4.4.1) and can be summarized as follows:

- The majority of birds (and records) occurred in situations with medium and low wind speeds (Figure 4.65). The relative abundance of birds and records in low wind situations was clearly higher than could be expected from the portion of according observation units (Figure 4.66). In contrast, the portion of birds and records registered in high wind speed situations was very low.
- Most birds were registered in conditions with changing wind directions (Figure 4.65), much more than could be expected from the proportion of according observational units (see Figure 4.66). During only five observation units (on four days) a total of 21,595 birds were registered during changing wind conditions (representing 68 % of all birds). Thus, it becomes again apparent that single observation units had a high effect on the data set.
- A relevant number of birds and records were recorded in situations with southern wind directions, too (Figure 4.65). This result mainly refers to single observation units on four days with a high migratory activity (March 24th, April, 9th, 10th and 26th, see Table 4.34). The portions of birds/records that occurred in tailwind conditions were notably higher than could be expected from the portion of according observational units (Figure 4.66).

To conclude, the analysis revealed that spring migration in the ACWA area was relatively higher during favourable (with wind from southern directions or with low wind speeds) and lower in unfavourable conditions (i.e. (strong) northern wind). Nevertheless, a huge number of birds even migrated in headwind conditions as these were the most frequent conditions in spring 2016 and in general. Hence, migratory activity was not only affected by the wind regime, but also by other internal and external factors.

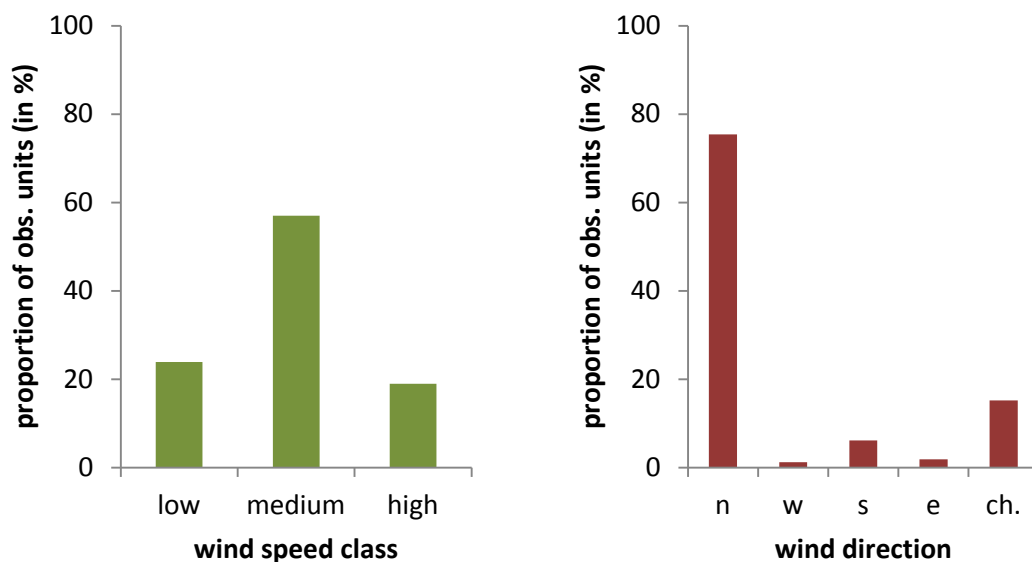

Figure 4.64: Wind speed (left) and wind direction (right) obtained in the ACWA area in spring 2016 (ch.= changing)

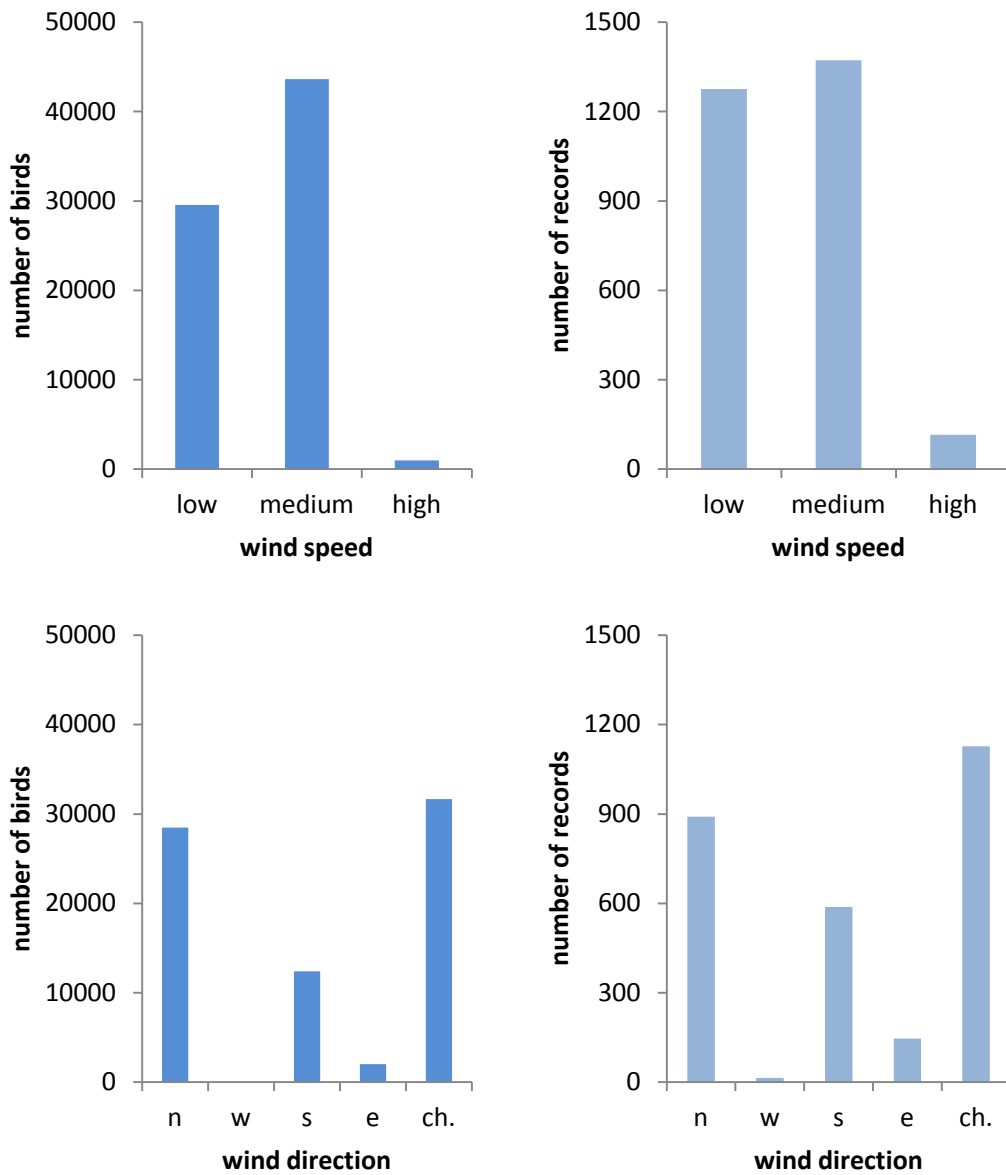

Figure 4.65: Total numbers of birds (left) and records (right) registered in the ACWA area during certain wind speed (above) and wind direction (below) conditions in spring 2016

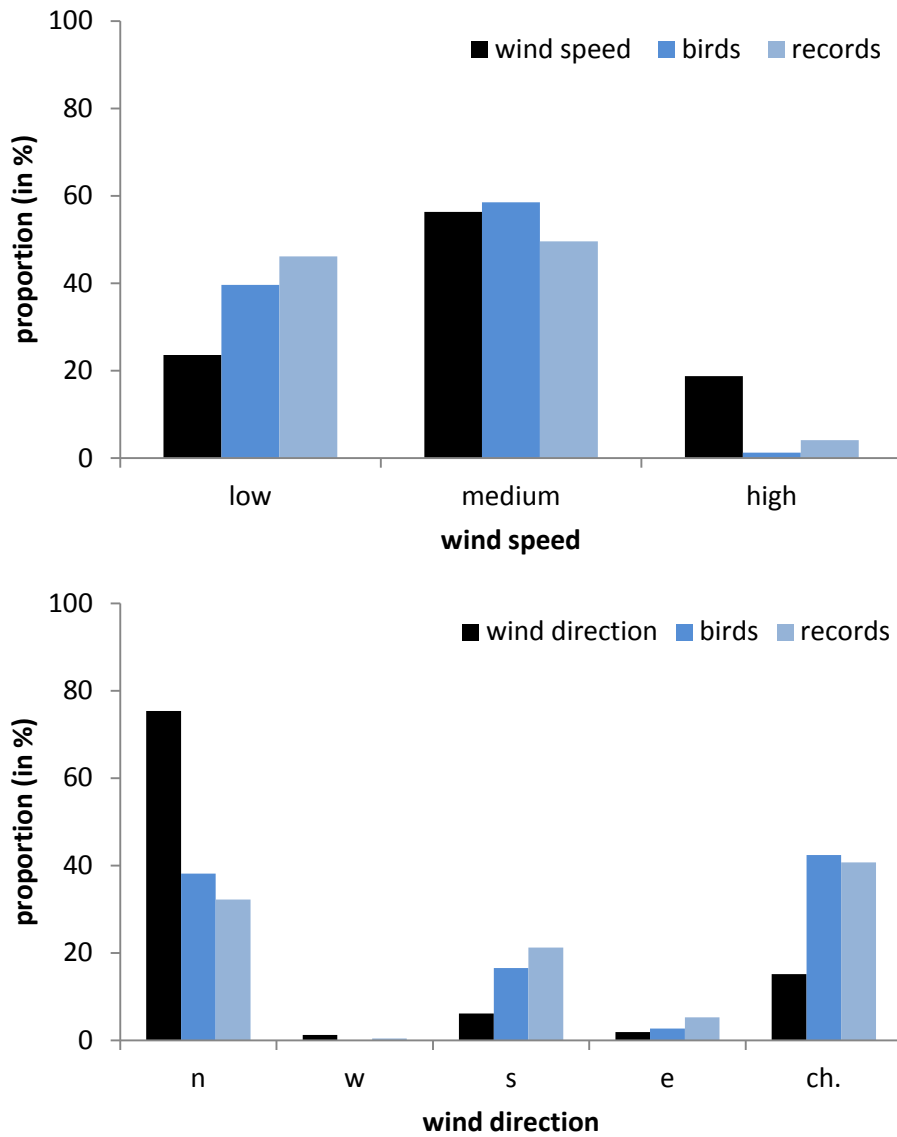

Figure 4.66: Proportion of observation units with different wind speed (above) and wind directions (below) and relative abundance (in %) of birds and records registered in spring 2016 during the according wind conditions

Other Observations of Migrating Birds

While driving through the ACWA area in spring 2016 few records of target species were obtained: Black Kite (2 birds) and Short-toed Snake Eagle (1 bird). In addition, migrating birds of species that are of minor relevance for the impact assessment were occasionally recorded during standardized observation units or by chance in the Alfanar area (see Table 4.36).

Table 4.36: Number of migrating birds of target species recorded by chance or of species that are of minor relevance for the impact assessment recorded in the ACWA area in spring 2016

species	scientific name	birds
Great Cormorant	<i>Phalacrocorax carbo</i>	1
Wood Sandpiper	<i>Tringa glareola</i>	8
Collared Pratincole	<i>Glareola pratincola</i>	9
Black-winged Pratincole	<i>Glareola nordmanni</i>	3
Wader	-	1
Gull-billed Tern	<i>Sterna nilotica</i>	2
Whiskered Tern	<i>Chlidonias hybridus</i>	42
Common Pigeon	<i>Columba livia</i>	1
European Turtle Dove	<i>Streptopelia turtur</i>	3
Dove spec.	-	1
Alpine Swift	<i>Tachymarptis melba</i>	2
Common Swift	<i>Apus apus</i>	109
Pallid Swift	<i>Apus pallidus</i>	15
European Bee-eater	<i>Merops apiaster</i>	812
Eurasian Hoopoe	<i>Upupa epops</i>	3
Greater Short-toed Lark	<i>Calandrella brachydactyla</i>	209
Lark spec.	-	9
Sand Martin	<i>Riparia riparia</i>	29
Eurasian Crag Martin	<i>Ptyonoprogne rupestris</i>	1
Barn Swallow	<i>Hirundo rustica</i>	770
Red-rumped Swallow	<i>Cecropis daurica</i>	67
Common House Martin	<i>Delichon urbica</i>	44
Willow Warbler	<i>Phylloscopus trochilus</i>	2
Warbler spec. (Phylloscopus)	<i>Phylloscopus spec.</i>	1
Lesser Whitethroat	<i>Sylvia curruca</i>	2
Black Redstart	<i>Phoenicurus ochruros</i>	1
White Wagtail	<i>Motacilla alba</i>	8
Yellow Wagtail	<i>Motacilla flava spec.</i>	4
Tawny Pipit	<i>Anthus campestris</i>	1
Tree Pipit	<i>Anthus trivialis</i>	9
Red-throated Pipit	<i>Anthus cervinus</i>	27
Pipit spec.	<i>Anthus spec.</i>	1
Passerine	-	4

4.3.5.4.5 Lekela Area in Spring 2016

Number of Migrating Birds, Species Composition and Flock Size

A total of 31,616 birds from 26 relevant species were observed in the Lekela wind farm area in spring 2016 (Table 4.37). White Stork, Steppe Buzzard, Steppe Eagle, Black Kite, and European Honey Buzzard were the most numerous species. These five species represent 91 % of all registered individuals (Table 4.37). About 45 % of all registered birds were White Storks, thus the White Stork was by far the most numerous species.

Although large flocks were rarely recorded, they have a strong effect on the data set. In total there was only one flock (0.1 % of all records) with more than 1,000 individuals, representing about 17 % of all migrating birds (Figure 4.67). In contrast, the fraction of birds migrating individually was about 40 % of all records yet about 2 % of all birds (Figure 4.67). Together, single birds and flocks with up to ten individuals constitute about 82 % of all records.

Overall 1,802 records (of an individual or a flock) were registered in Lekela wind farm area. Steppe Buzzard (34 %), Steppe Eagle (16 %), Black Kite (14 %) and European Honey Buzzard (4 %) were recorded most often. In contrast White Stork (less than 3 %) and Great White Pelican (less than 1 %) were recorded occasionally.

A total of 1,731 individuals of “Endangered” species and 22 individuals of “Vulnerable” species were recorded in the Lekela wind farm area in spring 2016 (see Table 4.37). In addition, 27 recorded individuals belong to species listed as “Near Threatened”. Note that there might have been further individuals of these or other species which might be found under Pallid / Montagu’s Harrier and Harrier as well as Eagle, Falcon or unidentified raptor.

Another 31,212 large soaring birds (291 records) were observed outside Lekela wind farm area, thereof: 24,426 White Storks, 2,397 Great White Pelicans, 1,300 Steppe Buzzards, 1,000 Levant Sparrowhawks and 493 Steppe Eagles.

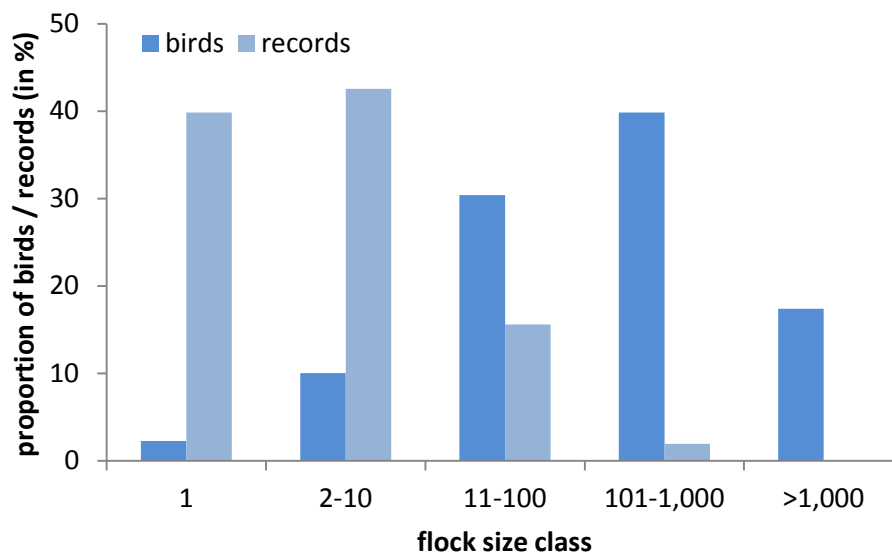

Figure 4.67: Relative abundance (proportion in %) of birds/records registered in different flock size classes in the Lekela wind farm area in spring 2016

Table 4.37: Number of birds and records registered in the Lekela area (in the proposed wind farm area, i.e. probably FiT-plot 2-5) in the study period (February 10th to May 15th) in spring 2016

species	scientific name	birds	records
Great White Pelican	<i>Pelecanus onocrotalus</i>	1,078	10
Black Stork	<i>Ciconia nigra</i>	286	19
White Stork	<i>Ciconia ciconia</i>	14,384	46
Osprey	<i>Pandion haliaetus</i>	5	5
European Honey Buzzard	<i>Pernis apivorus</i>	1,391	76
Black Kite	<i>Milvus migrans</i>	1,400	259
Egyptian Vulture	<i>Neophron percnopterus</i>	25	18
Short-toed Snake Eagle	<i>Circaetus gallicus</i>	307	116
Marsh Harrier	<i>Circus aeruginosus</i>	46	33
Pallid Harrier	<i>Circus macrourus</i>	26	20
Montagu's Harrier	<i>Circus pygargus</i>	38	22
Pallid / Montagu's Harrier	<i>Circus macrourus / pygargus</i>	1	1
Harrier	<i>Circus spec.</i>	10	10
Levant Sparrowhawk	<i>Accipiter brevipes</i>	73	9
Eurasian Sparrowhawk	<i>Accipiter nisus</i>	21	17
Steppe Buzzard	<i>Buteo buteo vulpinus</i>	10,004	615
Long-legged Buzzard	<i>Buteo rufinus</i>	26	19
Buzzard	<i>Buteo spec.</i>	73	9
Lesser Spotted Eagle	<i>Aquila pomarina</i>	119	31
Greater Spotted Eagle	<i>Aquila clanga</i>	11	2
Steppe Eagle	<i>Aquila nipalensis</i>	1,706	295
Eastern Imperial Eagle	<i>Aquila heliaca</i>	11	8
Booted Eagle	<i>Aquila pennata</i>	418	51
Eagle	-	22	7
Lesser Kestrel	<i>Falco naumanni</i>	1	1
Common Kestrel	<i>Falco tinnunculus</i>	88	80
Eleonora's Falcon	<i>Falco eleonora</i>	1	1
Sooty Falcon	<i>Falco concolor</i>	1	1
Lanner Falcon	<i>Falco biarmicus</i>	1	1
Peregrine Falcon	<i>Falco peregrinus</i>	1	1
Falcon	<i>Falco spec.</i>	11	10
unidentified raptor	-	5	5
Common Crane	<i>Grus grus</i>	26	4
total		31,616	1,802

Classification due to IUCN Red List of Threatened Birds: "Near Threatened". Species listed as "Least Concern" or not considered in the IUCN Red List are not colored.

Seasonal Distribution of Migratory Activity

In spring 2016 migratory activity was rather low during the first four weeks (i.e. up to March 8th). Subsequently, migration rates increased, peaked in week 9th (early April) and decreased afterwards (Figure 4.68). Most birds passed the study area between early of March and mid of April. Between March 9th and April 12th 87 % of all birds (and 79 % of all records) were registered.

Birds did not migrate regularly in equal numbers, but migration concentrated on few days or periods. During six days 23,271 birds were recorded in the Lekela area. Thus within about 6 % of all observation days 74 % of all birds were registered.

Those days with highest migratory activity in the Lekela wind farm area were partly in accordance with the “peak-“days in the areas surveyed in spring 2016. However, single “peak-“days in the other areas (March 24th, April 20th, May 8th) did not belong to those days with highest migratory activity in the Lekela wind farm area.

The number of records was high within certain days, too, and thus highly influenced the illustrated phenology. During twelve days (representing about 13 % of all observation days) about 63 % of all records were registered.

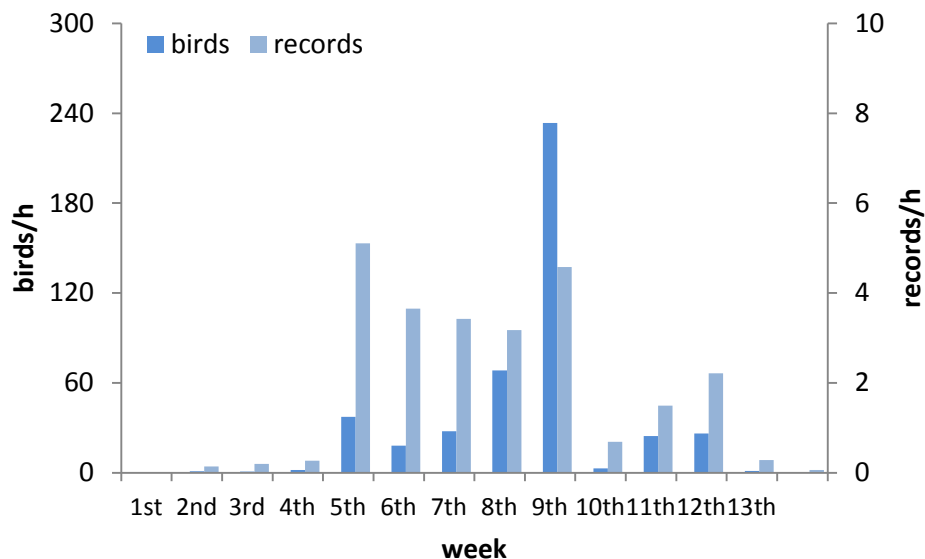

Figure 4.68: Migratory activity (birds/h and records/h) in different weeks in spring 2016 (only birds within Lekela wind farm area; to correct different observational time the number of birds/records was divided by observational time of the particular week; February 10th to February 16th)

Daily Distribution of Migratory Activity

The data from spring 2016 point towards a slightly higher migration rate during morning-midday, in comparison to midday-afternoon (Figure 4.69). However, in general migratory activity was highly variable within different periods of the day (see high standard deviation in Figure 4.69).

As mentioned above single events had a strong effect on the presented data. For instance, a single flock of 5,500 White Storks recorded on April 9th during morning leads to a (disproportionate high) increase of the arithmetical mean. To conclude, this pattern might not represent the migratory activity for the whole study period, as it might be caused by chance through single events, which had a strong effect on the data.

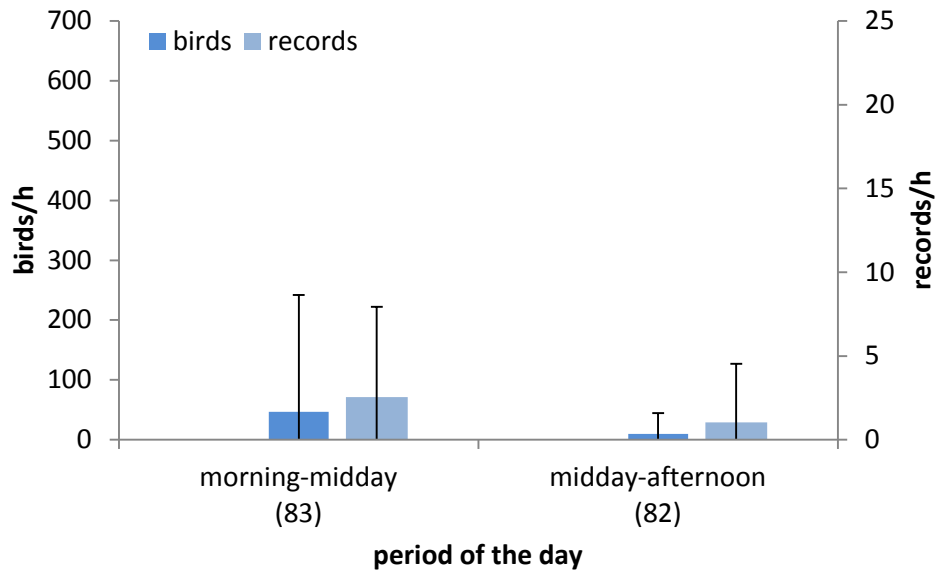

Figure 4.69: Average migratory activity (birds/h and records/h) in Lekela wind farm area during different periods of the day in spring 2016 (arithmetical mean and standard deviation; sample size (i.e. no. of observation days) for each period is given in brackets)

Altitude of Migrating Birds

During the study period in spring 2016 the majority of birds (and records) were registered at altitudes above 120 m (Figure 4.70). About 14 % of all birds and 18 % of all records were registered at altitudes from 30 to 120 m (roughly representing the rotor swept area of wind turbines). Only few birds/records migrated exclusively at altitudes below 30 m.

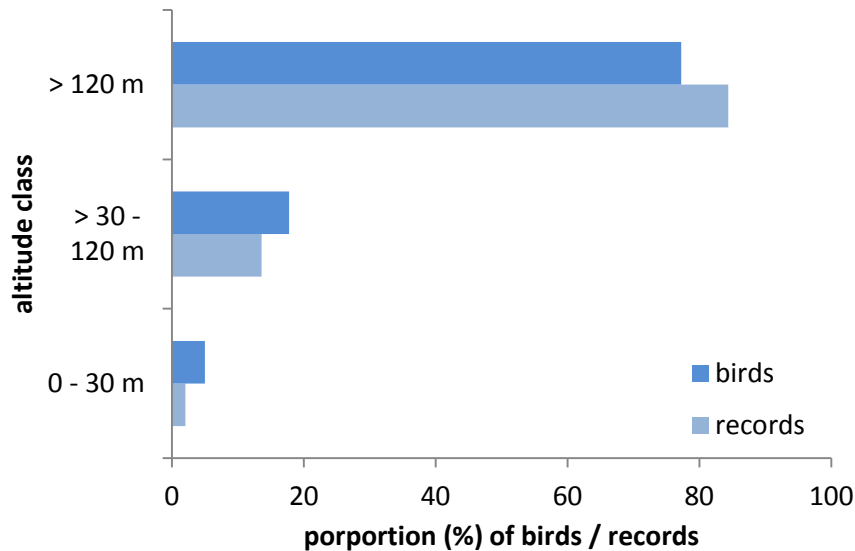

Figure 4.70: Relative abundance (%) of birds and records at different altitude classes in Lekela wind farm area in spring 2016

Flight directions

As usual during the migration period in spring, the majority of birds (about 80%) migrated in northern directions. About 9% and 8% of all birds headed for southern and western directions, respectively.

Spatial Comparison of Migratory Activity

Migratory activity at the two observation sites in Lekela wind farm did not differ significantly (Figure 4.71).

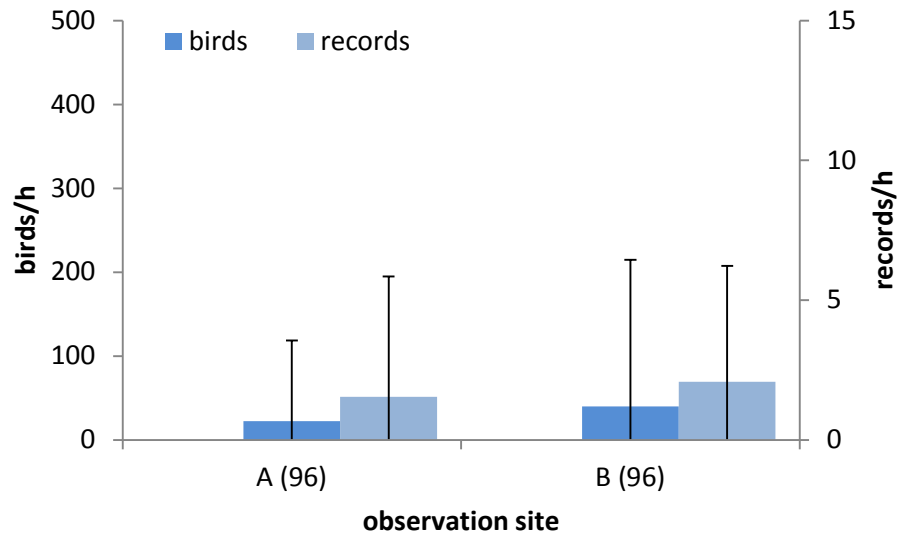

Figure 4.71: Comparison of migration rates obtained at the two observation sites in the Lekela wind farm area in spring 2016 (arithmetical mean and standard deviation over all observation units; sample size (i.e. no. of observation units) at each observation site is given in brackets)

Other Observations of Migrating Birds

Migrating birds of species that are of minor relevance for the impact assessment were occasionally recorded during standardized observation units or by chance in Lekela wind farm area (Table 4.38). No large soaring bird was recorded accidentally in the area in spring 2016.

Table 4.38: Number of migrating birds of species that are of minor relevance for the impact assessment recorded in Lekela wind farm area in spring 2016

species	scientific name	birds
Great Cormorant	<i>Phalacrocorax carbo</i>	2,933
Little Egret	<i>Egretta garzetta</i>	1
Wader	-	3
European Turtle Dove	<i>Streptopelia turtur</i>	5
Common Swift	<i>Apus apus</i>	20
Pallid Swift	<i>Apus pallidus</i>	1
Swift	<i>Apus spec.</i>	31
European Bee-eater	<i>Merops apiaster</i>	445
Greater Short-toed Lark	<i>Calandrella brachydactyla</i>	51
Sand Martin	<i>Riparia riparia</i>	24
Barn Swallow	<i>Hirundo rustica</i>	549
Red-rumped Swallow	<i>Cecropis daurica</i>	88
Common House Martin	<i>Delichon urbica</i>	139
Swallow	-	24

4.3.5.4.6 Assessment of the Importance of the Project Area for Spring Migration and Discussion

Qualitative Assessment

It is important to point out that the investigation conducted in the project area in spring 2016 did not fully cover main migration periods of large soaring species. Common Crane and Steppe Eagle and partly also White Stork are known to migrate in February and March. Hence, numbers of birds of these species might have already passed the area before the start of the investigation. Nevertheless, the investigation undertaken in 2017 comprised the full migration period and can be used to assess the importance of the project area for large soaring birds during spring migration. In addition, other surveys conducted in parts of the project area (Alfanar, ACWA, Lekela) in spring 2016 can give valuable support to the assessment.

A very high number (147,611) of birds of target species have been recorded during 1,351.1 hours of standardized observations in the study area in spring 2017. Though migration of relevant species was low during some periods, a very high migratory activity was obtained on single days. Relevant numbers of “Endangered” or “Vulnerable” species occurred in the study area, in particular Steppe Eagle with 4,740 individuals. Hence, the study area (and thus the project area, too) is located in or near an important migration route for large soaring birds in spring.

It is well known that the Red Sea coast, in particular the area around Gabel al Zayt, located about 70 km southeast of the project area, is a major bottleneck for large soaring birds that breed in Europe, the Middle East and Asia but winter in tropical and southern Africa. However, in accordance with previous findings (Bergen & Gaedicke 2013) the current investigation provides proof that at least a major share of Great White Pelican, White Storks, European Honey Buzzards and Levant Sparrowhawks apparently do not cross the Red Sea at Gabal el Zayt in spring, but migrate over the desert plains following the Red Sea coast further north(west) (most probably up to Suez). In addition, this investigation reveals that other species, like Steppe Buzzard, Black Kite or Steppe Eagle, that were believed to follow the Red Sea Mountains north to Suez town, apparently also migrate in nameable numbers over the desert plains of the western Red Sea coast. The findings of the studies conducted in the Alfanar area, the ACWA area, the Lekela area and the project area in spring 2016 very much foster this conclusion.

Based on these considerations the project area is clearly of high importance for large soaring birds in spring.

Quantitative Assessment by Comparison of Migration Rates

As given above (Chapter 4.3.4.3.4), a comparison of migration rates seems to be another useful way to assess the importance of an area for bird migration, though the derived conclusions have to be treated carefully.

Average migration rates (related to an area of about 20 km², i.e. circle with a radius of 2.5 km) obtained in the project area in spring 2016 and 2017 were 126.1 and 109.3 birds/h and 2.9 and 2.7 records/h, respectively (Table 4.39). Comparable migration rates were recorded in the Alfanar and the ACWA area, whereas the value in the Lekela area was clearly lower (note that the precise area to which the Lekela data is related remains unknown). According to studies previously conducted at the western coast of the Red Sea migratory activity in spring ranged between 82.6 to 213.1 birds/h and 4.3 to 8.3 records/h (again related to about 20 km²; Table 3.39). These studies were carried out on the desert plains west and northwest of Gabal el Zayt, i.e. mainly south and southeast of the project area. The “300 km² NW of Ras Ghareb” area is located directly adjacent to the (south)west of the project area. Thus, migratory activity in the project area obviously reaches a comparable dimension as obtained in areas further south. Based on these findings it is most likely that the project area is of high importance for large soaring birds in spring. The results clearly show

that nameable numbers (temporarily extremely high numbers) of large soaring birds occur in the project area.

Table 4.39: Migration rates recorded during spring in different areas at the Red Sea coast (data from Bergen 2009, Bergen & Gaedicke 2013, ecoda 2007, 2011, 2016a, b, unpublished data)

location	year	migration rate birds/h	migration rate records/h
Ras Gemsa to Ras Shukeir	2007	157.7	4.3
Orange Zone (Gabel el Zayt)	2009	82.6	5.2
200 km ² area SW of Ras Ghareb	2010	213.3	8.3
300 km ² area NW of Ras Ghareb	2013	191.6	5.5
Alfanar area	2016	100.0	2.6
ACWA area**	2016	96.6	3.6
Lekela area***	2016	32.9	1.9
project area 2016*	2016	126.1	2.9
project area 2017	2017	109.3	2.7

* - migration period not fully covered

** - only 2.0 km from observation sites (all other cases: 2.5 km)

*** - "wind farm area" not precisely known

Assessment by Criteria developed by BirdLife International

As given above (Chapter 4.3.4.3.4), BirdLife International developed two criteria for assessing the importance of a site.

Applying these criteria on the current data (firstly without any consideration of corrections factors and other aspects) it becomes obvious that the project area clearly meets both criteria:

- During standardized field observations in spring 2017 a total of 147,611 birds of target species were recorded at the 14 observation sites within the project area. This data clearly demonstrate that the project area meets the 1st criterion developed by BirdLife International ("...at least 20,000 storks, raptors..."). This conclusion is not only valid for the whole project area, but also for single observation sites and FiT-plots, e.g.:
 - i. Observation site 6F (2017, one team): 33,925 birds of target species were recorded
 - ii. Alfanar area (2016, one team): 38,502 birds of target species were recorded
 - iii. ACWA area (2016, two teams): 74,579 birds of target species were recorded
 - iv. Lekela area (2016, two teams): 31,616 birds of target species were recorded
- As given in Table 4.40, more than 12 % of the flyway population of Steppe Eagle, a species classified by IUCN as "Endangered", and of White Stork migrated through the project area in spring 2017. In addition, more than 1 % of the flyway population of seven other target species were recorded in the project area clearly pointing at the outstanding importance of the area for large soaring birds during spring migration.

Furthermore, the results of the other surveys clearly show that the importance does not refer to the whole project, but also to single smaller parts of it and to single FiT-plots: The 1%-criterion was met in the Alfanar area (for four species), in the ACWA area (for nine species) and in the Lekela area for seven species (see Tables 4.42 to 4.44). Hence, the importance of these areas for spring migration of large soaring birds has to be assessed as high, too.

Table 4.40: Number of birds recorded in the project area in spring 2017 and according proportion (in %) of the flyway population (only species that meet the 1 %-criteria)

species	scientific name	number in project area 2017	% of flyway pop.
Great White Pelican	<i>Pelecanus onocrotalus</i>	770	1.1
White Stork	<i>Ciconia ciconia</i>	93,199	12.4-23.3
Black Kite	<i>Milvus migrans</i>	4,077	3.1
Egyptian Vulture	<i>Neophron percnopterus</i>	56	1.2
Short-toed Snake Eagle	<i>Circaetus gallicus</i>	472	5.4
Levant Sparrowhawk	<i>Accipiter brevipes</i>	822	1.1
Steppe Buzzard	<i>Buteo buteo vulpinus</i>	32,516	2.6
Steppe Eagle	<i>Aquila nipalensis</i>	4,740	12.6
Booted Eagle	<i>Aquila pennata</i>	153	3.1

Data on flyway population are taken from Lesham & Yom-Tov (1996), Hilgerloh (2009) and Carlbro (2009) after double-checking and comparison with other available sources. Due to the great difference between the size of the flyway population of the White Stork in Hilgerloh (2009) and Carlbro (2009) both proportions are given.

Table 4.41: Number of birds recorded in the project area in spring 2016 and according proportion (in %) of the flyway population (only species that meet the 1 %-criteria; note that only the 2nd half of the main migration period was covered by the survey)

species	scientific name	number in project area 2016	% of flyway pop.
Great White Pelican	<i>Pelecanus onocrotalus</i>	3,015	4.3
White Stork	<i>Ciconia ciconia</i>	45,559	6.1 – 11.4
European Honey Buzzard	<i>Pernis apivorus</i>	10,622	1.1
Egyptian Vulture	<i>Neophron percnopterus</i>	78	1.7
Short-toed Snake Eagle	<i>Circaetus gallicus</i>	100	1.1
Booted Eagle	<i>Aquila pennata</i>	81	1.6

For data reference see Table 4.40

Table 4.42: Number of birds recorded in the Alfanar area in spring 2016 and according proportion (in %) of the flyway population (only species that meet the 1 %-criteria)

species	scientific name	number in Alfanar area 2016	% of flyway pop.
Great White Pelican	<i>Pelecanus onocrotalus</i>	1,577	2.3
White Stork	<i>Ciconia ciconia</i>	22,455	3.0-5.6
Black Kite	<i>Milvus migrans</i>	1,927	1.5
Steppe Eagle	<i>Aquila nipalensis</i>	1,433	3.8

For data reference see Table 4.40

Table 4.43: Number of birds recorded in the ACWA area in spring 2016 and according proportion (in %) of the flyway population (only species that meet the 1 %-criteria)

species	scientific name	number in ACWA area 2016	% of flyway pop.
Great White Pelican	<i>Pelecanus onocrotalus</i>	6,242	8.9
Black Stork	<i>Ciconia nigra</i>	385	1.0
White Stork	<i>Ciconia ciconia</i>	43,450	5.8-10.9
Black Kite	<i>Milvus migrans</i>	1,859	1.4
Egyptian Vulture	<i>Neophron percnopterus</i>	50	1.1
Short-toed Snake Eagle	<i>Circaetus gallicus</i>	209	2.4
Pallid Harrier	<i>Circus macrourus</i>	18	1.2
Steppe Eagle	<i>Aquila nipalensis</i>	2,349	6.3
Booted Eagle	<i>Aquila pennata</i>	130	2.6

For data reference see Table 4.40

Table 4.44: Number of birds recorded in the Lekela area in spring 2016 and according proportion (in %) of the flyway population (only species that meet the 1 %-criteria)

species	scientific name	number in Lekela area 2016	% of flyway pop.
Great White Pelican	<i>Pelecanus onocrotalus</i>	1,078	1.5
White Stork	<i>Ciconia ciconia</i>	14,384	1.9-3.6
Black Kite	<i>Milvus migrans</i>	1,400	1.1
Short-toed Snake Eagle	<i>Circaetus gallicus</i>	307	3.5
Pallid Harrier	<i>Circus macrourus</i>	26	1.7
Steppe Eagle	<i>Aquila nipalensis</i>	1,706	4.5
Booted Eagle	<i>Aquila pennata</i>	418	8.4

For data reference see Table 4.40

It has to be clearly pointed out that the spatial differences in the numbers of birds and, thus, in the magnitude of the flyway populations are not characteristics of the particular areas, but are caused by the typical migratory activity at the Red Sea coast which is highly variable in time and space. Moreover the differences refer also to the particular effort (e.g. one team-approach in the Alfanar area vs. two team-approach in the ACWA area) and to the overall observation time that was spent during each survey. When considering the effort by comparing the migration rates (birds/h and records/h) no significant differences in migratory activity was found in the areas and at the observation sites. Migratory activity at all sites was highly variable and strongly affected by few large flocks which are rare events and can be recorded at every individual observation site. The results obtained in spring 2016 and 2017 do not support the assumption of the existence of preferred flight paths that are regularly (i.e. every spring) used or of certain areas with lower migratory activity. There are no remarkable topographic features which affect the spatial distribution of large soaring birds over the desert coastal plains northwest of Ras Ghareb in spring. This is very much in accordance with the findings obtained in the 300 km² area in spring 2013 which have also demonstrated that there exist no areas in which migration is concentrated. The spatial distribution of large soaring birds over the desert plains is affected by the current environmental situation (e.g. location of thermal uplifts, wind speed and direction), time of the year and internal factors that influence a bird's decision (e.g. on whether crossing the Red Sea or not). As a consequence, spatial

distribution is not a constant pattern that can be observed every spring. Consequently, no spatial differentiation can be made when describing and assessing migratory activity in the project area in spring. Hence, the importance of each individual FiT-plot for spring migration of large soaring birds has to be assessed as high, too (especially if it is considered that the recorded numbers present only a sample of the overall bird migration).

Note that this might be different further north where the Red Sea Mountains approach the Red Sea coast and form a natural obstacle for migrating birds with an altitude of about 500 to 1.000 m a.s.l. at distances of 10 to 15 km to the coastline. To gain a more comprehensive understanding on bird migration at the western coast of the Red Sea additional information on migratory activity in the Red Sea Mountains (west of the project area) and information on flight paths of birds/flocks over larger distances (e.g. tracked by GPS/GSM technology) would be very helpful.

When applying the 1 %-criterion based on the recorded numbers (as given in Tables 4.40 to 4.44), it is important to consider that the results obtained in the surveys present only a sample of the overall bird migration of target species in the individual area. For several reasons (already mentioned in Chapter 4.3.4.3.4) the real numbers of large soaring birds that migrated through the areas in spring 2016 and 2017, respectively, were without any doubt higher than the numbers obtained during the surveys. So, it might initially seem to be reasonable to correct the obtained data set and to calculate a real number of birds, e.g. by extrapolating the data applying correction factors that are based on certain assumptions. An exemplary approach is outlined in the following:

1. Definition of a main species-specific migration period (numbers of days in which 90 % of all birds were recorded).
2. Calculation of a species-specific average migration rate (birds/h) by considering the number of birds of the species and the observational time (both restricted to the main migration period of the species).
3. Consideration of daily observation time: Calculation of the species-specific migration rate (birds/h) and subsequently calculation of the total number of migrating birds per day assuming an average daily migration period of 10 hours.
4. Consideration of missed birds by definition of a correction factor.
5. Consideration of the monitored area by definition of a correction factor.

Applying this approach to the White Stork, the most numerous species during spring migration at the Red Sea coast, a total of 53,563 birds are believed to have crossed the Alfanar area in spring 2016, representing about 9.3 % of the flyway population instead of 3.0 to 5.6 % as calculated by the observed numbers (see Table 4.45). Similar results are gained for the ACWA area (sites A and B) and the Lekela area (site B), because migration rates at these site were comparable (between 112 and 120 birds/h; Table 4.43). In contrast, migration rate at site A in the Lekela area was remarkably lower, leading to an estimated flyway population of 2.1 %, i.e. only about a quarter of that estimated for site B. However, the difference in the recorded number of White Storks at the two sites was about 7,500 birds (see Table 4.45). Bearing in mind that this number can be easily achieved by two or three flocks, it becomes apparent that the results obtained by the given approach are not reliable. Two or three flocks might strongly affect the extrapolation and the derived conclusion. Thus, the explanatory power of such estimates is believed to be very weak.

Table 4.45: Exemplary approach for estimating the real numbers of White Stork migrated through an area in spring 2016 (based on the numbers recorded in different areas and on certain assumptions; note that the explanatory power of the results is believed to be very weak, as given in the text)

Area	Alfanar		ACWA		Lekela	
Year	2016	2016	2016	2016	2016	2016
Observation site	1	A	B	A	B	
Main migration period (i.e. in which 90% of all birds were recorded)	24/3 - 3/5	24/3 - 2/5	24/3 - 2/5	9/4 - 26/4	9/4 - 26/4	
Main migration period (no. of days)	41	40	40	18	18	
Total number of birds recorded at an observation site in main migration period	20,784	19,651	20,696	2,831	10,364	
Observation time during main migration period (in hours)	175	170	172	92	93	
Average migration rate during main migration period (birds/h)	119	116	120	31	112	
Total numbers of birds per day (i.e. within 10 hours)	1,188	1,156	1,203	308	1,117	
Total numbers of birds during main migration period	48,694	46,238	48,130	5,539	20,113	
Correction factor I (10 % of White Storks missed)	53,563	50,861	52,943	6,093	22,125	
Correction factor II (portion of the project area that was monitored)	100%	100%	100%	50%	50%	
Estimated total numbers of birds during spring migration	53,563	50,861	52,943	12,186	44,250	
Flyway Population (mean between highest and lowest estimate)	575,000	575,000	575,000	575,000	575,000	
Portion of the Flyway Population	9.3	8.8	9.2	2.1	7.7	

This becomes even more obvious when considering the estimates for White Storks that migrated through the project area in spring 2017 (Table 4.46): Whereas the calculation based on the data obtained at observation site 1 leads to a value of about 24 % of the flyway population, the calculation based on site 14 leads the unreasonable value of 484 % (for the whole project area). This meaningless result is mainly caused by correction factor II considering the monitored area in relation to the whole project area. An important conclusion that can be derived by this exemplary approach is that one cannot quantify migratory activity within a large area by the data of a rather small area.

Even when applying the approach to individual observation sites (disregarding correction factor II) the calculated portions of the flyway population largely differ among sites, i.e. from 1.7 % for observation site 1 to 34.1 % for site 14. Still the difference probably caused by few large flocks is extremely high and the accuracy of these estimates is believed to be very low. The main reason for this is probably that an important precondition due to the temporal distribution of migration is not met: migratory activity is not constant over time as assumed within the extrapolation. The same is valid for the spatial distribution of migrating birds. Large soaring birds concentrate in areas where thermal uplifts occur and, thus, often migrate in loose flocks, like raptors, or dense flocks, as typical for Great White Pelican or White Stork. So, migratory activity within a large area is not equally distributed.

To conclude, a species-specific extrapolation of the overall number of birds that likely migrated through the study area during a full migration season is not believed to come to reasonable results.

The explanatory power of results gained by this approach seems to be very weak. Hence, such extrapolations likely lead to wrong conclusions. For that reason no further attempt was undertaken to estimate the overall numbers of target species.

Moreover, such extrapolations are not necessary in the context of this survey, because the obtained data set is absolutely sufficient to assess the species-specific importance of the area for migration of large soaring birds.

Table 4.46: Exemplary approach for estimating the real numbers of White Stork migrated through an area in spring 2017 (based on the numbers recorded at different observation sites in the project area and on certain assumptions; note that the explanatory power of the results is believed to be very weak, as given in the text)

Area	RCREEE				
	2017				
Year					
Observation Site	1	6F	8F	12	14
Main migration period (i.e. in which 90% of all birds were recorded)	30/3 - 6/5				
Main migration period (no. of days)	38				
Total number of birds recorded at an observation site in main migration period	751	25,850	3,871	1,500	14,068
Observation time during main migration period (in hours)	32	92	30	31	30
Average migration rate during main migration period (birds/h)	23	281	129	49	469
Total numbers of birds per day (i.e. within 10 hours)	235	2,810	1,290	490	4,689
Total numbers of birds during main migration period	8,918	106,772	49,033	18,638	178,195
Correction factor I (10 % of White Storks missed)	9,810	117,449	53,936	20,501	196,014
Correction factor II (portion of the project area that was monitored)	7%	7%	7%	7%	7%
Estimated total numbers of birds during spring migration	139,301	1,667,775	765,890	291,119	2,783,401
Flyway Population (mean between highest and lowest estimate)	575,000	575,000	575,000	575,000	575,000
Portion of the Flyway Population	24.2	290.0	133.2	50.6	484.1
Portion of the Flyway Population (without correction factor II)	1.7	20.4	9.4	3.6	34.1

4.3.5.5 Results on Roosting Birds

4.3.5.5.1 Autumn

Single roosting individuals of 15 different species were recorded in the project area in autumn 2016 (Table 4.47). There was no species that appeared frequently or in high numbers in the project area. There existed no important roosting site for birds in autumn 2016.

These findings are in accordance with the results obtained in the Alfanar area and in the ACWA area in autumn 2015. There was only one remarkable observation of roosting birds of a target species: On September 10th, 2015, a flock of 75 Great White Pelicans roosted in the ACWA area in the early morning for about 53 min before taking off for migration. These birds probably spent a single night in the desert.

Table 4.47: Number of roosting birds recorded in the project area in autumn 2016

species	scientific name	no. of birds
Eurasian Bittern	<i>Botaurus stellaris</i>	2
European Turtle Dove	<i>Streptopelia turtur</i>	2
Great Grey Shrike	<i>Lanius excubitor</i>	2
Masked Shrike	<i>Lanius nubicus</i>	1
Warbler	<i>Phylloscopus spec.</i>	2
Eurasian Blackcap	<i>Sylvia atricapilla</i>	2
Rüppell's Warbler	<i>Sylvia rueppelli</i>	5
Common Redstart	<i>Phoenicurus phoenicurus</i>	5
Hooded Wheatear	<i>Oenanthe monacha</i>	1
Black-eared Wheatear	<i>Oenanthe hispanica</i>	2
Desert Wheatear	<i>Oenanthe deserti</i>	1
Isabelline Wheatear	<i>Oenanthe isabellina</i>	1
White Wagtail	<i>Motacilla alba</i>	2
Spanish Sparrow	<i>Passer hispaniolensis</i>	1
Meadow Pipit	<i>Anthus pratensis</i>	1

4.3.5.5.2 Spring

The number of birds roosting in the project area was very low during the study period in spring 2016 (Table 4.48). There was one remarkable observation of roosting birds of a target species: On May 1st, 2016, a flock of 2,000 Great White Pelicans roosted northeast of observation site 12 in the early morning for about 20 min before taking off for migration. These birds probably spent a single night in the desert. In addition, once a Levant Sparrowhawk roosted near observation site 6F. There was no species that appeared regularly in the project area. There existed no important roosting site for birds in spring 2016.

In spring 2017 a total of 383 birds from at least 21 species appeared in the project area, thereof 278 birds of target species (Table 4.49):

- On April 24th two small flocks (4 and 9 individuals) of White Stork roosted between observation sites 6F and 8F in the early morning. These birds probably spent a single night in the desert.

Table 4.48: Number of roosting birds recorded in the project area in spring 2016

species	scientific name	no. of birds
Great White Pelican*	<i>Pelecanus onocrotalus</i>	2,000
Levant Sparrowhawk	<i>Accipiter brevipes</i>	1
Common Kestrel	<i>Falco tinnunculus</i>	1
European Turtle Dove	<i>Streptopelia turtur</i>	2
Masked Shrike	<i>Lanius nubicus</i>	1
Woodchat Shrike	<i>Lanius senator</i>	1
Eurasian Reed Warbler	<i>Acrocephalus scirpaceus</i>	2
Great Reed Warbler	<i>Acrocephalus arundinaceus</i>	1
Lesser Whitethroat	<i>Sylvia curruca</i>	1
Collared Flycatcher	<i>Ficedula albicollis</i>	1
Northern Wheatear	<i>Oenanthe oenanthe</i>	2

* for about 20 min. in the early morning

Table 4.49: Number of roosting birds recorded in the project area in spring 2017

species	scientific name	no. of birds
White Stork	<i>Ciconia ciconia</i>	13
Black Kite	<i>Milvus migrans</i>	1
Short-toed Snake Eagle	<i>Circaetus gallicus</i>	1
Steppe Buzzard	<i>Buteo buteo vulpinus</i>	240
Lesser Spotted Eagle	<i>Aquila pomarina</i>	1
Steppe Eagle	<i>Aquila nipalensis</i>	18
Common Kestrel	<i>Falco tinnunculus</i>	4
Cream-coloured Courser	<i>Cursorius cursor</i>	2
European Turtle Dove	<i>Streptopelia turtur</i>	2
Laughing Dove	<i>Streptopelia senegalensis</i>	5
Eurasian Hoopoe	<i>Upupa epops</i>	5
Greater Short-toed Lark	<i>Calandrella brachydactyla</i>	55
Savi's Warbler	<i>Locustella luscinioides</i>	2
Eurasian Reed Warbler	<i>Acrocephalus scirpaceus</i>	1
Eastern Olivaceous Warbler	<i>Hippolais pallida</i>	1
Eurasian Blackcap	<i>Sylvia atricapilla</i>	1
Lesser Whitethroat	<i>Sylvia curruca</i>	16
European Pied Flycatcher	<i>Ficedula hypoleuca</i>	1
Northern Wheatear	<i>Oenanthe oenanthe</i>	4
Wheatear spec.	<i>Oenanthe spec.</i>	1
White Wagtail	<i>Motacilla alba</i>	6
Yellow Wagtail	<i>Motacilla flava spec.</i>	3

- On March 18th 228 Steppe Buzzards roosted on the ground at different locations in the project area during a sand storm. Single roosting Steppe Buzzards were recorded on March 11th and April 12th, too (see Figure 4.72).
- On March 18th 14 Steppe Eagles roosted on the ground in the project area during a sand storm. Single roosting Steppe Eagles were recorded on March 11th, March 19th, and April 30th, too.
- A single individual of Black Kite, Short-toed Snake Eagle, Lesser Spotted Eagle was recorded once roosting on the ground.
- A single roosting individual of Common Kestrel was recorded four times in spring 2017.

Most of non-target species recorded in spring 2017 were songbirds (passerines). There was no species that appeared regularly in the project area. There existed no important roosting site for birds in spring 2017.

These findings are in accordance with the results obtained in the Alfanar area and in the ACWA area in spring 2016: Roosting Great White Pelicans (a flock of 160 birds) were observed in the ACWA area once. Single roosting individuals of Storks and birds of prey were rarely found in the Alfanar area and the ACWA area. Steppe Buzzard occurred most frequently: 8 records with a total of 61 roosting birds.



Figure 4.72: A single Steppe Buzzard (left) and a flock of Great White Pelican (right) roosting in the desert at the Red Sea coast (outside the project area) in spring 2017

4.3.5.5.3 Final Conclusions

The results of the available investigations consistently reveal that target species rarely use the project area as a roosting habitat. Considering the high numbers of birds that cross the area during spring migration season (147,611 birds were recorded in spring 2017), the number of roosting birds observed in the project area was very low. Most birds were recorded in the early morning clearly indicating that these birds obviously spend a single night in the desert before continuing migration. In times of bad weather conditions (e.g. during sand storms which rarely occur) target species might stop migration and go down on the ground even during daytime. There are no spots that were preferred by target species as a roosting site. In fact, the project area does not offer special habitat features (like sebkhas) that are particularly suitable for large soaring birds. To conclude, the importance of the project area as a roosting site for large soaring birds is low.

Most non-target species (predominately songbirds) were found in the wadis that hold small patches of vegetation which offer shelter against the sun during the day. Those wadis can be regarded as a suitable roosting site for small songbirds. Nevertheless, the number of recorded birds was rather small. Hence, the importance of the project area as a roosting site for non-target species is low.

The project area does not hold any important roosting site for birds.

4.3.5.6 Results on Local Birds

4.3.5.6.1 Autumn

During the survey in autumn 2016 single local species belonging to the typical desert fauna were recorded in the project area (Table 4.50). The local bird community was poor in species and bird density was very low. Crowned Sandgrouse, Spotted Sandgrouse and Brown-necked Raven were the most numerous species. Three target species that were regarded as local birds due to their behaviour occurred in the project area:

- The area was occasionally visited by Common Kestrels probably breeding outside the project area (e.g. at Ras Ghareb, at poles of overhead powerlines or at cliffs in rocky areas).
- The area was rarely visited by Sooty Falcons. The next known breeding sites of this species exist on islands in the Red Sea. There might be further suitable breeding sites in the Red Sea Mountains. Within the project area and its surrounding no potential breeding site exists.
- Barbary Falcon was recorded in the project area only once.

These results are in accordance with the findings obtained in the Alfanar area and in the ACWA area in autumn 2015.

Table 4.50: Number of local birds recorded in the project area in autumn 2016

species	scientific name	no. of birds
Common Kestrel	<i>Falco tinnunculus</i>	9
Sooty Falcon	<i>Falco concolor</i>	3
Barbary Falcon	<i>Falco pelegrinoides</i>	1
Spotted Sandgrouse	<i>Pterocles senegallus</i>	24
Crowned Sandgrouse	<i>Pterocles coronatus</i>	37
Sandgrouse spec.	<i>Pterocles spec.</i>	22
Brown-necked Raven	<i>Corvus ruficollis</i>	93
Desert Lark	<i>Ammomanes deserti</i>	19
Greater Hoopoe-Lark	<i>Alaemon alaudipes</i>	1
House Sparrow	<i>Passer domesticus</i>	3

4.3.5.6.2 Spring

The number of species of local birds recorded during the study period in spring 2016 was very low (Table 4.51). No important breeding site was identified. Spotted Sandgrouse and Desert Lark are regarded as breeding species in the project area. Common Kestrel, Crowned Sandgrouse and Brown-necked Raven might breed outside the study area, but visit it temporarily for foraging.

Table 4.51: Number of local birds recorded in the study area in spring 2016

species	scientific name	no. of birds
Common Kestrel	<i>Falco tinnunculus</i>	4
Spotted Sandgrouse	<i>Pterocles senegallus</i>	139
Crowned Sandgrouse	<i>Pterocles coronatus</i>	17
Sandgrouse spec.	<i>Pterocles spec.</i>	2
Brown-necked Raven	<i>Corvus ruficollis</i>	26
Desert Lark	<i>Ammomanes deserti</i>	1

During the survey in spring 2017 single local species belonging to the typical desert fauna were recorded in the project area (Table 4.52). The local bird community was poor in species and bird density was very low. A breeding site of a pair of Brown-necked Raven was found at a cliff west of observation site 1 (see Figure 4.73). Spotted Sandgrouse, Brown-necked Raven, Desert Lark and Greater Short-toed Lark are regarded as breeding species in the project area. All other species might breed outside the project area, but visit it temporarily for foraging or simply rarely cross it.

Table 4.52: Number of local birds recorded in the project area in spring 2017

species	scientific name	no. of birds
Common Kestrel	<i>Falco tinnunculus</i>	16
Cream-coloured Courser	<i>Cursorius cursor</i>	2
White-cheeked Tern	<i>Sterna repressa</i>	3
Spotted Sandgrouse	<i>Pterocles senegallus</i>	497
Crowned Sandgrouse	<i>Pterocles coronatus</i>	40
Sandgrouse spec.	<i>Pterocles spec.</i>	263
Common Pigeon	<i>Columba livia</i>	3
European Turtle Dove	<i>Streptopelia turtur</i>	1
Laughing Dove	<i>Streptopelia senegalensis</i>	1
Brown-necked Raven	<i>Corvus ruficollis</i>	93
Desert Lark	<i>Ammomanes deserti</i>	90
Greater Hoopoe-Lark	<i>Alaemon alaudipes</i>	2
Greater Short-toed Lark	<i>Calandrella brachydactyla</i>	543



Figure 4.73: Breeding site of a pair of Brown-necked Raven at a cliff west of observation site 1

4.3.5.6.3 Final Conclusions

Only very few species inhabit the project area and use it as a breeding site (e.g. Spotted Sandgrouse and Larks). Due to the hyper-arid climate, the harsh wind conditions and - probably most important - the lack of vegetation bird density of breeding species is very low. Other species visit the project area occasionally and use it as a hunting (e.g. Common Kestrel) or foraging area (e.g. Crowned Sandgrouse) in low numbers. Apart from Sooty Falcon (“Near Threatened”) all other species are classified as to be of “Least Concern” in the IUCN Red List of Threatened Species.

Specific features, like cliffs and vegetated spots, might have an ecological function as breeding, foraging or resting habitat for the few local species. However, the importance of the project area as a habitat for local birds is very low. The project area does not hold any important breeding site for birds.

4.4 Social Environment

4.4.1 Settlements

There exists no settlement or housing within the project area and in areas required for support infrastructure.

The project area is located 8 kilometres northwest of Ras Ghareb City. The nearest neighbour to the project area is a petroleum company. The nearest police mobile station is located about 5 km from the site on the Ras Ghareb – Sheikh Fadl Road. The most important finding is that the project area is currently not utilized by Bedouin communities. The nearest Bedouin village is located about 25 km away from the area, where at least one Bedouin family (Swalam Amen Family) is known to live. No herding activities or any other activities were observed on the project location during site visits. The only Bedouin met during site visits was a worker in the petroleum company

The city of Ras Ghareb holds about 60,000 inhabitants. Ras Ghareb is the second largest city in the Red Sea Governorate and the most important Egyptian city in oil production. The city was founded in 1932 with the start of the first oil production field. It is named after the mountain Gabal Ghareb which is located about 30 km south-west of the project area. The minimum distance between the project area and the city of Ras Ghareb is about 8 km.



Figure 4.74: Areas used by the petroleum company and by Bedouins located well outside the project area

4.4.2 Land Use and Existing Infrastructure

There is very limited land-use within the project area:

- Two roads controlled and used by petrol companies cross the project area: one in the south (near observation site 11 and 12) and one in the middle (between observation sites 8 and 9).
- A 220 KV overhead powerline (OHL) runs along the eastern border of the project area (see Figure 4.75).
- In the context of wind farm development, single tracks have already been constructed (see Figure 4.75).
- In the northern part of the project area single plots can be found that were formerly used for oil exploitation by petrol pumps.
- Some tracks of 4-wheeled cars indicate a rare and irregular use of the project area.

The following land-use and existing infrastructure can be found adjacent to the project area:

- Petrol activities are carried out near to the southern and western borders of the area.
- The Suez-Hurghada road, a four lane road, runs at distances of 2.5 to 4.5 km to the eastern boundary of the project area from north to south. The Suez-Hurghada road is connected with Ras Ghareb-El Shaikh Fadel road, an asphalt road with two lanes, running at distances of at least 4.8 km south of the project area from west (the Nile Valley) to east (the Red Sea coast).
- Along Ras Ghareb-El Shaikh Fadel road two gas pipelines, a radio-link and a mobile phone mast, a military post and a storage station exist. Moreover, the 500 kV OHL runs north of Ras Ghareb-El Shaikh Fadel road connecting the 500 kV Samalut substation with 500 kV Ras Ghareb substation.

The access to the project area is via the Suez-Hurghada road. This road has very little traffic load compared to its capacity and it is fit for heavy transports. The present use of the road is rather low and suffers additional traffic capacities. Hence, there is no bottleneck with regard to traffic / heavy transport capacity on public roads. The project area itself can be reached via asphalt roads owned by the General Petroleum Company (GPC) starting from the Suez-Hurghada road north of Ras Ghareb and by single tracks already built in the context of wind farm development. The roads have sufficient strength and width and would be suitable for heavy transport. Beside these public and internal access roads most of the area can only be accessed via off-road tracks and by the use of 4-wheel drive cars.

No public water or electricity distribution system in the area exist. And there are no further human activities and no further existing infrastructure. The project area consists more or less of untouched flat levelled desert plains.



Figure 4.75: 220 KV overhead powerline at the eastern border of the project area (left) and track for wind farm development (right)

4.4.3 Social and Economic Environment

4.4.3.1 General

Ras Ghareb City is the Governorate's second largest city with around 60,000 residents. With about 70 % of Egypt's petroleum production coming from the Ras Ghareb area most of its residents work in petroleum or petroleum related activities. In fact, the city was founded in 1932 with the first petroleum field in the area and grew with the growing number of oil production companies.

Ras Ghareb is one of Egypt's largest oil-producing areas; over 40 companies specialized in oil extraction work in the area. The first oil well was drilled in 1938 by the Anglo-Egyptian Oil Wells Company, a subsidiary of Shell International, which discovered the field of Hurghada in 1911. The city

also encompasses important mineral wealth, with over 200 Quarries of different ores of marble, kaolin, glass sand, quartz and feldspar.

A large number of important raw materials such as Manganese and phosphate can also be found in the rocky structure of the Ras Ghareb's coast

The period between 2000 and 2008 witnessed the establishment of the first large-scale wind farm in Zaafarana which generates over 600 megawatts of electricity. This project made Zaafarana stand out among its neighbouring villages. The wind turbines have been manufactured and installed in a way specifically prepared to cope with Egypt's severe desert climate, sandstorms and corrosive air. Since then, the wind farm has been extended both in volume and capacity.

4.4.3.2 Demographics

The total population of the Red Sea Governorate in 2016 was estimated as 354,729 (on basis of data gathered in the 2006 census). This accounts for about 0.4 % of Egypt's total population. Red Sea Governorate is one of the three least populated governorates in Egypt, followed by the governorate ElWadi ElGidid and South Sinai.

Table 4.53 illustrates the total populations of the Red Sea Governorate, indicating a clear prevalence of male over female inhabitants in the governorate. The estimated population numbers indicate an increase from 184,781 people in year 2004 to 349,862 people in year 2015, which is about 89 % increase of the population of the Red Sea Governorate with urban population clearly exceeding rural population as shown in Table 4.54 (source: Statistical Yearbook – Population, Estimate of midyear population). This increase can be mainly explained with the high birth rate, which exceeds the mortality rate by about seven times as shown in Table 4.55.

The number of villages, districts and cities are shown in Table 4.56. The cities located in Red Sea governorate are: El Qoseir, Hala'ib, Hurghada, Marsa Alam, Ras Gharib, Safaga and Shalateen.

Table 4.53: Estimated population and their percentage distribution by sex in 2016 (CAPMAS)

Governorate	Share of total population in Egypt [%]	Total	Female	Male
Red Sea	0.4	354,263	143,317	210,946

Table 4.54: Population in governorates (urban/rural) according to final results of 2006 population census (CAPMAS)

Governorate	Share of total population in Egypt [%]	Total	Rural	Urban
Red Sea	0.4	288,661	12,933	275,728

Table 4.55: Birth, mortality and natural increase rates by governorate (urban/rural) 2014 (rate: per 1,000 of Population). (Vital Statistics, Egypt in figures 2016, CAPMAS)

Governorate	Natural increase			Mortality			Births		
	Total	Rural	Urban	Total	Rural	Urban	Total	Rural	Urban
Red Sea	25.4	79.6	16.3	4.8	16.6	4.2	30.2	96.2	20.5

Table 4.56: Administrative and municipal sections in Red Sea Governorate (Statistical Yearbook-Housing 2014, CAPMAS)

Governorate	No. of Villages	No. of Districts	No. of Cities
Red Sea	11	2	7

According to CAPMAS data the number of schools in the Red Sea area is low in comparison with total schools in Egypt (Table 4.57). The total numbers of schools in Egypt in comparison with schools in Red Sea governorate as per different educational stages are:

Number of pre-primary education school: 11,064 (2016, CAPMAS)

Number of primary education school: 18,085 (2016, CAPMAS)

Number of preparatory education school: 11,466 (2016, CAPMAS)

Number of secondary education school: 2,994 (2014, CAPMAS)

The educational status of the population of the Red Sea Governorate is given in Table 4.58.

Table 4.57: Number of schools in Red Sea Governorate (2014 and 2016, CAPMAS)

School type	Pre-primary stage	Primary stage	Preparatory stage	Technical secondary education		
				Agricultural	Commercial	Industrial
no. of schools	78	104	79	0	13	22

Table 4.58: Population and Educational status (Statistical Yearbook-population, 2006 census CAPMAS)

Educational status	% of the population in Red Sea Governorate
Illiterate	12.7%
Read & Write	7.6%
Illiteracy Erase	1.7%
Below Intermediate	18.2%
Intermediate	35.5%
Above Intermediate	4.9%
University	13.1%
Above University	0.2%
Not Stated	6.1%

4.4.3.3 Labour Force

Due to the petroleum economy in the area, unemployment at Ras Ghareb is assumed to be lower than the Egyptian average, which is currently between 12 and 13 %. However, there will be still a certain rate of unemployment.

As for the Bedouin community, while Maaza is the dominant tribe, there are several others in the area, these include: Areynat, Juhaina, Rashayda, Abs, Aryeanat and Azayzah. The Areaynat in Zaafarana work in grazing sheep, tourist camps, mountain safaris and guard mobile towers, roads as well as other facilities. On the other hand, the Areynat and the Azayzah are concentrated at Ras Ghareb and work in public and private sectors. As for Red Sea Bedouin communities, they rely on herding and fishing as their main sources of livelihood. While most of the communities along the coast are engaged in fishing and to a lesser extent in herding, deep-range communities located further inland are exclusively herders. Fishing and herding are not restricted to men alone. Women engage in shoreline fishing and herding as well. Fish catch is mostly consumed fresh by the locals, and the surplus is salted and dried for their future consumption. Some selected fishes are sold to visiting merchants for a price decided through negotiation.

The development of the artisan fisheries of the area was boosted in the mid-nineties by the development in means of transportation and the industries infrastructure associated with the increased demand for fish. This was also enhanced by the regular or sometimes continuous presence of fish merchants and/or middlemen in the area. The presence of merchants in the area was not only creating a good marketing opportunity, but also guaranteed a reliable source of ice, fishing gear repair, maintenance material and other fishing commodities and services that are otherwise hard to get.

Most community members who work in herding are shepherds and goatherds. Some of them also raise camels. In times of drought, some families travel with their herds as far south as Shalateen and Gabal Elba in search of suitable grazing land. To make ends meet, families attempt to diversify their economic activities by engaging in charcoal production or trading as an alternative source of income-generation.

Table 4.59 provide an overview of the estimates of the employed persons in the Red Sea Governorate in the industry classification, according to Labor Statistical Yearbook 2014

Table 4.59: Estimated of employed persons by sex and industry in Red Sea Governorate 2014 (Statistical Yearbook – Labor, CAPMAS)

Industry	Male	Female	Total
Agriculture, hunting, forestry & cutting of wood trees	6,200	300	6,500
Mining & quarrying	1,300	0	1,300
Manufactures	7,100	300	7,400
Electric, gas, steam, air condition supplies	1,900	0	1,900
Water support, draine, recycling	600	0	600
Constractions & building	6,800	0	6,800
Whole and retail sale vehicles, motorcycles repairing	12,300	1,000	13,300
Transportation & storage	6,200	0	6,200
Food, residence services	7,800	300	8,100
Informations, telecommunications	1,300	500	1,800
Insurance & financial intermediation	600	0	600
Specialized technical, scientific activities	9,400	300	9,700
Adminstrative activities & support services	1,600	0	1,600
Public Administration, defense, social solidarity	10,100	3,300	13,400
Education	4,900	8,000	12,900
Health and social work	300	1,800	2,100
Amusement & creation & arts activities	600	0	600
Other services activities	1,000	500	1,500
Services of home service for private households	600	0	600
Total	80,600	16,300	96,900

4.4.4 Ambient Noise Levels

No measurements of the ambient noise level were carried due to the obvious lack of any sensitive receiving receptor in and around the project area.

There exists a natural high noise level during frequent strong winds within the project area.

There is very few traffic on the asphalt road used by the petrol companies. Such punctual noise emissions of cars are negligible compared to the natural noise level. Beside this, no man made noise emissions occur in the area.

In absence of sensitive receiving bodies within and at greater distances to the project area the ambient noise level is of minor relevance.

4.4.5 Archaeological, Historical and Cultural Heritage

The area neither contains any historical, archaeological or cultural site nor is located inside or nearby such an area. There are no antiquities or other sites of historic and cultural significance in the wider surrounding of the project area.

5. Impact Prediction and Evaluation

5.1 General and Basic Methodology

The prediction of environmental and social effects caused by wind farm developments in the project area is based on current knowledge on the specific impacts of wind power projects and long-lasting experience in this field and considers the results of conducted site visits. The following chapters cover an assessment of the impacts likely caused by wind farms and associated infrastructure in the project area during construction phase, operation and maintenance phase and decommission phase (where appropriate construction and decommission phase are considered together).

An impact is defined where project activity–receptor interactions occur. According to ISO14001:2004 an impact is defined as: “Any change to the environment, whether adverse or beneficial, wholly or partially resulting from an organisation’s environmental aspects (activities, products or services)”.

Once the impacts are fully understood, it is necessary to judge the significance of each impact, to determine whether it is acceptable, requires mitigation or is unacceptable. Within the assessment process impacts are ranked according to their “significance” which is a function of “event magnitude” and “receptor sensitivity” (see Figure 5.1). Determining event magnitude requires the identification and quantification (as far as practical) of the sources of potential environmental and social effects from routine and non-routine project activities. Determining receptor environmental sensitivity requires an understanding of the biophysical environment. Criteria for the assessment are for instance:

- Area of influence
The magnitude of an effect is often directly related to the size of the area affected (e.g. the acres of land disturbed).
- Percentage of resource affected
The greater the percentage of a resource affected, the higher the magnitude of an effect.
- Persistence of effects
Permanent or long-term changes are usually more relevant than temporary ones (the ability of a resource to recover after activities are complete is related to this effect).
- Sensitivity of resources
Stimuli to sensitive resources are usually more relevant than those to resources that are resilient.
- Status of resources
Effects to rare or limited resources are usually considered more significant than effects to common or abundant resources.
- Regulatory status
Effects to resources that are protected (e.g. endangered species, wetlands, air quality, cultural resources, water quality) typically are considered to be more significant than effects to those without regulatory status (many resources with regulatory status are rare or limited).
- Societal value
Some resources have societal value, such as sacred sites, traditional subsistence resources and recreational areas (some of these resources might also have regulatory status).

Impact Assessment has to

- be receptor or subject-specific;
- distinguish between different project phases (construction, operation, decommission; and
- distinguish between different “impact paths”.

		Sensitivity		
		Low	Medium	High
Magnitude of effect	Low	negligible	minor	moderate
	Medium	minor	moderate	major
	High	moderate	major	major

Figure 5.1: Assessment of significance (negligible, minor, moderate, major) as a function of receptor sensitivity and event magnitude

Under consideration of this general approach and the specific impacts typically caused by wind power projects, one can assume that the expected or possible environmental and social effects of a large wind farm are quite limited in a desert area. This is valid for the construction, for the operation and maintenance and for the decommission phases. The limitation of environmental impacts is due to the character of the area and the project, i.e. factors like:

- the desert nature of the area with a hyper-arid climate without any population, with very limited or even no vegetation and wildlife inside or near to the area;
- the small direct land take of the total project area; and
- the remoteness of the site without any receiving bodies that might be affected by noise, shadowing or landscape deterioration.

5.2 Physical Environment

5.2.1 Climate

Construction and Decommission Phase

As construction and decommission activities for wind farm developments and for associated infrastructure will be limited in time and space, they will have no significant negative effect on the climate.

Operation and Maintenance Phase

Conventional electricity generation techniques, specifically those associated with combustion of fossil fuels, emit high levels of carbon dioxide (CO₂) and contribute to climate change. As wind farm developments will provide renewable energy, they will help towards replacing the use of fossil fuel and, hence, reducing the amount of greenhouse gas emissions.

For instance, Zafarana wind farms, which is located about 60 km north of the project area, has very effective and positive impacts: operation of the 600 MW wind farms will produce 42,000 million kWh all over their 20 years life time, that in turn will save 10 million tons oil equivalent and will abate the emission of the following quantities of greenhouse gases: 588 Mio ton CO_x, 2.1 Mio ton NO_x, 8.4 Mio ton SO_x.

To conclude, operation of wind farms in the project area will have a positive impact on climate.

5.2.2 Flash Flood

Flash floods in wadi systems can cause severe damages to human life, infrastructure such as roads and buildings as well as to the environment. Flash floods are caused by very rare, but extreme weather conditions, their occurrence is highly random and associated problems are hardly to be predicted in the near future.

Heavy rainfall rarely occurs in the project area; if it happens there will be direct discharge to groundwater through sandy soil. Heavy rains in the mountains can cause flash floods in the wadis such as Wadi al- al-Hawwashiyah in the south of the project area. The figure below shows the Red Sea hydrographic with the major Wadis. The main eastern watershed basins affecting the stretch of the area are Wadi El-Dakhel, Wadi al- al-Hawwashiyah, Wadi Gharib, Wadi Dara, Wadi Abu Had, Wadi Mellaha, Wadi Beilit. Figure 4.11 shows also the schematic location of the main Wadis, which are located in the project area.

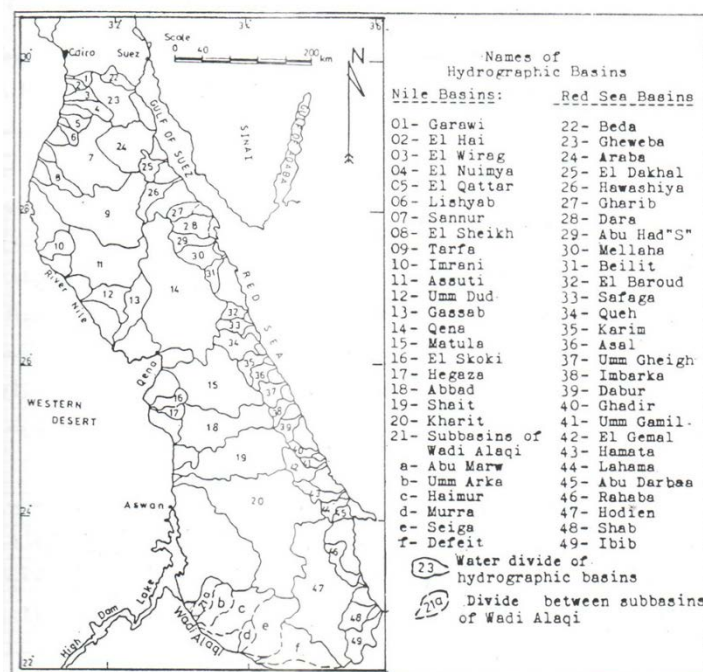

Figure 5.2: Red Sea and Eastern Desert drainage system

There is no statistical evidence on the occurrence interval of such rains. The big dimensions of the wadis and erosion channels in the wadi beds are evidence for discharge in the wadis that occur from time to time. The discharge may have the form of flash floods that is believed to occur with a likelihood of about one in ten years.

Accordingly, wind turbines (even those with protected foundations) shall not be placed inside the beds of larger wadis. In case the internal wind farm roads or access roads are crossing the wadis, special precautions shall be met in order to avoid blocking of the natural drainage system. Precast concrete box culverts or pipe culvert shall be used in case of crossing of wadis and roads.

According to the Egyptian National Water Resource Plan harvesting of flash floods may be considered in the Eastern Desert through the development of reservoirs for storage and infiltration to recharge the groundwater. Such schemes will only be considered in areas where small dams also have an important flood protection function or where no other options are available (National Water Resource Plan 2017, Ministry of Water Resources and Irrigation, Arab Republic of Egypt) Finding solutions to these challenging problems requires close collaboration between scientists and stakeholders from government, public organizations and the private sector.

To sum up, the risk of flash flood in the project area is recognized as a minor to moderate risk that can be mitigated by avoiding turbine installations in the wadi beds. In addition, it might be necessary to consider this issue in more detail during the preparation of project-specific ESIA's.

On other hand, it is not expected that the wind energy projects in the area will have an effect on the occurrence of flash floods in the area – neither during construction nor during operation.

5.2.3 Air Quality

Construction and Decommission Phase

Construction and decommission activities for wind farm developments and for associated infrastructure have the potential to affect air quality mainly due to the dust created by activities during demolition, completion of ground works and construction / decommission. Resuspension of dust through activities on the site or the wind can cause a nuisance and affect human health and vegetation. Concerns are most likely near to dust sources, usually within 100 metres. However, there are a wide range of dust control measures that are commonly used on construction sites (see Chapter 6.2). The dry climate in combination with the prevailing strong northern winds in the project area cause favourable conditions for dust generation and dust emissions. Hence, as far as necessary and reasonable, mitigation measures shall be incorporated into the Environmental and Social Management Plan (ESMP). Under consideration of appropriate measures any emissions will be of a temporary nature and at large distance from residential properties and valuable habitats, thus minimising any potential for a nuisance or impacts to occur.

In addition, construction plant and vehicles can affect air quality as a result of exhaust emissions. These could lead to a negative impact, particularly if plant passed or operated in the vicinity of occupational residences and if the number of vehicles was significant. However, in the absence of sensitive receptors (humans, animals and plants) in or near the project area such emissions during construction / decommission, such local and temporary deterioration of the air quality will have no relevant adverse impact.

On-site operating plant, including diesel generators, will generate emissions, too. Due to the scale of the operations these will not be relevant. In order to ensure that emissions from all vehicles and plant are as low as possible, all vehicles shall be in a good state of repair.

There will be no on site burning of any material, therefore there will be no such emissions as a result of the construction / decommission activities.

Under consideration of the specific conditions of the project area and its surrounding (e.g. no sensitive receptors) and taking appropriate mitigation measures into account, emissions during construction / decommission will be temporary and will have no relevant adverse impact on air quality.

Operation and Maintenance Phase

No dust and gaseous emissions will originate from wind farm developments and associated infrastructure during operation. Accordingly, there is no relevant adverse impact on air quality.

5.2.4 Water Resources and Waste Water

Construction and Decommission Phase

There will be no direct discharge to groundwater or surface water (which only rarely occurs in the wadis after heavy rainfall) during construction / decommission activities for wind farm developments and associated infrastructure.

However, as a result of accident, construction / decommission activities have the potential to release pollutants to the ground and, hence, to the groundwater and / or surface water. Potential sources of pollution include:

- accidental release of fuels, oils, chemicals, etc. to the ground, especially in the construction lay-down area, during delivery, storage, handling and use (e.g. re-fuelling, maintenance activities);
- accidental release of liquid wastes during storage, handling and removal, with subsequent leaching to groundwater;
- accidental discharge of sanitary wastewater to ground and groundwater from the workers domestic facilities; and
- discharge of pollutants in water used for plant, equipment and vehicle washing to ground and subsequent leaching to the groundwater.

Measures have to be implemented to reduce the risk posed by these potential sources of pollutants. All possible steps shall be taken to prevent materials being imported onto the site which are already polluted. Potentially polluting materials, such as fuels, oils, chemicals and associated liquid waste materials shall be stored in dedicated, segregated storage areas, with spillage protection and appropriate environmental security measures to prevent accidental release to ground during storage. In addition, appropriate working procedures shall be adopted to

- minimise the risk of accidental release during delivery to and removal from the storage areas;
- ensure that materials (raw and waste) are handled correctly; and
- prevent accidental release during the use of these materials (e.g. vehicle refuelling and plant maintenance).

Water will be required during the construction for concrete pouring, road construction and cable trenches construction. Table 5.1 shows the required maximum water during the construction of a wind farm with an installed capacity of 50 MW. The assumption is done for 25 WTG with and approximately road and cable trenches of 10 km and road width of 6 m.

The daily pick of the quantity of the water during the construction is expected to be 200 m³ per day if the concrete batching plant is constructed at site. Water supply will be usually via tankers as it is assumed the concrete batching plant will be constructed at the site. If the concrete will be provided

as ready mix, than the quantity mentioned for the WTG foundation pouring shall not be taken into consideration.

In additional, temporary construction yards (for storage of materials and servicing of machinery) and temporary offices will be erected at a central places for construction / decommission activities for wind farm developments and for associated infrastructure. The offices will avail of simple sanitary facilities. Water supply will be usually via tankers from the central pipeline. It is assumed the maximum quantity of water required in the camp office to be 20-30 m³ per construction site for an installed capacity of 50 MW. Waste water quantities should be of an order of less than 1 m³/d per construction site (for a single 50 MW wind farm). The site will not be connected to the local waste water collection system and there will be no waste water treatment on site. Sanitary waste water shall be collected at site and shall be removed from site for treatment at an appropriate treatment facility. Waste water will not be discharged to either groundwater or surface water.

In the event that the aforementioned measures will be implemented no significant adverse impacts on ground-water or surface water is expected by the construction / decommission of wind farm developments and associated infrastructure.

Table 5.1: Assumed water quantity during the construction

Activity	Maximum daily water requirement
WTG foundation pouring	50 m ³ per WTG foundation, as it is assumed that the size of the foundation is about 400 m ³
WTG foundation curing	1 m ³ per foundation per day, as it is assumed that 10 days will be sufficient for foundation curing
WTG components cleaning before erection	2 m ³ per wind turbine
Road works	20 m ³ per day, as it is assumed that 100 m of roads are constructed
Power cable trenches	2 m ³ per day, as it is assumed that 100 m of cable trenches are constructed
Substation construction	5 m ³ per day
Dust control during the construction	20-40 m ³ per day

Operation and Maintenance Phase

No liquid emissions will originate during operation of wind farms and the associated infrastructure in the project area.

Even though assuming that service facilities (control room, storage room, rooms for O & M personnel) will be constructed in the project area, fresh water consumption for wind farms and associated infrastructure, essentially caused by human demand, would not be significant.

Domestic waste water will accumulate from the service facilities:

- substation control room (3 persons à 30 l/d): 0.090 m³/d
- service facilities including housing for personnel inside or outside the project area for wind farm capacities of about 400 MW: (50 persons à 40 l/d): 2.0 m³/d

Accordingly, the amount of domestic waste water generated would be less than 3 m³/d. The project area will not be connected to the local waste water collection system and there will be no waste water treatment on site. Sanitary waste water shall be collected at site and removed from site for treatment at an appropriate treatment facility. Waste water shall not be discharged to either groundwater or surface water.

Fresh water consumption, essentially caused by human demand, will not be significant.

No relevant adverse impact on groundwater or surface water is expected during operation and maintenance of wind farm developments and associated infrastructure, if the aforementioned measures are considered.

5.2.5 Geomorphology and Soil

Topographical Restrictions

There are no restrictions to wind farm installation resulting from foundation bearing capacities. In addition the project area is almost free from special topographical features and rather uniform allowing an equal spatial distribution of wind turbines. However, turbine construction at major wadis shall be avoided because wadis are prone to flash floods, which may occur from time to time. Earth roads to cross wadi beds shall be built at the same level as the wadi Bed to avoid major destructions in case of flash floods and to avoid creating any bottleneck for the discharge. This approach also warrants that construction measures are kept at a minimum and that the existing few plots of vegetation will remain almost undisturbed.

Construction and Operation and Maintenance Phase

Construction activities for wind farm developments and associated infrastructure will result in adverse changes of land cover and in a compaction of soil in localized areas. This impact will remain for the whole operation and maintenance phase. The required area will marginally larger during the construction phase due to temporary additional working areas, construction yards and storage facilities.

It is worth noting that wind farms and associated infrastructure will ultimately occupy a large area of, but given the relatively small footprint attributed to single turbines and to single pylons of powerlines, construction impacts on land cover will occur within relatively small and localized plots across the project area (usually less than 2 %). In addition, the affected plots consist of desert land without any vegetation. Hence, due to the limited footprint of the works no relevant adverse changes to land cover and soil are expected. In the absence of sensitive areas land take will have a negligible impact on geomorphology and soil.

During construction and operation / maintenance of wind farm developments and associated infrastructure there will be no direct discharge to the ground (topsoil, subsoil and natural strata). However, as a result of accidents construction and / or maintenance activities have the potential to release pollutants to the ground. Measures shall be employed to reduce the risk posed by the potential sources of pollutants (see Chapter 6.2).

Decommission Phase

The effect from decommissioning will be through temporary disturbance to the site from heavy plant and vehicle movement. Works during the decommissioning phase would involve activities similar to those used during the construction phase. Therefore these effects would be similar to and not greater than those that may occur during the construction of wind farms.

Measures shall be employed to reduce the risk posed by the potential sources of pollutants during the decommission phase (see Chapter 6.2).

5.2.6 Landscape Character and Existing Views

Construction Phase

Wind farm developments will result in a considerable negative change in the landscape character during construction phase due to the increased 'urbanisation' of the landscape associated with activities such as the movement of crane vehicles for the delivery and installation of the turbines and erection of the electricity pylons and erection of buildings within a so far more or less untouched desert area. However, as these activities will occur within a rather short period of time effects will be temporary and transient and will not lead to a relevant adverse impact.

Operation and Maintenance Phase

The prominence and operation of large wind farms and associated infrastructure will cause a negative change to the landscape character of the project area and its immediate surrounding. This is due to the introduction of tall vertical, industrial structures in a predominantly low and open landscape which can be characterized as a more or less untouched desert area. The turbines and to a lesser extent the electricity pylons will introduce modern and dominant elements to the landscape which would both dwarf existing structures and elements and contrast with the character of the desert landscape. Therefore they will become the dominant feature and a key characteristic of the landscape within the area. As a result the project will cause an adverse impact on the landscape character.

The magnitude of the visual impact of a wind farm usually depends upon the position of visual receptors and their sensitivity. The sensitivity is based on the type of receptor, as well as the special nature of the view. For example, residential properties are considered to have a high sensitivity. Additional factors to be considered in the classification of sensitivity of visual receptors include:

- period of exposure to view;
- degree of exposure to view;
- function and the personal attitude and opinion of receptor; and
- nature of the view.

The perception of tall, man-made structures and, hence, their visual impact decreases with increasing distance of a receptor. In this regard weather conditions and daylight are very important. According to several European guidelines and regulations (e.g. Breuer 2001, University of Newcastle 2002, Hessischer Landtag 2012) four zones of potential visual impact can be distinguished (see Table 5.2).

Based on the above mentioned classification, the areas probably affected by high, moderate and low visual impacts of wind farm developments have been analysed. Thus, no people live in an area that is assumed to be significantly impacted. Few facilities of the petrol company are located within an area of high visual impact (mainly at the southern border of the project area) and other facilities in an area of moderate impact. The Suez-Hurghada road runs for about 45.0 km through an area of moderate impact.

Table 5.2: Classification of four different zones of potential visual impact (depending on the distance to the receptor)

Distance	Perception of tall, man-made structures	Impact
Up to 2 km	perceptible, likely to be a prominent feature in the landscape	high impact
2 to 5 km	regularly perceptible, relatively prominent	moderate impact
5 to 10 km	only perceptible in clear visibility, seen as part of the wider landscape	low impact
> 10 km	only occasionally seen in very clear visibility, only minor element in the landscape (if at all)	no relevant impact

An impression of the landscape character after installation of a wind farm in the desert at the Red Sea coast gives Figure 5.3 (visualizations that have been made with Software WindPRO 2.8 (Modul VISUAL), ENERGI- OG MILJØDATA (EMD)). The visualizations clearly show that the turbines in the area of high visual impact are prominent features in the landscape. At larger distances turbines are still easily perceptible, but do not act as the dominant element in the landscape anymore.

To sum up, in the absence of people living in an area probably affected by wind farm developments and considering that only few passengers are passing the area on the Suez-Hurghada road the magnitude of adverse visual impacts is assessed as moderate.



Figure 5.3: Visualisations of an exemplary wind farm in the desert landscape at the Red Sea coast

5.3 Biological Environment

5.3.1 Protected Areas

As shown in Chapter 4.3.1, a small part of the project area overlaps with the so-called “Gebel el Zeit” area (EG031) which was nominated as an Important Bird Area (IBA) by BirdLife International (see Map 4.1; BirdLife International 2017). The Gebel El Zeit area was designated as an IBA mainly due to its importance as a migration corridor for large soaring birds, particularly birds of prey and storks (BirdLife International 2017).

The expected impact of wind farm developments within the project area on migrating soaring birds is thoroughly assessed in Chapter 5.3.4. Mitigation measures particularly required to minimize any potential impact to an acceptable level are proposed in Chapter 6.4.2.2 under consideration of the precautionary principle. Hence, the ecological function of the IBA will not be decreased by operational wind farms, if appropriate mitigation measures will be considered and thoroughly implemented. On the other hand one has to acknowledge that there is still a high degree of uncertainty when predicting the effects of large wind farms on migrating birds. Current studies conducted at the wind farm La Venta II, which comprises 98 wind turbines and is located in the Isthmus of Tehuantepec in southern Mexico, have shown that migratory soaring birds adjust their flight paths suggesting a strong avoidance pattern during autumn migration and a possible avoidance pattern during spring migration (Villegas-Patracá 2016, Cabrera-Cruz & Villegas-Patracá 2016). Assuming such a macro-avoidance behaviour of migrating soaring birds, large wind farms likely have the potential to negatively affect the ecological function of an area as a migration corridor.

On that background it is recommended to discuss development of wind turbines in the small south-eastern part of the project area amongst relevant stakeholders during the coming public consultation process ensuring the preservation of the ecological function of the IBA Gebel El Zeit as a migration corridor for large soaring birds.

5.3.2 Habitats

Construction phase

As given in Chapter 4.3.3, most parts of the project area have a very low to no importance as a habitat for plants and, thus, for animals. Only at single locations in the major wadis suitable living conditions for single plant species were found. As given above, turbine installation in major wadis shall be avoided ensuring that construction measures are kept at a minimum and that the existing few plots of vegetation will remain almost undisturbed. To conclude, wind farm development and associated infrastructure in the project will lead to only negligible or minor impacts.

Specific structures that might carry particular ecological functions for plants and/or animals shall in any case remain unaffected, e.g. caves functioning as a shelter for animals during day or as a suitable breeding site for local birds (see Figure 4.13). As these structures are of small scale, this issue cannot be thoroughly considered in the SESA, but shall be within the scope of project-specific ESAs.

Operation and maintenance phase

Due to the very low importance of the project area as a suitable habitat for plants and animals, operation of wind farms and associated infrastructure will not have a relevant adverse impact.

5.3.3 Flora and Fauna (except birds)

5.3.3.1 Flora

As the results given in Chapter 4.3.3.1 clearly show, the importance of the project area as a habitat for plant species is very limited. All species found within the project area are common and widespread in the Eastern Desert and, thus, not believed to be endangered or threatened.

Construction Phase

Construction of wind power projects and associated infrastructure in the project area might lead to:

- Direct damage of plants and modification or direct loss of habitat by using areas for fundamentals of turbines, pylons, buildings and of auxiliaries, permanent access roads, erection platforms, trails for power lines, storing positions for heavy machines, other technical installations.

During construction of wind farms which includes mobilization and demobilization a removal and partial destruction of the top soil surface and some deeper soil layers will occur. However, the land take by wind farm developments (incl. associated infrastructure) is very limited (usually less than 2% of the overall area) leaving most of the area free from any interventions. Consequently, the affected area will cover only a small fraction of the project area which is free of vegetation.

- Compaction of soil due to land-use

Compaction of soil might lead to a damage of local seed banks and a reduction of the suitability for plant growth. However, as the potential for plant growing in this hyper-arid area is very limited this is valued as minor impact. Moreover, as stated above the affected area is very limited (usually less than 2 % of the project area), leaving most of the area free from any interventions. Furthermore, the area comprises no threatened species or plant communities of conservational concern.

- Dust emissions

Dust emissions will be limited to a very small area and limited to rather brief periods. No relevant adverse impact on flora is expected due to dust emissions.

- Waste

Waste resulting from constructional work will cause no relevant adverse impact on flora. However, it might pollute larger areas when drifted away by strong winds. Thus, waste shall be removed immediately from the site and shall be stored at or near the site in appropriate ways (in closed or covered tanks / vehicles to prevent materials being blown).

In conclusion, construction of wind power projects and associated infrastructure within the project area will cause no relevant adverse impacts on vegetation or plant communities.

Operation and Maintenance Phase

Areas directly affected by wind farms and associated infrastructure will mainly be without vegetation. Operating wind turbines are not known to affect plants or plant growth. Also slight changes in wind speed (turbulences) or in microclimate at ground level will have no effect on plants.

During periods of maintenance of wind farms human activities will be restricted to the already existing roads, tracks and storage positions.

In conclusion, operation and maintenance for wind farm developments and associated infrastructure will cause no relevant adverse impacts on vegetation or plant communities. There are also no other activities in the area that might contribute to increased impacts to non-acceptable levels.

Decommission Phase

The primary effect from decommissioning will be through temporary disturbance to the site from heavy plant and vehicle movement. Works during the decommissioning phase would involve activities similar to those used during the construction phase; therefore these effects would be similar to and no greater than those that may occur during the construction of wind farms.

5.3.3.2 Fauna

Few numbers of mammal, reptile and invertebrate species were recorded in the project area (Chapter 4.3.3.2). Most species are quite common throughout the Eastern Desert. The only species of conservational concern is the Egyptian Dabb Lizard that is considered to be “Vulnerable” (according to IUCN Red List of Threatened Species). In addition, the Egyptian Dabb Lizard is formally protected by Egyptian legislation, and so are Rüppell's Sand Fox, Egyptian Jackal and Cape Hare. None of the other species recorded during site visits or expected to occur in the project area are known to be endangered or threatened. The area seems to be a rather suitable site for some reptile species of which most are quite common and widespread. For other species the habitat potential of the project area is rather limited.

Construction Phase

Construction of wind power projects and associated infrastructure might lead to:

- A loss of habitat for local animals by using areas for fundamentals of turbines, pylons, buildings, permanent access roads, trails for power lines, storing positions for heavy machinery, other technical installations etc.

As stated in Chapter 4.3.3.2, the local animal communities have very few species. Moreover, density is very low. Compared to the whole project area, the area required for infrastructural structures is very small. Thus, even after turbine erection there will be enough appropriate habitats available for local animals, even for the Egyptian Dabb Lizard and pother species protected by Egyptian legislation. In summary, the impact on animals caused during construction phase is not assessed as relevant.

- Disturbances by human activities from heavy machines, traffic, noise and dust emission.

Local animals might be affected by disturbances during the construction phase. Large native mammals (probably Desert Red Fox, Rüppell's Sand Fox) that sporadically use the area will most likely abandon the construction site because of the disturbance from constructional work. However, disturbance effects are limited to a rather small area compared to the whole project area. Thus, local animals, as the Egyptian Dabb Lizard and other species protected by Egyptian legislation, can find alternative habitats during construction. Moreover, constructional work is limited to a rather short period of time. Local animals can repopulate all areas after construction. In summary, the impact on animals caused by disturbance is not assessed as relevant.

- Waste

Waste resulting from constructional work will cause no relevant adverse impact on fauna. It will probably attract certain animals, however, especially feral species (dogs, cats, rodents, etc.). This might affect indigenous species. Thus, waste shall be removed immediately from the site and shall be stored at the site in appropriate ways.

- New species of urban and rural environments

New species of urban and rural environments can be imported into the area together with construction materials and containers. This shall be avoided as much as possible, because new species have the potential to affect indigenous species.

Operation and maintenance phase

There exists no evidence for the assumption that noise and shading resulting from operating turbines might affect terrestrial mammal or reptile species. Moreover, noise and shading are limited in space and time. Hence, operating wind farms are not expected to impact animal wildlife significantly.

There might be a risk of disturbance of species by site personnel, by waste from used spare parts or by hazards from non-sufficiently isolated cables during maintenance activities. Disturbance will cause no relevant adverse impact on animal wildlife, as maintenance activities are restricted to the area close to the wind turbines.

Decommission phase

The primary effect from decommissioning will be through temporary disturbance to the site from heavy plant and vehicle movement. Works during the decommissioning phase would involve activities similar to those used during the construction phase; therefore these effects would be similar to and no greater than those that may occur during the construction of wind farms.

5.3.4 Birds - Avifauna

5.3.4.1 Predicting and Assessing Possible Impacts on Migrating Birds

5.3.4.1.1 Bird Wind Turbine Interactions

Birds in active flight are not affected by the construction of wind turbines. Noise and dust emission at distinct construction sites might bring migrating birds to alter their flight path, but this cannot be regarded as a significant adverse impact. Hence, construction of wind farms does not cause significant impacts on migrating birds - neither on target species nor on species of minor relevance.

Considering utilization of wind energy within the project area, the major potential hazards to migrating birds are mortality due to collision as well as barrier effects. Migrating birds of target species might be significantly affected by an operating wind farm (a comprehensive review on possible effects of operational wind farms on migrating birds is given in Annex VI). Thus, in the following the potential effects of operational wind farms in the project area are analyzed and discussed for migrating birds of target species.

Migrating birds of species of minor relevance (mainly passerines) do not concentrate in certain areas and, in addition, collisions at onshore wind farms do not seem to be a major concern (according to current knowledge). Hence, no significant adverse impacts are expected when operating wind farms in the project area. Consequently, there is no need for a detailed assessment of effects on migrating birds of species of minor relevance.

5.3.4.1.2 General Remarks on Limitations of Risk Assessment

Collision risk at modern wind turbines depends on several factors and until now the cause-and-effect chain of collision is poorly understood. Very little is known about collision risk for migrating birds (see Annex VI).

There have been a few attempts to predict collision rate at given wind farms with mathematical models (e.g. Band et al. 2007). Modelling collision risk under the Band model is a two-stage process. Stage 1 estimates the number of birds that fly through the rotor-swept area. Stage 2 predicts the proportion of these birds that will be hit by a rotor blade. The reliability of the collision model is

limited by difficulties in gathering appropriate field data and by the large numbers of assumptions necessary during the modelling process, notably the level of collision avoidance (see Vasilakis et al. 2016 for an example). As a consequence, care must be taken not to overstate the model outputs (e.g. Weitekamp et al. 2015). Nevertheless, Madders & Whitfield (2006) pointed out that alternative methods for estimating collision risk are less transparent or more subjective and at least vulnerable to the same potential biases. In contrast, Chamberlain et al. (2006) suggest that the value of the Band collision risk model in estimating actual mortality rates is questionable until species-specific and state-specific avoidance probabilities can be better established. Therefore, the authors do not recommend the use of the model without further research into avoidance rates. Langston & Pullan (2004) sum up that collision risk models provide a potentially useful means of predicting the scale of collision attributable to wind turbines in a given location, but only if they incorporate actual avoidance rates in response to fixed structures and post-construction assessment of collision risk at wind farms that do proceed, to verify the models.

Similarly, based on a comprehensive investigation conducted at several wind farms in Germany, Grünkorn et al. (2016) conclude that CRMs, like the Band-Model, are not appropriate to calculate reliable collision rates of birds at a given wind farm. The same is valid for collision rates at overhead powerlines, in particular in such an extraordinary region as the Red Sea coast.

A current review of avian CRMs conducted by Masden & Cook (2016) reveals that

- CRMs underlie several limitations with regard to the uncertainty of assumptions required for input parameters relating both to the birds (e.g. bird numbers, flight speed, bird behaviour, avoidance rate, morphometrics) and the turbines (e.g. rotor speed, blade width);
- lack of data on model inputs weaken the validity of CRM; and
- opportunities for model validation are very limited (CRMs “are rarely validated, but where they have been, predictions from EIA often show only a weak relationship with observed effects and predictor variables”; Masden & Cook (2016, p. 48)).

Masden & Cook (2016, p. 48) conclude that at present CRMs “estimates provide a means of comparison between different development or management options but the estimates should only be considered indicative and never absolute.”

In summary, it is very difficult for several reasons to assess collision risk as well as avoidance behaviour, which might lead to increased energy expenditure caused by a proposed wind power plant. Thus, the following impact assessment should be regarded as a qualitative prediction of possible impacts under consideration of the precautionary principle (worst-case-approach), which needs to be specified by further field investigations in bird-wind turbine interactions (e.g. post-construction monitoring) at the western Red Sea coast.

5.3.4.1.3 Predicting and Assessing the Weight of Collision Risk for Migrating Soaring Birds

Autumn migration

As given in Chapter 4.3.4.3, the project area is not of particular importance for large soaring birds during autumn migration. Over vast periods of the autumn season migratory activity of relevant species was low. Remarkable migratory activity was restricted to single days and mainly referred to larger flocks of three species (European Honey Buzzard, White Stork and Great and White Pelican made up about 98 % of all recorded birds). None of these species is considered as to be threatened or near threatened.

As a consequence, collision risk at a wind farm in the project area is not assumed to pose a major threat for large soaring birds in autumn. Single collisions at a wind farm within the project area might occur even during autumn migration, but the expected collision rate will not cause significant effects

on the populations. Thus, collisions at wind turbines within the project area during autumn are not believed to have a significant impact on migrating birds. This assessment needs to be verified by a thorough post-construction monitoring at operating wind farms (see Chapter 6.4.2.2). Furthermore, general mitigation measures shall be applied to reduce collision risk as much as possible (Chapter 6.4.2.2).

Spring migration

As given in Chapter 4.3.4.4, very high numbers of large soaring birds have been recorded in the project area in spring 2017. Though migration of relevant species was low over larger periods, a very high migratory activity was obtained on single days. Relevant numbers of “Endangered” or “Vulnerable” species (according to the IUCN Red List) occurred in the area, in particular Steppe Eagle with 4,740 individuals. Hence, the importance of the project area for large soaring birds in spring has to be assessed as high.

Though there is not always a strict correlation between abundance of birds and collision rate (see Annex VI), it is reasonable to assume that collision risk is higher in areas with high bird densities. Consequently, collision rates leading to additional mortality potentially causing significant population effects for some species cannot be excluded when operating a large wind farm within the project area.

This applies particularly to Steppe Eagle which was classified as “Endangered” by IUCN and which is known to occur in relevant numbers over the desert plains at the Red Sea coast during spring. Aside from Steppe Eagle, Short-toed Snake Eagle and Booted Eagle might also be significantly affected by operating wind farms in the project area, because Eagles are very passive fliers and hence are vulnerable to collisions. On the other hand, at the western coast of the Gulf of Suez (and within the project area), the majority of Eagles tend to migrate at altitudes well above 120 m (see also Bergen 2007, Bergen & Gaedicke 2013, Ornis Consult 2002). Thus, it can be assumed that most birds do not come close to the area swept by the rotors of wind turbines (assuming a maximum turbine height of about 120 m), so that collisions might rarely occur despite the comparably low manoeuvrability by Eagles. (Note: This might be completely different at breeding sites of Eagles, as known from wind farms in Europe; see Bevanger et al. 2008, Bevanger et al. 2010)

According to the relatively high number of Griffon Vulture fatalities in Spanish wind farms indicating no distinct avoidance behavior, a relevant collision risk at wind farms in the project area can be expected for Egyptian Vulture in spring, too. Egyptian Vultures mostly fly passively, strongly depending on thermals and thus belong to species being most vulnerable to collisions. Relevant numbers of this species have been recorded in the project area in spring 2016 and 2017 (Tables 4.40 and 4.41) and in the ACWA area in spring 2016 (Table 4.43).

Moreover, a significant collision risk at wind farms in the project area cannot be excluded for three other species of raptors (Black Kite, European Honey Buzzard and Levant Sparrowhawk) and for Great White Pelican and White Stork (and possibly Black Stork, too). As relevant numbers of these species were recorded in the project area in spring 2016 and 2017, birds might come into the range of the rotors and might face the risk of collision. However, the particular migration behaviour of Great White Pelican and White Stork might decrease collision risk at wind farms: Both species mainly migrate in larger flocks. Larger flocks seem to avoid wind turbines at greater distances and, thus, avoid critical situations. Yet if a flock does enter a wind farm, a large number of casualties can be expected.

As Harriers mainly migrate by active flight, wind turbines are not believed to have a significant adverse effect. In fact, in different wind farms in the United States, no (or only very few) fatalities were recorded for Northern Harrier (Sterner et al. 2007). From 1989 to present in Europe only 100

Harriers were found after collision with a turbine (Dürr unpubl., December 16th, 2015). Bearing in mind that migration of Harriers is not concentrated to certain areas additional mortality caused by wind turbines in the project area is not believed to have population effects on these species.

Furthermore, it is unlikely that wind turbines within the project area will affect populations of Falcons, because these species are very active fliers and migrate on a broad front and thus are not concentrated within the study area.

Migrating Common Cranes are not susceptible towards collisions with wind turbines (Grünkorn et al. 2016, Steinborn & Reichenbach 2011) and thus it seems unlikely that mortality caused by wind turbines have an effect on the population.

To conclude, bearing in mind the uncertainty of predictions and the critical conservational status of some species, establishing wind farms in the project area might include a notable risk potential for some populations. This assessment is valid for every individual wind farm within a given FiT-plot, because nameable numbers of certain species (clearly exceeding 1 % of the flyway population, see Tables 4.40 to 4.44) are expected to occur even in single plots. Furthermore, the investigation do not support the assumption of the existence of preferred flight paths that are regularly (i.e. every spring) used or of certain areas with lower migratory activity. Consequently, no spatial differentiation can be made when describing and assessing migratory activity in the project area in spring.

Hence, for each individual wind farm within the project area appropriate mitigation measures and a thorough post construction-monitoring are required to reduce the risk of collision to an acceptable level. Appropriate mitigation measures are described in Chapter 6.4.2.2. An initial assessment of cumulative impacts of multiple wind farms within the project area on large soaring birds is given in Chapter 5.5.3.1.

5.3.4.1.4 Predicting and Assessing the Weight of Barrier Effects for Migrating Soaring Birds

While avoidance behaviour reduces collision risk, it could result in wind farms acting as barriers to bird movement (e.g. Drewitt & Langston 2006).

Migrating soaring birds might change horizontal flight direction in order to avoid a wind farm or multiple wind farms in the project area. This would obviously lead to additional energy expenditure. One cannot absolutely exclude that an additional flight over a distance of, for instance, about 10 km decreases the fitness of individuals (especially when already weakened), but considering the efforts of migration it seems unlikely that this will have a relevant adverse effect on a number of birds, for instance:

- White Storks need between 8 to 15 weeks to cover a total distance of 10,000 km or more between breeding and wintering area. The average length of daily migration varies between 150 and 300 km.
- In Israel, Egypt and Sudan, average distance of daily migration of two tracked Lesser Spotted Eagles was 207 km (Meyburg et al. 2001). For the entire northward migration (more than 8,000 km) it took a bird about 8 weeks. The average daily flight distance of Lesser Spotted Eagles varies between 144 km and 214 km per day (Meyburg et al. 2004b).

Furthermore, Meyburg et al. (2002) recorded an adult female of Lesser Spotted Eagle that initially migrated to the southern point of the Sinai Peninsula in 1997. One day after arrival it changed direction and flew 280 km northwest along the eastern coast of the Red Sea straight to Suez. In 1998 it repeated the detour to the southern tip of the Sinai Peninsula and back north to Suez. The reasons why the bird did not cross the Gulf from the southern tip of Sinai (which is about 66 km wide at this point) but took a detour of 500 km, remained unclear.

- Meyburg et al. (2012) tracked 15 Steppe Eagles, which were fitted with satellite transmitters between 1992 and 1997. The study revealed average daily migration distances during spring between 100 km and 195 km. The largest average daily flight distance among all tracked individuals was approximately 355 km.
- Extremely long stretches were recorded of an Egyptian Vulture that flew through southwest Egypt, northwest Sudan and northeast Chad a total of 1,017 km in two days (Meyburg et al. 2004a). The average migration path within another period of seven days was 185 km per day.

Thus, an additional flight path of about 10 km or even more seems unlikely to have a relevant impact on a bird's fitness. Moreover, there is no need to assume that an additional flight path would be covered unexceptionally by active flight, consuming much more energy than gliding.

Another option to avoid a wind farm in the project area is to change altitude (mostly by increasing) and subsequently to migrate above the critical zone of the wind turbines. Thermals are not believed to be a limiting factor at the Red Sea coast. There should be a number of vertical air currents allowing birds to gain altitude. Hence, there is no reason to assume that increasing altitude will only be accomplished by active flight (causing additional energy expenditure).

Since weather conditions (especially wind speed and direction) should be nearly the same in the project area and its surrounding, it is not expected that birds will face additional headwinds or other unfavourable conditions as a consequence of avoiding a wind farm.

To conclude, although the degree of additional energy expenditure cannot be estimated precisely, it seems unlikely that avoidance behaviour might produce a significant effect on populations (see also Masden et al. 2009).

5.3.4.1.5 Synopsis – Final Assessment of the Expected Impacts on Migrating Soaring Birds

First of all one must acknowledge that much information has been gained in the last years and meanwhile there exists an extensive understanding on migration of large soaring birds at the Red Sea coast. However, there is still a huge lack of knowledge with regards to the behaviour of large soaring birds approaching a large operating wind farm. Consequently, every impact assessment still remains in a way uncertain calling for an application of the precautionary principle. So, bearing in mind the uncertainty of predictions, the high importance of the area for migrating soaring birds in spring and the critical conservational status of single species, operation of wind farms might include a notable risk potential for certain species.

As given in Chapter 5.1, the significance of an impact can be assessed as a function of “event magnitude” and “receptor sensitivity”.

The results obtained in 2016 (and those gained by other studies in 2015) clearly show that neither the project area nor single FiT-plots are of particular importance for bird migration in autumn (Chapter 4.3.4.3). Over vast periods of the autumn season migratory activity of relevant species was low. Remarkable migratory activity was restricted to single days and mainly referred to larger flocks of three species (European Honey Buzzard, White Stork and Great White Pelican made up about 98 % of all recorded birds). None of these species is considered as to be threatened or near threatened. Hence, “receptor sensitivity” is assessed to be low.

Due to the lack of knowledge the magnitude of collision risk can hardly be assessed. Applying the precautionary principle, collision risk at a single wind farm in the project area during autumn migration is regarded as medium leading to a minor impact on large soaring birds (Figure 5.3).

The magnitude of a barrier effect of a single wind farm is regarded as low, because population of target species are unlikely to be affected. Consequently, any impact caused by barrier effects on large soaring birds is negligible in the autumn season (see Figure 5.4).

As given in Chapter 4.3.4.4, the results obtained in 2016 and 2017 clearly show that the project area (and even single FiT-plots) is of high importance for migration of large soaring birds in spring. Some species recorded in the project area are of international conservational concern and / or their number represents a significant proportion of their flyway population. Hence, “receptor sensitivity” is assessed to be high.

This is in accordance with an initial assessment obtained by a “Sensitivity Search” with the Soaring Bird Sensitivity Map Tool that has been developed by BirdLife International (see Annex VII). According to the Sensitivity Map a total of 19 soaring bird species were observed migrating over the desert plains northwest of Ras Ghareb and a further 11 soaring bird species are thought to occur in this area (see Annex VII). On that background the “combined sensitivity” of the area northwest of Ras Ghareb is assessed by the Tool as “outstanding” expecting considerable impacts on populations of large soaring species when developing wind farms in this area.

Due to the lack of knowledge the magnitude of collision risk can hardly be assessed. Applying the precautionary principle, collision risk at a single wind farm in the project area during spring migration is regarded as medium to high leading to a major (significant) impact (Figure 5.4). Hence, even for a single wind farm within the project area appropriate mitigation measures and a thorough post construction-monitoring are required to reduce the risk of collision to an acceptable level (Chapter 6.4.2.2)

The magnitude of a barrier effect of a single wind farm is regarded as low, because population of target species are unlikely to be affected. Consequently, any impact caused by barrier effects on large soaring birds is moderate in the spring season (see Figure 5.5).

An initial assessment of cumulative impacts of multiple wind farms within the project area on large soaring birds is given in Chapter 5.5.3.1.

		Autumn migration		
		Sensitivity		
Single wind farm		Low	Medium	High
	Magnitude of effect	Low	Barrier effect	
Medium		Collision risk		
High				

Figure 5.4: Impact matrix to assess the effects of an individual wind farm in the project area on migrating birds in autumn (negligible, minor, moderate, major)

		Spring migration		
		Low	Medium	High
Magnitude of effect	Low			Barrier effect
	Medium			Collision risk
	High			

Figure 5.5: Impact matrix to assess the effects of an individual wind farm in the project area on migrating birds in spring (negligible, minor, moderate, major)

5.3.4.2 Predicting and Assessing Possible Impacts on Roosting Birds

Construction phase

Construction of large wind farms in the project area might lead to:

- Modification or a loss of habitat for roosting birds by using areas for foundations of turbines, permanent access roads, storing positions for heavy machines, other technical installations etc.

The area was rarely used by roosting birds and does not hold a preferred roosting site. Moreover, the area required for infrastructural elements is comparatively small in relation to a single FiT-plot and - all the more - in relation to the whole project area. Thus, even after construction of wind turbines birds will find sufficient opportunities for roosting inside, but predominantly outside wind farm areas. Consequently, modification or a loss of habitat caused by large wind farms in the project area is assessed as a minor impact on roosting birds.

- Disturbance by human activities with heavy machines, traffic, noise and dust emission

The area was rarely used by roosting birds and does not hold a preferred roosting site. Large soaring birds mostly spend one night in the desert only, while smaller birds (mainly songbirds) might spend more than one day at one of the few vegetated spots. Thus, songbirds might temporarily be affected by disturbance during the construction phase. However, disturbance effects are restricted to a small area and appear only temporarily. Consequently, disturbance by human activities during the construction phase is assessed as a minor impact on roosting birds.

- Attraction of roosting birds if areas with garbage, open waters or houses with vegetation are constructed

Increasing numbers of birds within the area can elevate the risk of collision during turbine operation. Thus, attracting birds should be avoided, both during construction and operation of wind farms. Accordingly, garbage should be removed directly from wind farm areas. Open water areas or houses with vegetation should not be built within and in the vicinity of wind farms. Considering these mitigation measures collision risk at wind farms in the project area is assessed as a minor impact on roosting birds.

To conclude, no significant impact on roosting birds is expected during the construction phase of large wind farms in the project area.

Operation and Maintenance Phase

Operation and maintenance of large wind farms in the project area might lead to:

- Disturbance by operational turbines leading to a decrease in habitat quality or a total habitat loss
Roosting birds might be affected by disturbance during the operational phase of wind farms in the area. It is well known that species which tend to roost in larger flocks avoid operational wind turbines. Therefore, Great White Pelicans and White Storks will probably not roost within a wind farm area. Other species roosting in small flocks or even singularly, e.g. birds of prey or songbirds, are not known to avoid wind turbines.

The area was rarely used by roosting birds and does not hold a preferred roosting site. Moreover, even after construction of large wind farms there remain undisturbed areas that can be used for roosting by birds. Consequently, disturbance by operation of turbines is assessed as a minor impact on roosting birds.

- Disturbance by human activities related with maintenance of wind farms

The area was rarely used by roosting birds and does not hold a preferred roosting site. Large soaring birds mostly spend one night in the desert only, while smaller birds (mainly songbirds) might spend more than one day at one of the few vegetated spots. Thus, songbirds might temporarily be affected by disturbance during the operation and maintenance phase. However, disturbance effects are restricted to a small area and appear only temporarily. Consequently, disturbance by human activities is assessed as a minor impact on roosting birds.

- Collision risk

Roosting birds face the risk of collision at operating turbines. Collision risk might be high in situations when larger flocks of birds i) stop migration in the afternoon to look for a place to spend the night or during bad weather conditions and ii) start migration in the morning after having spent the night in the desert. However, the area was rarely used by roosting birds and does not hold a preferred roosting site. Moreover, species roosting in larger flocks usually avoid wind farm areas and will not roost in the vicinity of turbines. Hence, collision risk at wind farms in the project area is assessed as a minor impact on roosting birds.

- Attraction of roosting birds if areas with garbage, open water or houses with vegetation are constructed

Increasing numbers of birds within the area can elevate the risk of collision during turbine operation. Thus, attracting birds should be avoided, both during construction and operation of wind farms. In doing so, collision risk at wind farms in the project area is assessed as a minor impact on roosting birds.

To conclude, no significant impact on roosting birds is expected during the operation and maintenance phase of large wind farms in the project area.

5.3.4.3 Predicting and Assessing Possible Impacts on Local Birds

Construction phase

Construction of large wind farms in the project area might lead to:

- Modification or a loss of habitat for local birds by using areas for foundations of turbines, permanent access roads, storing positions for heavy machines, other technical installations etc.

The local bird community is very poor in species and, moreover, bird density is very low. Moreover, the area required for infrastructural elements is comparatively small in relation to a single FiT-plot and - all the more - in relation to the whole project area. Thus, even after construction of wind turbines birds will find sufficient opportunities for breeding and foraging

inside and outside wind farm areas. Consequently, modification or a loss of habitat caused by large wind farms in the project area is assessed as a minor impact on local birds.

- Disturbance by human activities with heavy machines, traffic, noise and dust emission

Local birds, such as Sandgrouse, Larks or Falcons, might be affected by disturbance during the construction phase. However, disturbance effects are restricted to a small area and appear only temporarily. Local birds can find alternative habitats for the time of constructional works and can reoccupy all areas afterwards. Consequently, disturbance by human activities during the construction phase is assessed as a minor impact on local birds.

- Attraction of local birds if areas with garbage, open water or houses with vegetation are constructed

Increasing numbers of birds within the area can elevate the risk of collision during turbine operation. Thus, attracting birds should be avoided, both during construction and operation of wind farms. Accordingly, garbage should be removed directly from wind farm areas. Open water areas or houses with vegetation should not be built within and in the vicinity of wind farms. Considering these mitigation measures collision risk at wind farms in the project area is assessed as a minor impact on local birds.

To conclude, no significant impact on local birds is expected during the construction phase of large wind farms in the project area.

Operation and Maintenance Phase

Operation and maintenance of large wind farms in the project area might lead to:

- Disturbance by operational turbines leading to a decrease in habitat quality or a total habitat loss
Local birds, such as Sandgrouse, Larks or Falcons, might be affected by disturbance during the operational phase. However, most species (as resident birds) are known to be unsusceptible to the nearly constant acoustic and visual stimuli of wind turbines. In addition, local bird community is very poor in species and, moreover, bird density is very low. Consequently, disturbance by operation of turbines is assessed as a minor impact on local birds.

- Disturbance by human activities related with maintenance of wind farms

Local birds, such as Sandgrouse, Larks or Falcons, might be affected by disturbance during the operation and maintenance phase. However, disturbance effects are restricted to a small area and appear only temporarily. As the local bird community is very poor in species and as bird density is very low, disturbance by human activities during the operation and maintenance phase is assessed as a minor impact on local birds.

- Collision risk

Local birds will face the risk of collision at operating wind turbines. However, resident birds are aware of turbines and their behaviour might be better adapted to the presence of these infrastructures. As the local bird community is very poor in species and as bird density is very low, collision risk at large wind farms in the project area will not lead to adverse population effects and is, thus, assessed as a minor impact on local birds.

- Attraction of local birds if areas with garbage, open water or houses with vegetation are constructed

Increasing numbers of birds within the area can elevate the risk of collision during turbine operation. Thus, attracting birds should be avoided, both during construction and operation of wind farms. In doing so, collision risk at wind farms in the project area is assessed as a minor impact on local birds.

To conclude, no significant impact on local birds is expected during the operation and maintenance phase of large wind farms in the project area.

5.4 Social Environment

5.4.1 Settlements, Land Use and Existing Infrastructure

Due to the large distance no settlement will be directly adversely affected by wind farm developments in the project area. This is valid with regard to noise, shadowing from turbines and also with regard to landscape deterioration.

Considering the positive effects of wind power development in such area creating employment (e.g. labour for construction works, guarding of construction and of wind farm operation side and strengthening the infrastructure), it can be concluded that the project will lead to positive effects for the settlement of Ras Ghareb.

Since the project site is uninhabited and unutilized, the project is not expected to have any direct socio-economic impacts (e.g. physical or economic displacement, access to resources, etc.). The only human presence near the project site is that of the neighboring oil concessions. The workers are mostly from other governorates (mostly Cairo and Suez), only a few workers are from Ras Ghareb city (see SEP for more details). These workers do not utilize the project site in any way. In addition, no Bedouin settlement exists and nomadic groups live at or near the project site. The only members of the Bedouin communities who have been met near the site during site visits and interviews were workers of the the oil companies. Thus, there are no traditional or untraditional uses of the project site (e.g. herding or any other activities

As given in Chapter 4.4.2, there is very limited land-use within the project area: two roads controlled and used by petrol companies, a 220 KV overhead powerline (OHL) at the eastern border of the project area, single tracks designed for wind farm developments and tracks of 4-wheeled cars. The function of these infrastructures will not be affected by the construction and operation of wind farms in the area. There are no other human activities, no land use or other elements in the project area that might be adversely impacted by wind farm developments and associated infrastructure.

The land take by wind power projects is very limited (usually less than 2 % of the overall area) leaving most of the area free from any interventions. The area requirement will be only marginally increased during the construction phase due to temporary additional working areas, construction yards and storage facilities. Hence, future land use (e.g. solar power) or development of other activities will not be significantly restricted by the project

Negative effects on land use throughout the construction, operation, maintenance and decommission phases are expected to be negligible to low adverse.

Wind farm developments in the area will have positive impacts to the infrastructure, because the existing infrastructure would be even strengthened by reinforcement and extension of access roads and electricity supply inside and in the periphery of the project area.

Accordingly, no relevant adverse impact on land-use and existing infrastructure in the region is expected.

5.4.2 Impact on Traffic and Utility Services

It can be expected that construction activities for wind farm developments will result in an increase in vehicular traffic including movement of construction vehicles, plant and equipment as well as any

necessary traffic on adjacent roads and lanes, such as the delivery of turbines onto the site. The project area can be reached from the Suez-Hurghada road. This road has sufficient strength and width and would be suitable for heavy transport. To conclude, as the main roads in the overall region are very well dimensioned at low traffic frequency there are not any critical impacts on the traffic on public roads during construction or decommission phase.

A considerable amount of water might be required for concrete making for turbines, pylons and buildings, if the concrete will not be provided as ready mix. In case of having a batching plant at the site the water will have to be provided by tankers. The amount of fresh water required per day can be estimated using the case of making a large size 250 m³ concrete foundation. Accordingly the maximum daily fresh water use is about 35 m³ of fresh water to be supplied by tanker from regional sources or the water supply system of Ras Ghareb fed by the Nile water. Some more water would be required in case of simultaneous casting of foundations for a substation, which however are significantly smaller. With a maximum demand of 50 m³ fresh water per day the nearby water supply systems might already be stressed. If that water cannot be provided from the public utility sources it must be procured from the Nile Valley by tankers, what is still manageable.

There will be no water demand of wind farms themselves during operation. Some water demand may arise from the sanitary facilities of staff building and substation (about 1 m³/d). The facilities might be connected to the regional water supply originating from the Nile via Hurghada. The expected amount of water consumption will not be critical for the supply of the region.

5.4.3 Social and Economic Environment

5.4.3.1 Employment and Economic Effects

The crude oil exports is one of the national income of Egypt, therefore fuel saving can provide an increase in the national income by providing foreign currency due to oil exportation.

Wind farm developments in the project area will significantly lead to an increase of job opportunities in the region and, thus, will help solving the unemployment problem and positively affecting the general economic situation in Egypt. For instance, as a consequence of the implementation of Zafarana wind farms a new community has been established in the vast desert area enhancing local migration of population from the Nile Valley to the Gulf of Suez. This is still a problem of population distribution in Egypt.

Construction of wind farms (incl. associated infrastructure) will have economic benefits for workers in Egypt usually mainly coming from Upper Egypt but also from other regions. One can expect that:

- About 30 to 40 % of the investment volume (e.g. towers, cables, civil works, electrical works, services) would be produced locally.
- During construction local personnel will (shall) be employed for civil, electrical and installation works. The works will be carried out essentially by Egyptian companies.
- Local Bedouins are usually employed as guards, as the example of Zafarana wind farms shows. Accordingly, Bedouin families living in the Red Sea area, will (shall) directly benefit from the project.

During the construction period (construction, commissioning and later decommissioning) the following jobs are expected to be created (based on statistical data gained by the Consultant's experiences in projects all over the world):

- 6 annual jobs per installed MW
- 0.4 to 0.8 yearly jobs per MW for equipment removal at the end of its lifespan
- approx.. 470,000 Euro per MW added value during plant construction

Considering the unemployment rate in Egypt the demand for construction workers would not create labour bottlenecks in other areas.

Operation and maintenance for wind farm developments will (shall) be carried out by local personnel. Accordingly, a significant number of electricians, mechanics, engineers and workers will (shall) be employed for such services.

During the operation and maintenance period the following jobs are expected to be created (based on statistical data gained by the Consultant's experiences in projects all over the world):

- 0.54 permanent jobs per installed MW for maintenance and repair
- approx. 55,000 Euro yearly per MW added value
- lifespan of the wind turbines is approx. 20 years

Transmitted wind power utilization, especially at a site with very high wind energy potential like the project area, is very competitive, if compared to international level of cost of energy. It saves indigenous gas and oil reserves, which alternatively could be exported at world market prices.

The additional energy yield of wind farms in the project area will assist in meeting the increasing electricity demand in Egypt. Indirect benefits could accrue due to increased capacity by new wind farms to provide reliable electricity supply to existing facilities, as well as electricity for new developments (including residential, commercial and industrial developments). This impact will be positive and is anticipated to be of significance at the national level, particularly with no CO₂ emissions and less environmental impacts of the wind based electricity generations.

To conclude, wind farm developments in the project area will have significant positive socio-economic effects.

5.4.3.2 Occupational Health and Safety Risks

Potential occupational health and safety hazards during the construction of wind farms and the associated infrastructure might include risks from

- earth works and concrete works such as foundation constructions (minor risks);
- working at heights (major risks);
- loading and de-loading of bulky equipment (minor risks);
- electrical works (partly under control by external authority EETC).

Health and safety risks shall be controlled at least as to the level defined in the Environmental, Health and Safety Guidelines, Wind Energy (IFC 2007). In addition, relevant occupational health and safety standards to be considered during the construction of the project include

- keeping workplace standards with regard to air quality, noise and temperature, as defined by Law 4/1994 and its executive regulations, Annex 8;
- keeping the Egyptian code of practice as well as the stipulations of the Labor Law 12/2003 for ensuring strict procedures for de-energizing and checking electrical equipment and the implementation of a safety supervision scheme before maintenance as well as the performance by trained personnel only;
- keeping general health and safety standards such as
 - o personnel using special protection such as safety boots, helmet, and, as to the kind of work, gloves, masks or eye protection glasses;
 - o adequate sanitary facilities free from pathogens and suitable for washing of personnel;
 - o safety training and safety equipment (safety belts) for working at heights;

- o elevated platform, stairs, walkways or ramps to be equipped with handrail and non-slip surfaces;
- o periodical medical examinations for personnel working at heights;
- o establishment of health and safety plans and assignment of health and safety engineer for supervision; and
- o periodical safety instructions, etc.

In the event that the aforementioned measures are implemented, health and safety risks during construction and decommission phase will be limited to an acceptable level.

Potential occupational health and safety risks during the operation and decommissioning phase of the project are similar to those during the construction phase. No relevant health and safety risks are expected, if a health and safety programme will be established and properly executed.

5.4.3.3 Other Socio-Economic Effects

Wind farm developments in the project area will not interfere with any settlement or regional infrastructure. It will lead to an employment of limited numbers of workers during construction, most of them probably coming from the region. It will have measurable effects on cultural, community and demographic impacts. It will contribute to employment and development of the region.

During the operating phase the wind farm development will contribute to employment, avoidance of greenhouse gas emissions and saving of indigenous resources.

No negative socio-economic effects are expected. In contrary wind power development in the project area is likely to have positive impacts on employment and the social and economic development in Egypt with a focus on the project region itself.

5.4.3.4 Domestic and Hazardous Waste Management

Construction and Decommission Phase

Considerable amounts of solid waste will be generated during the construction and decommission phase of wind power projects and associated infrastructure. The waste essentially consists of packing material (paper, plastics, wood) for transport of the turbine and of auxiliary equipment components. The waste will occur mostly at the individual turbine / pylon erection sites and in the construction yard. Under the heavy wind conditions the waste is easily spread over the desert and transported over large distances.

The only possible source for hazardous waste caused during construction and decommission is spilled oil and grease originating from construction equipment (e.g. trucks, excavators, craned) and from handling and commissioning of deliveries (e.g. transformer or gear box oil, hydraulic oil).

Both, the littering of waste and the spillage of hazards can easily be avoided by proper workmanship and strong supervision.

Operation and Maintenance Phase

Waste from wind farms during operation would consist of used consumables regularly to be exchanged, when servicing the machines, and smaller defective parts. These are non-hazardous materials, most of them valuables and fit for recycling. Larger defective parts such as gear box or generator would anyhow be returned to the factory for repair or re-use of materials.

Hazardous used oil will be collected once per year or once in two years and send for recycling. The practice in other Egyptian wind farm shows that this works without problems. The volume of used oils will depend on the service intervals requested by the selected contractor.

Domestic waste will be generated at the service facilities and the 220 / 22 kV substations. Experience gained in Zafarana wind farms shows that the domestic waste is small in quantities and mainly composed of biodegradable or burnable waste. The standard method of waste disposal as applied in Zafarana or at remote housing facilities in the desert in Egypt would be that waste will be collected in bags and in bins and disposed of on an environmentally safe waste disposal site (desert pits).

Thus, no significant adverse impacts caused by domestic and hazardous waste are expected if a proper workmanship and domestic waste management scheme will be applied.

5.4.4 Noise, Vibrations, Electromagnetic Interferences, Light Reflections and Shadowing

5.4.4.1 Noise

The Law 4/1994, executive regulations, Annex 7, require maintaining the following critical ambient noise levels at day (7 am to 6 pm) and night times (10 pm to 7 am):

Receptor	Day dB (A)	Night dB (A)
Industrial areas (heavy industries)	70	60
Commercial & downtown	65	55
Mixed Residential, commercial, small industrial	60	50
Residential areas in cities	55	45

The existing noise receptors inside and in the surrounding of the project area were identified and assigned to the relevant receptor cluster, whereby the Ras Ghareb settlement is far away from the project area. Based on the noise requirement several clusters were created in the noise model (see Figure 5.6).

Construction phase

Noise emissions during construction phase originate from the use of transport equipment and other machine, most of them with quite limited specific noise emissions. The frequency of transports is very limited and may peak to 30 per day even in case of larger wind farm construction sites. The machinery will work decentralised at individual wind turbine erection places and are single noise emission sources. The maximum noise emission that can be expected during the construction phase should originate from the use of heavy earth work equipment at the site such as excavator or front loader, but especially from jack hammering in case of compacted or rocky underground. Considering that the construction places are at big distances to the next settlements outside the area boundaries, no significant noise impacts from the temporary construction activities on receptors are expected.

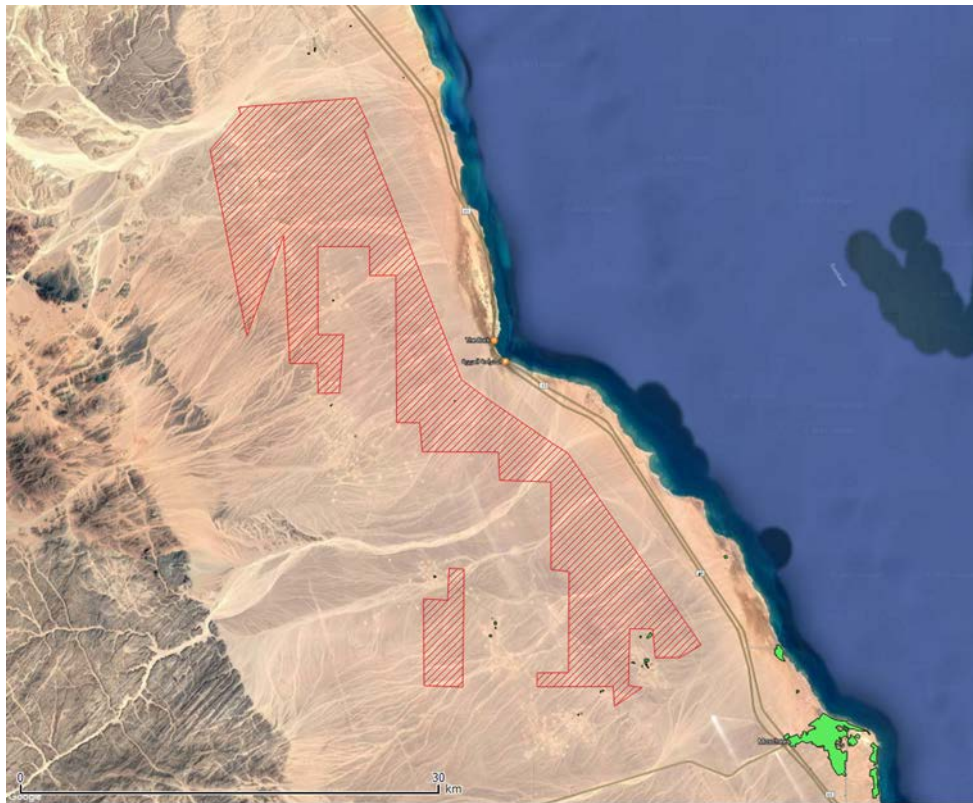

Figure 5.6: Noise receptors in the wider surrounding of the project area (due to the size of clusters, most receptors are not clearly shown in the map, except Ras Ghareb)

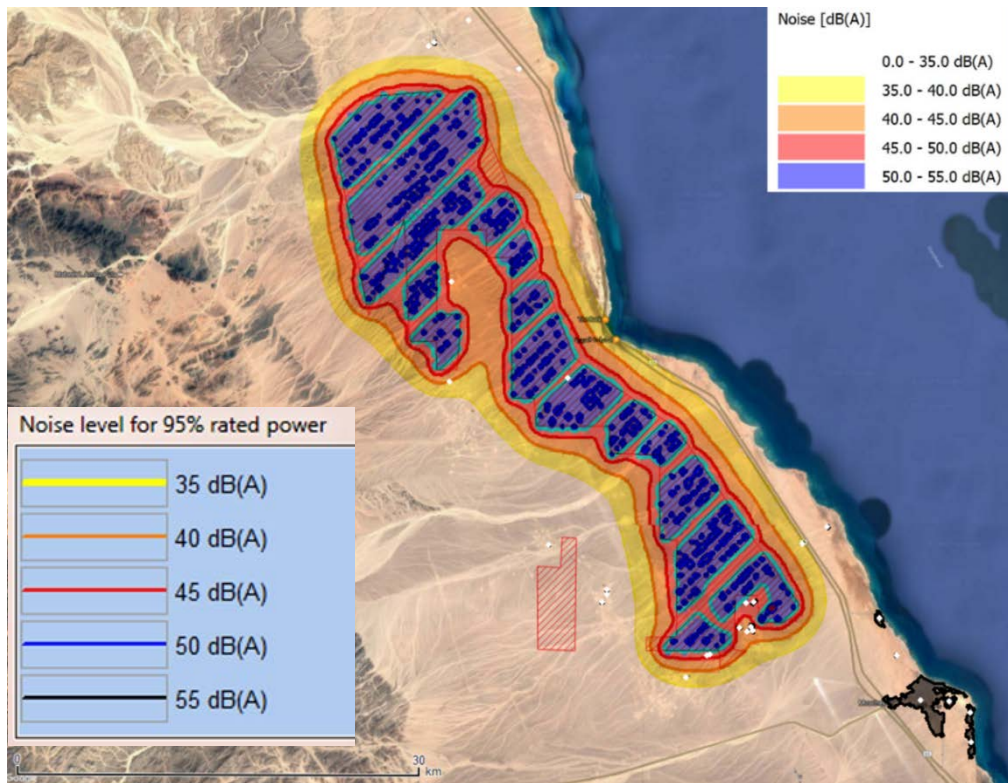

Figure 5.7: Noise propagation calculation results at wind farm boundary area superposed on google earth satellite image (test configuration)

Operation and Maintenance Phase

Noise propagation from the wind farm was checked by using commercial software. The calculation was exemplarily carried out considering the noise calculation standard ISO 9613-2 with a typical 2 MW or 2 MW-plus wind turbine types. Wind farm configuration with the Vestas V80 with a hub height of 78 m and the noise emission level was on basis of "Mode 0" at 100 % of rated power. For the calculation a condensed wind farm configuration was used to consider an accumulation of noise levels. The configuration used is just exemplary and does not consider potential siting restrictions.

The ambient noise level of 45 dB (A) (noise limit for residential areas) is already achieved at distances of about 300 m to WTGs (corresponds to the circle radius around WTGs). Even the lowest defined ambient noise level of 35 dB (A) is achieved at about 1.5 km distance, while the first settlements of the outskirts of Ras Ghareb are located at about 8 km from the far-south wind turbines (see Figure 5.7). Thus, there is not any contribution of wind farms to the noise level in settled areas.

5.4.4.2 Vibrations

Vibrations result from wind turbine operation. However, turbines working under regular conditions with blades correctly balanced and the main shaft correctly adjusted show very little vibration. The propagation of the vibration is dampened by the foundation body and there is very little transmission into the underground, especially in case of a non-rocky underground like in most parts of the project area. Thus, vibration effects will not be measurable in the underground already nearby the wind turbines. Moreover, vibrations or very low-frequency "infrasound" produced by wind turbines are the same as those produced by vehicular traffic and home appliances and are similar to the beating frequency of people's hearts. Such "infrasounds" are not special and convey no special risk factors.

5.4.4.3 Electromagnetic Interferences

Wind turbines could potentially cause electromagnetic interference with aviation radar and telecommunication systems (e.g. microwave, television and radio). This interference could be caused by three main mechanisms, namely near-field effects, diffraction, and reflection or scattering. The nature of the potential impacts depends primarily on the location of the wind turbine relative to the transmitter and receiver, characteristics of the rotor blades, signal frequency receiver, characteristics and radio wave propagation characteristics in the local atmosphere (see IFC 2007).

A military radar is operated south of the project area. As the area was already cleared by the Ministry of Defense before being assigned for wind power development by presidential decree, it can be assumed that no interference with wind farm developments is expected. This may be due to the distance to turbines or the fact that the radar is not focusing on northern sectors. Vice versa it can be expected that the radar will not have negative impacts on the electronic system of wind turbines (e.g. top controller).

One mobile phone telecommunication mast and one radio link mast are placed at the Ras Ghareb-El Shaikh Fadel road southwest of the project area. Due to the large distance of at least 9 km wind farm developments should not block any signal from any directional transmitters.

Under consideration of keeping sufficient corridors and safety distances no relevant adverse impact on electromagnetic systems such as radar, telecommunication and television broadcast is expected.

5.4.4.4 Light Reflections and Shadowing

The blade coating of modern turbines does usually absorb direct sun light and, thus, reflection does not cause any environmental impact. In case of wind farm developments in the project area a special

blade coating (black and white aviation marking) shall apply to increase the visibility to the birds. Thus reflection characteristics would be increased. However, in any case, due to the absence of receptors in the surrounding of the wind farm that can be affected by reflection, there is no critical impact from that.

The critical impact of shadowing (flickering) as per acceptable standards is 30 hours per year and 30 minutes per day. This can be achieved only at places near to wind turbines, where the observed transition time of the sun through the rotor diameter can achieve such durations. As there are no residences or housing near to the turbines, it is obvious that there is no impact from flickering beyond acceptable level.

5.4.5 Archaeological, Historical and Cultural Heritage

In the absence of archaeological, historical and cultural heritages within the projects area or in its wider surrounding no adverse impact caused by wind farm developments is expected.

5.5 Cumulative Impacts

5.5.1 Definition, Difficulties and Restrictions

Cumulative impact assessment focusses on environmental and/or socio-economic effects that may not on their own constitute a significant impact, but may result in larger/more significant impacts when combined with impacts from existing or reasonably foreseeable future activities.

According to the IFC Handbook (2015, p. 19) "Cumulative impacts may result from the successive, incremental, and/or combined effects of an action, project, or activity [...] when added to other existing, planned, and/or reasonably anticipated future ones." Cumulative impact assessment (CIA) is important, because an effect of a single project might be assessed as negligible or insignificant, but it might contribute to a significant impact in combination with other projects – either by increasing the magnitude of a certain effect (e.g. additional visual impact on the landscape character) or even by creating a new type of effect, i.e. an effect with a new quality (e.g. two projects acting as a barrier for bird migration).

A challenge in the completion of a CIA is determining the likelihood that other plans will be implemented or other projects will be constructed and making the required data for these plan and projects available. Only projects which i) are already operating, ii) are under construction and iii) will be constructed before or simultaneously to the proposed plan or project should be considered. However, the sequence in which plans / projects will be implemented is often not clear. Nevertheless, for the CIA it is essential to come to a reliable and final decision about the projects to be considered. Furthermore, all details of the projects (in case of a wind farm: mainly number, type and location of turbines, details on support infrastructure) to be considered have to be available to ensure a thorough CIA. Accordingly, it is stated in the IFC Handbook (2015, p. 9) that "CIA processes involve continuous engagement with affected communities, developers, and other stakeholders. In practice, effective design and implementation of complete CIA processes is often beyond the technical and financial capacity of a single developer. CIA thus transcends the responsibility of a single project developer. On occasion, it may be in the best interest of a private sector developer to lead the CIA process, but the management measures that will be recommended as a result of the process may ultimately be effective only if the government is involved".

Another challenge arises from the uncertainty of predictions, e.g. as it is still difficult to give a founded estimate on the number of collision victims at a single wind farm (the low value of collision

risk models is discussed in Chapter 5.3.4.1.2), the assessment of cumulative collision risks at different wind farms in a region can hardly be assessed. In those cases the only reasonable approach seems to be applying worst case-scenarios and the precautionary principle.

5.5.2 Wind Farm Developments to be considered

The 284 km² area covers FiT-plots (1-1 to 9-5; see Map 5.1), each designated for a 50 MW wind farm. The cumulative impact for construction and installation of approx. 1,500 MW wind power projects is considered. No official information on the proposed wind farms is currently available (e.g. number, type and location of turbines, support infrastructure). However, assuming the usage of a turbine type with a rated output of 2.5 MW one can roughly estimate the number of turbines to be 20 turbines per 50 MW wind farm. But, due to the lack of information no realistic time schedule for installation of the FiT-wind farms can be developed. Furthermore, it is, today, even not evident how many of the FiT wind farms will be installed as there are certain restrictions (see for instance Chapter 6.4.2.2.3).

In the following different scenarios for construction and installation phases are considered.

First scenario – all FiT wind projects start construction simultaneously at the same time



The table below shows the estimated numbers of main machinery and equipment assumed to be required during construction phase.

Table 5.3: First scenario (simultaneous construction) of cumulative effects of wind farm development

Construction phase	Total for all the assumed projects
<i>Machinery and equipment</i>	
Loaders	60
Excavators	120
Graders	60
Dozers	120
Generators	90
Required trucks for excavation	450
Trucks	120
Rollers	60
Auxiliary crane for WTG foundation reinforcement	60
Transit mixture	480
Water supply truck (foundation pouring)	150
Water supply truck (curing, roads, platforms)	300
Concrete Batching plant	60
Total machinery	2,070
Total machinery and equipment	2,130

Map 5.1
Wind farm developments to be considered in the cumulative impact assessment for the project area

Project Area

-  boundaries of the project area
-  FiT-plot for 50 MW wind farm (1-1 to 9-5)
-  existing roads

● editor: Lars Gaedicke, July 31st 2017

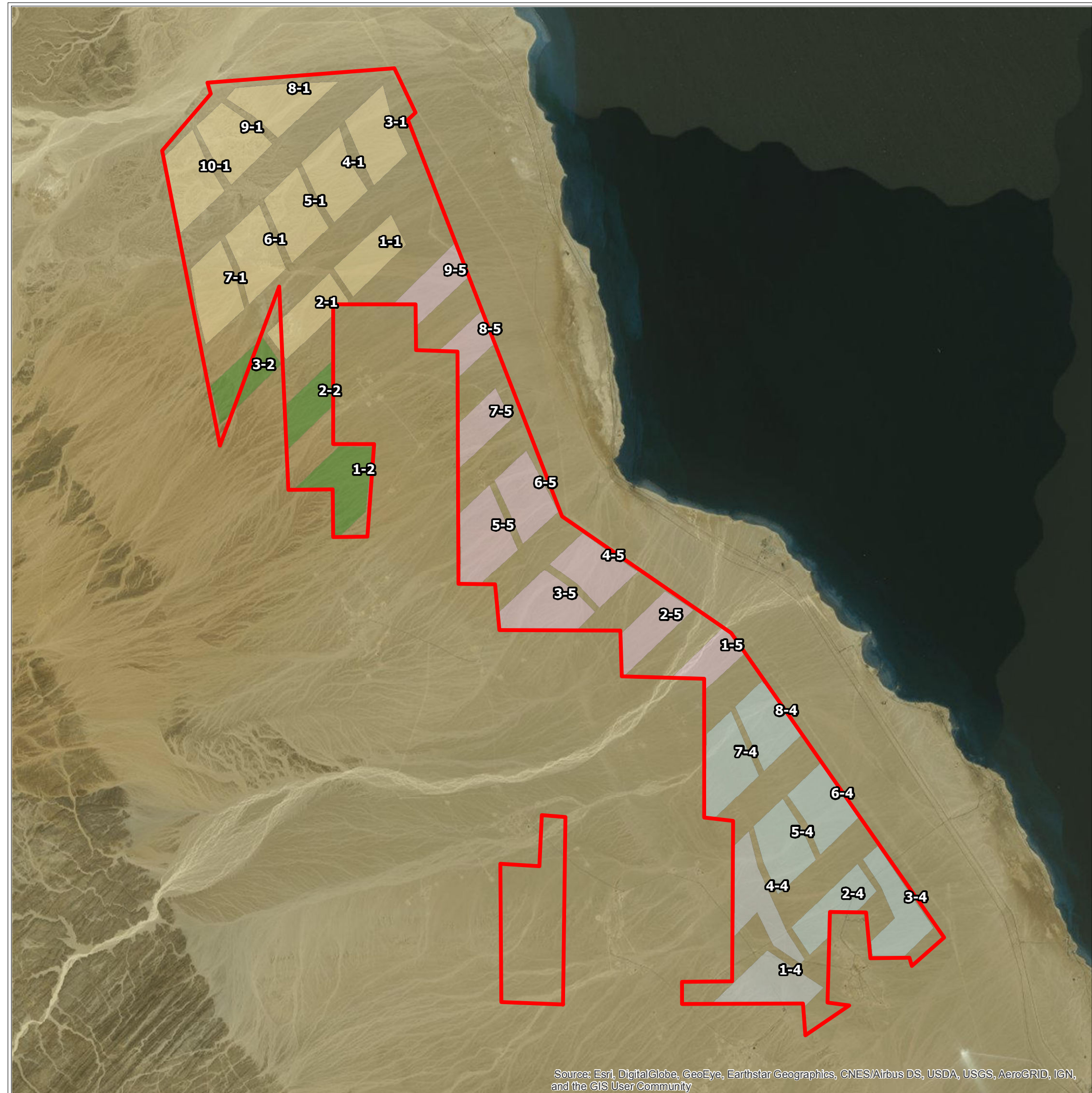
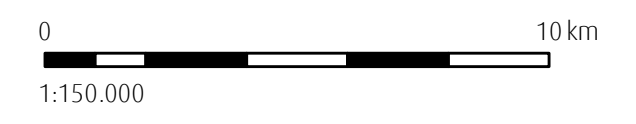

Second scenario – all FiT wind projects start erection and installation of the WTGs simultaneously at the same time

The table below shows the estimated numbers of main machinery and equipment assumed to be used during the erection and installation of WTGs.

Table 5.4: Second scenario of cumulative effect of wind farm development

WTG erection phase	Total for all the assumed projects
<i>Trucks</i>	
Trucks for WTG towers	180
Truck for nacelle	60
Truck for hub	60
Trucks for blades	180
<i>Cranes</i>	
Main crane	60
Auxiliary crane	60
Total trucks	480
Total trucks and cranes	600

The third scenario – development, construction and operation in 6 different sets

It is assumed that 6 sets of projects will be developed and subsequently constructed, installed, commissioned and operated. Each of the 6 sets is consisting of 4 to 5 FiT-projects.

Table 5.5: Third scenario of cumulative effect of wind farm development

Year	Set of projects I	Set of projects II	Set of projects III	Set of projects IV	Set of projects V	Set of projects VI
1	Development					
2	Development	Development				
3	Development	Development	Development			
4	Construction	Development	Development	Development		
5	Construction	Construction	Development	Development	Development	
6	Installation	Construction	Construction	Development	Development	Development
7	O&M	Installation	Construction	Construction	Development	Development
8	O&M	O&M	Installation	Construction	Construction	Development
9	O&M	O&M	O&M	Installation	Construction	Construction
10	O&M	O&M	O&M	O&M	Installation	Construction
11	O&M	O&M	O&M	O&M	O&M	Installation
12-26	O&M	O&M	O&M	O&M	O&M	O&M
27		O&M	O&M	O&M	O&M	O&M
28			O&M	O&M	O&M	O&M
29				O&M	O&M	O&M
30					O&M	O&M
31						O&M

According to experiences in similar large scale wind farm developments, the probabilities of occurrence of the first and second scenario are almost zero. The third scenario, in which some projects start in parallel and overlapped with other projects during the time of development, construction, installation, commissioning and operation are foreseen to be the most realistic scenario.

The graph below shows the assumed machinery and equipment necessary for the construction, installation, commission and operation and maintenance for each set of projects as well as cumulative effects of overlapping of the different stages of the projects and the assumed numbers of machinery and equipment which will be used.

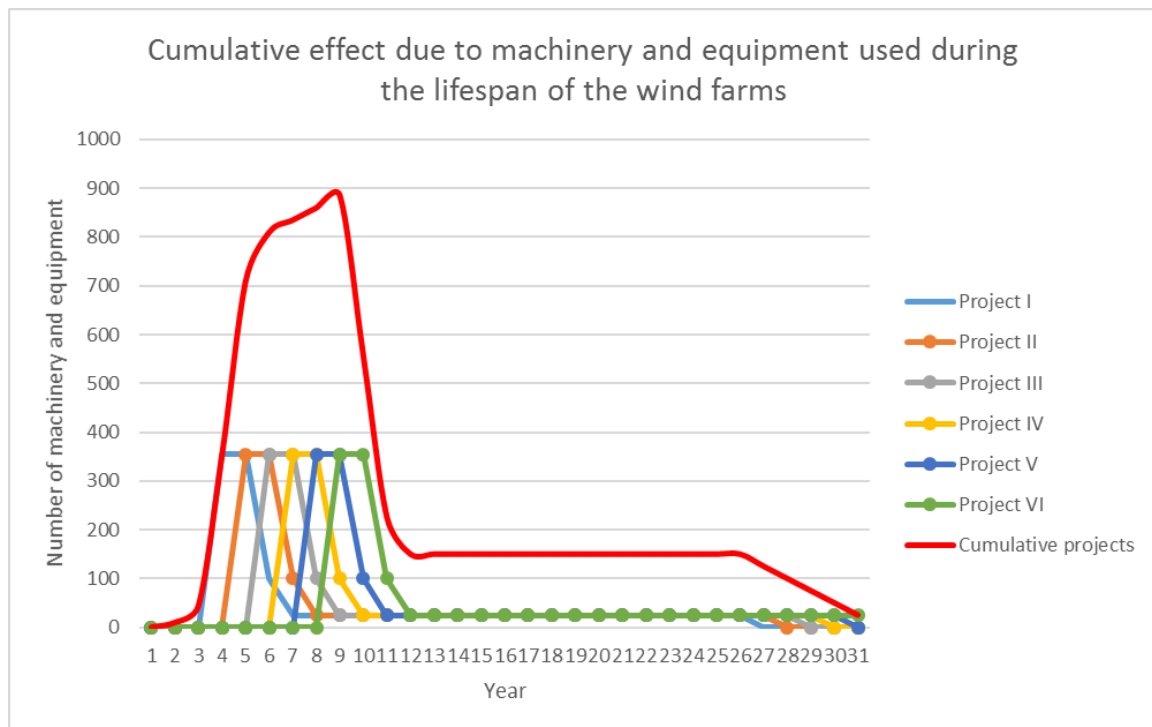

Figure 5.8: Cumulative effect of wind farm development (in the 3rd (i.e. the most realistic) scenario)

It should be noted that during the construction phase water supply trucks will use the existing infrastructure in order to bring water to the sites. All other machineries and equipment used during the construction will be delivered at each individual wind farm site and will be used for construction of individual project's roads, crane pads, foundation etc.

During WTG erection and installation phase all mentioned machineries will use the existing infrastructure for bringing WTG equipment on sites.

Analyzing the most realistic scenario (3rd scenario) it could be seen that the impact of cumulative effects of construction, installation and operation of the project is approx. 2.5 times higher than construction, installation and operation of project sets of 4 to 5 individual projects. As the existing road infrastructure consist of four lane road Suez-Hurghada and two roads crossing the project area, one in the south (near observation site 11 and 12) and one in the middle (between observation sites 8 and 9), the existing infrastructure is assumed to be satisfactory for transporting heavy equipment, according to the above mentioned scenario (3rd scenario). Nevertheless, heavy equipment transport might have a negative impact on the existing road infrastructure, i.e. damaging part of the roads, traffic overloading (traffic jams), etc.

Future road infrastructure, i.e. access roads from the existing asphalt roads to a single wind farm site or to several sites shall be planned and considered in the way to have the capability to transport all machineries and equipment taking into account the synchronous construction and overlapping of projects as shown in 3rd scenario.

Establishing a macro management plan for the construction, installation and operation of the future wind farms (including the usage and availability of the roads, grid infrastructure, water and waste management) is recommended. This macro management plan shall be supervised by authorities e.g. from NREA and/or EETC. A traffic management plan should be prepared in cooperation with traffic department inside the Ministry of Interior Affairs. If needed, careful turns for heavy trucks and loaders due to the high-speed vehicles passing by the highway shall be provided. The effects of additional traffic load on the regional roads shall be further reduced by shifting of heavy haulage transports to low traffic hours (such as late evening or nighttime hours).

5.5.3 Rapid Cumulative Impact Assessment

According to the IFC Handbook (2015, p. 19) “for practical reasons, the identification and management of cumulative impacts are limited to those effects generally recognized as important on the basis of scientific concerns and/or concerns of affected communities”. Hence, the CIA should be risk based and should focus on environmental and social subjects that might be affected by successive, incremental and/or combined effects of different projects. Speculative assumptions relating to potential or possible projects must not be considered in detail. Consequently, important issues to be incorporated in the CIA for wind farm developments in the project area are:

- impacts on migrating birds (Chapter 5.5.3.1);
- landscape and visual impacts (Chapter 5.5.3.2); and
- socio-economic impacts (Chapter 5.5.3.3).

The following studies give valuable baseline information and useful assessments of impacts to be expected by wind farms in the region:

- Strategic ESIA for the 300 km² area (JV LI & ecoda 2013)
- Strategic ESIA for the 200 km² area (JV LI & ecoda 2011)
- Project-specific ESIA study for 200 MW MASDAR wind farm (Bergen et al. 2016)
- Post-construction monitoring for Gabel Al-Zayt Wind Farm Project (Al-Hasani 2014; Al-Hasani & Al-Mongy 2016)
- Post-construction monitoring including shutdown on-demand operations for 200 MW KfW wind farm (Strix 2016)
- Project-specific ESIA study for Alfa Wind Project (EcoConServ 2016)

5.5.3.1 Migrating Birds

5.5.3.1.1 Collision Risk

Autumn Migration

As given in Chapter 4.3.4.3.4, the project area is not of particular importance for large soaring birds during autumn migration. Over vast periods of the autumn season migratory activity of relevant species was low. Remarkable migratory activity was restricted to single days and mainly referred to larger flocks of three species (European Honey Buzzard, White Stork and Great and White Pelican made up about 98 % of all recorded birds). None of these species is considered as to be threatened or near threatened.

As a consequence, collision risk at multiple wind farms in the project area is not assumed to pose a major threat for large soaring birds in autumn. Single collisions at wind farms within the project area might occur even during autumn migration, but the expected collision rate will not cause significant effects on the populations. Thus, collisions at wind turbines within the project area during autumn are not believed to have a significant impact on migrating birds. This assessment needs to be verified by a thorough post-construction monitoring at operating wind farms (see Chapter 6.4.2.2). Furthermore, general mitigation measures shall be applied to reduce collision risk as much as possible (Chapter 6.4.2.2).

Spring Migration

As given in Chapter 5.3.4.1, collisions at a single wind farm within the project area during spring migration might lead to a significant adverse impact on population of single target species. The same conclusion has been drawn by recent impact assessments for other wind farms at the Red Sea coast (e.g. Bergen et al. 2016, JV LI & ecoda 2013, JV LI & ecoda 2011, DECON & Fichtner 2007). All the more significant effects on populations must be expected when operating multiple wind farms within the project area. Assuming that birds might face more frequently critical situations at one wind farm after having avoided or escaped the other wind farm, operation of multiple wind farms might not only lead to a simple additive collision risk, but might also increase collision risk in a disproportional way. Hence, substantial efforts are required to reduce the risk of collisions of large soaring birds in spring at multiple wind farms (see Chapter 6.4.2.2).

Side note on collision risk for migrating birds at the 220 kV overhead powerline

It is well known that overhead powerlines can have a significant impact on breeding, roosting and migrating birds. Three main risks to birds have been identified: risk of electrocution, loss of habitat or decrease of habitat quality and, finally, collision risk (e.g. BirdLife International 2015a). For migrating birds collision risk is doubtlessly the most dangerous effect. In flight, birds can collide into the cables of powerlines, because the cables are difficult to perceive as obstacles. In most cases the impact of collision leads to immediate death or to fatal injuries and mutilations. Casualties from migratory soaring bird species have already been found at a powerline at the Red Sea coast (EcoConServ 2015). The risk may even be higher in situations where powerlines and wind turbines act together, e.g. migrating birds might come into a critical situation at powerlines while escaping the rotor blades of a wind turbine (or vice versa). For that reason it is strictly advisable to mitigate the risk of collision at the powerline which borders the project area in the east (see Map 1.3) by increasing the perceptibility of the cables (Chapter 6.4.2.2). Therefore well-visible markers shall be attached on cables posing a high collision risk, in particular the neutral cable of high-voltage powerlines.

5.5.3.1.2 Barrier effect

Autumn Migration

Multiple wind farms within the project area might cause cumulative barrier effects on large soaring birds (e.g. Cabrera-Cruz & Villegas-Patracca 2016). However, as given in Chapter 4.3.4.3.4, the project area is not of particular importance for large soaring birds during autumn migration. Single birds or flock of birds might take a detour to avoid wind farms or might gain height to cross areas at altitudes well above turbine height. As only a small number of birds will be affected, cumulative barrier effects are unlikely to cause significant effects on populations of target species.

In addition, birds migrating in southwestern direction, i.e. one of the preferred flight directions in autumn (see for instance Map 4.3), might not consider multiple wind farms as one obstacle, because FiT-plots are located at distances of more than 1 km to each other. Because of the remaining space between individual FiT-plots, birds will find sufficient space to safely migrate between plots (see Map 5.2; if not simply migrating above wind farms).

To conclude, barrier effects at multiple wind farms in the project area are not assessed to pose a significant impact on large soaring birds in autumn. This assessment needs to be verified by a thorough post-construction monitoring at operating wind farms (see Chapter 6.4.2.2).

Spring Migration

As shown in Chapter 4.3.4.4.6, the project area is of high importance for at least ten target species during spring migration. Hence, if birds consider wind farms as one obstacle and actively avoid such obstacle (as it is known for raptors; see for instance Cabrera-Cruz & Villegas-Patracca 2016), a nameable portion of the flyway population of these species might be affected by multiple wind farms causing cumulative barrier effects. This is particularly valid for operating wind farms. Nevertheless, large wind farms might even lead to barrier effects when wind turbines are shut down.

Barrier effects might provoke very complex and critical situations that can hardly be predicted:

1. Birds approaching the project area from the south might change their flight paths to the northeast in order to avoid wind farms in FiT-plots 1-4, 2-4 and 3-4. In doing so, these birds subsequently migrate near the coastline and follow the Red Sea coast further north-northwest (see Map 5.3). Assuming that these birds avoid entering large wind farms in the project area, they likely do not shift their migration route further inland (to the west), but stay close to the coastline for about 40 km. On this route birds might face the risk of being drifted off to the sea by strong winds from north-western directions. As no thermal uplifts exist above open bodies of water, those birds cannot gain height by soaring flight, but have to struggle against the wind in order to reach the desert plains by active flight. Hence, to be drifted off to the sea poses a potential risk for large soaring birds in term of additional energy expenditure and - as a worst case - in terms of mortality.
2. Birds approaching the project area from the south might change their flight paths to the northwest in order to avoid wind farms in FiT-plots 1-4, 2-4 and 3-4. In doing so, these birds subsequently pass the project area at its western side (see Map 5.3). Further north the space between wind farms in the project area and in the 300 km² area becomes smaller and, finally, the two areas merge. Thus birds will face a broad front of wind turbines, e.g. at FiT-plot 1-2 and adjacent wind farms or at FiT-plots 1-1 and 2-1 (see Map 5.3). After having approached these plots birds might be trapped by wind farms in the west, the north and the east.

The most efficient way to escape this situation is to gain height and to fly over wind farms located in the northern plots (e.g. 1-1, 4-1 and 8-1) well above turbine height. However, this option might become difficult if no thermal uplift exists whenever and wherever needed. This option might

even be not applicable in conditions that do not favour thermal uplifts (e.g. due to climatic conditions or possibly due to operating wind turbines (it is unknown whether turbulences caused by operating turbines might hinder formation of thermal uplifts)). If flying over wind farms at higher altitudes is an option, it still remains questionable whether birds will be able to safely cover the whole distance of about 10 km to escape the project area at its northern edge in one gliding flight bout (i.e. without another soaring flight to gain altitude above a wind farm area). As birds loose altitude while gliding, they might face the risk of approaching the rotor swept area of wind farms when attempting to cross several wind farms at once (leading to an increased collision risk if turbines are operating). In addition, according to the prevailing wind conditions at the Red Sea coast birds are usually drifted to the southeast during soaring flights, which usually lasts several minutes but can take half an hour or even more. Thus, the distance birds have to bridge in order to reach the northern edge of the project area is increased by this effect making the situation even more difficult for large soaring birds. Furthermore, this effect might increase the risk of collision at wind turbines in FiT-plots further south (e.g. 5-5 or 8-5), when birds are drifted to a row of operating turbines.

As the gaps between the different FiT-plots in the northern part of the project area are rather small (less than 300 m) and probably not sufficient to reduce the potential for barrier effects, birds that do not (or are not able to) gain altitude have to fly back - probably in southwestern directions - searching for opportunities to escape the wind farms areas (e.g. between FiT-plots in the 300 km² area). The additional flight path caused by this detour might add up to about 50 km. Whether this has a relevant impact on a bird's fitness remains unclear.



One can even expect that - depending on other factors (e.g. climatic conditions, time of day) - birds trapped in a complex situation might stop migration and go down for a stop-over or for spending the night in the desert. Those birds might face an additional risk of collision at wind farms while landing and then while starting again.

3. Birds showing no clear avoidance behaviour at a larger scale might approach the wind farm within FiT-plot 2-4 and might get trapped by other wind farms in the west (FiT-plot 1-4) and in the east (FiT-plot 3-4; see Map 5.3) leading to the above-mentioned effects. Nevertheless, as options to bypass the wind farms exist, the magnitude of such effects is definitely lower than further north (as described above). But, again, avoiding and / or escaping one large wind farm might increase the risk to collide at wind turbines within another wind farm.

It must be pointed out that birds might be more flexible as they can use the space below and above the rotor swept area and between single turbines. Furthermore in most cases the majority of birds recorded in spring 2016 and 2017 migrated well above turbine height (Chapter 4.3.4.4). In addition, barrier effects are likely species-specific and, thus, single species might show no avoidance behaviour at all. More knowledge is necessary to reliably assess the magnitude of barrier effects and the need for mitigation. Hence, these issues should be addressed in the post construction-monitoring of each individual wind farm. However, bearing in mind the uncertainty of predictions application of the precautionary principle and implementation of appropriate mitigation measures is - from a technical point of view - strictly advisable.

Map 5.2
 Schematic illustration of likely flight paths of target species in autumn under the precondition of barrier effects caused by large wind farms

FiT-plots

-  FiT-plot for 50 MW wind farm in the project area
-  FiT-plot for 50 MW wind farm in the 300 sqkm area

Schematic illustration

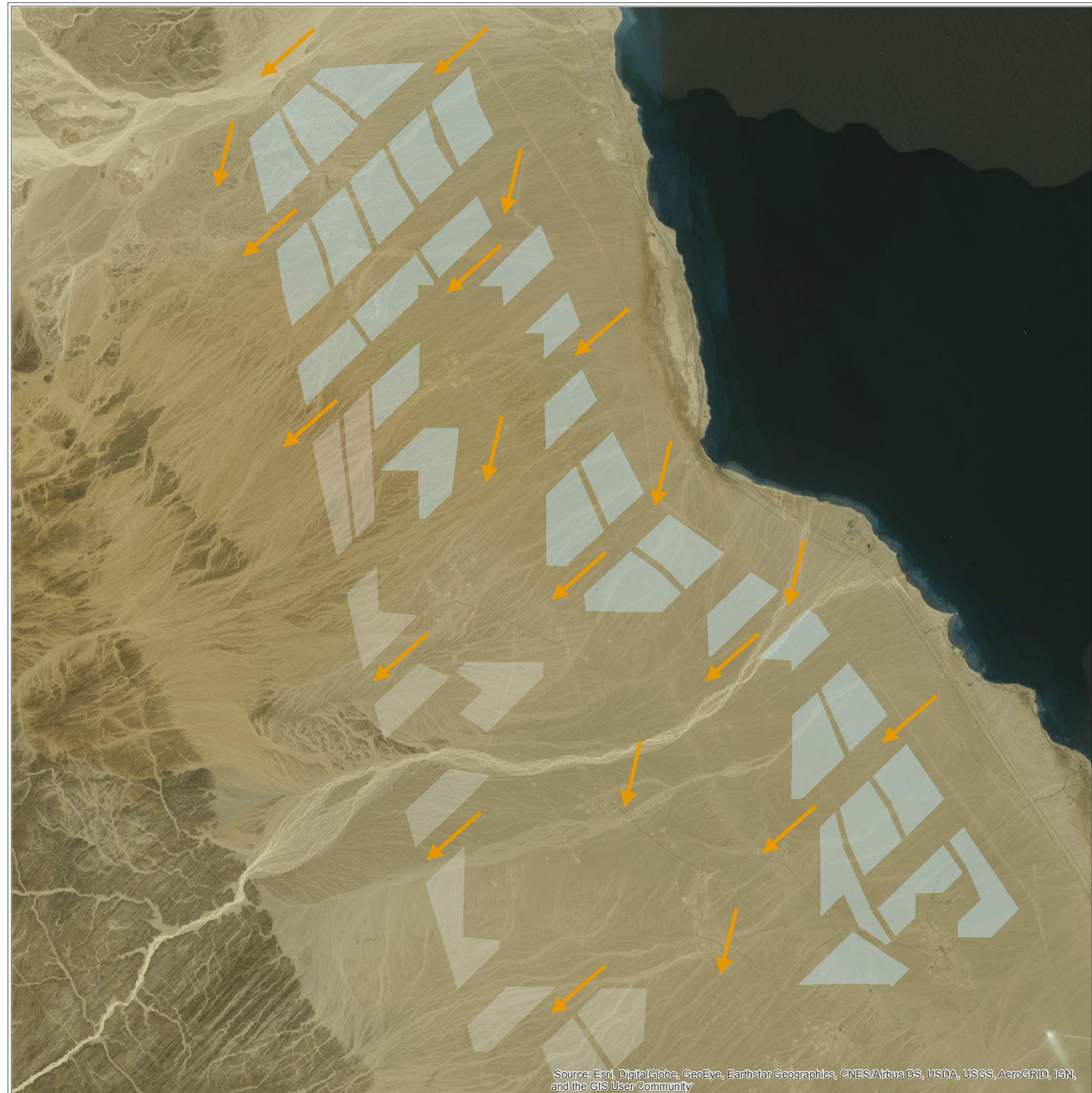
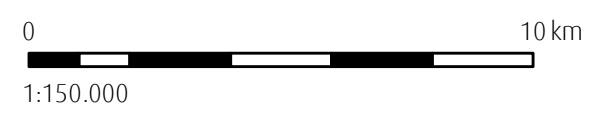

-  Likely flight path for target species in autumn (without risk potential in this scenario)

● editor: Lars Gaedicke, July 31st 2017





Map 5.3
Schematic illustration of likely flight paths of a nameable portion of target species in spring under the precondition of barrier effects caused by large wind farms

FiT-plots

-  FiT-plot for 50 MW wind farm in the project area
-  FiT-plot for 50 MW wind farm in the 300 sqkm area

Schematic illustration

-  Likely flight path for target species in spring (without risk potential in this scenario)
-  Likely flight path for target species in spring (with risk in this scenario; see text)

● editor: Lars Gaedicke, July 31st 2017

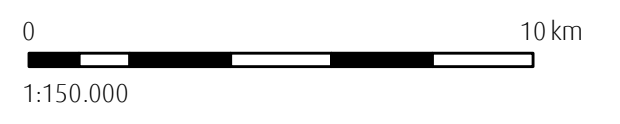

5.5.3.1.3 Synopsis – Final Assessment of the Expected Cumulative Impacts on Migrating Soaring Birds
 Due to the lack of knowledge the magnitude of collision risk at multiple wind farms can hardly be assessed. Applying the precautionary principle, collision risk during autumn migration is regarded as high leading to a moderate impact (Figure 5.9), as “receptor sensitivity” is assessed to be low (see Chapter 5.3.4.1). The magnitude of a barrier effect of multiple wind farms is regarded as medium to high leading to a minor to medium impact on large soaring birds in autumn (Figure 5.9).

Hence, no particular measures are required to mitigate effects of multiple wind farms on large soaring birds during autumn. Nevertheless, a possible barrier effect still needs to be thoroughly investigated during post construction-monitoring at operating wind farms.

		Autumn migration		
		Sensitivity		
Magnitude of effect	Multiple wind farms	Low	Medium	High
	Low			
	High	Barrier effect Collision risk		

Figure 5.9: Impact matrix to assess cumulative effects of multiple wind farms in the project area on migrating birds in autumn (negligible, minor, moderate, major)

Collision risk at multiple wind farms in the project area during spring migration must be regarded as high leading to a major (significant) impact on large soaring birds (Figure 5.10). The magnitude of a barrier effect of multiple wind farms is regarded as medium. Consequently, barrier effects might lead to major (significant) impact on large soaring birds in spring, too (see Figure 5.10). Thus, appropriate mitigation measures are required for both, collision risk and barrier effect (see Chapter 6.4.2.2).

		Spring migration		
		Sensitivity		
Magnitude of effect	Multiple wind farms	Low	Medium	High
	Low			
	High			Barrier effect Collision risk

Figure 5.10: Impact matrix to assess cumulative effects of multiple wind farms in the project area on migrating birds in spring (negligible, minor, moderate, major)

5.5.3.2 Landscape and Visual Impact

As given in Chapter 5.2.6, the wind farms within the project area will cause an adverse impact on the landscape character. The same conclusion has been drawn within the impact assessment for other wind farms (Bergen et al. 2016, JV LI & ecoda 2013, JV LI & ecoda 2011).

It is obvious that the visual impact will increase with the number of installed turbines in an area and that single wind farms may appear as one huge wind farm depending on the location of an observer. Here, it is important to state that no people live in an area that is assumed to be significantly impacted.

Few facilities of the petrol company are located within an area of high visual impact, mainly at the southern border of the project area. From a location south of the area few wind farms will visually merge to a single wind farm (most probably those projects in plots 1-4 to 6-4; see Map 5.1). Nevertheless, this has to be assessed as a typical cumulative impact. As the distance of Ras Ghareb-El Shaikh Fadel road, which is located about 5 km south of the project area, is rather large, the cumulative impact of single wind farms (most probably project in plots 1-4 to 3-4) is assessed to be low.

The same cumulative impact is expected to appear at the northern site of the project area, where turbines in plots 3-1 and 8-1 to 10-1 will probably lead to combined effects on landscape character. However, no relevant receptor exists north of the project area.

Again, no relevant receptor exists west of the project area, beside two petrol facilities that are located at distances of more than 2 km.

The largest cumulative impact will appear at the eastern site of the project area when travelling on Suez-Hurghada road in northern or southern direction. Several single wind farms will be perceivable from the road at the same time. An observer will probably experience those projects as one enormous wind farm with an extent of about 40 km. However, due to the distance of more than 2 km to the proposed wind farms the Suez-Hurghada road is located in an area of moderate impact.

To conclude, cumulative impacts on landscape character will definitely appear, mainly on people using the Suez-Hurghada road. Here, it has to be acknowledged that the impact on a receptor is rather subjective highly depending on the particular opinion of the affected receptor on wind power and renewable energies in general.

5.5.3.3 Socio-Economic Impacts

Although the individual contribution of a single 50 MW wind farm may represent only a minor or moderate socio-economic effect, the cumulative effect of all wind farm developments in the 284 km² area is likely to represent a substantial positive change in respect to local employment opportunities, local economy and infrastructure in the community of Ras Ghareb.

The construction of the wind farms is expected to create both direct and indirect employment opportunities. In addition, materials needed for civil works and infrastructure improvements will be procured in the local municipality creating opportunities for local contractors. Construction of wind farms will require access roads which will have a beneficial impact on infrastructure in the area. At the operational phase, presence of several wind farms may even support the growth of local industry for service and maintenance.

Municipal budgets are likely to be increased as a result of agreements between the wind farm operators and the local municipality (e.g. profit sharing agreements or similar) and social investment programs. Operation of wind farms could also have an effect on increased tourism opportunities, especially in the community.

6. Mitigation of Environmental Impacts

6.1 Mitigation Strategy

After having thoroughly assessed the impacts the so-called mitigation hierarchy shall be applied as the general mitigation strategy. The first step in this process comprises measures to avoid environmental or social impacts of a plan/project, by changes in the project design or in project activities. If it is not possible to avoid an impact additional measures should be implemented to minimize the identified effect, e.g. by shutting down turbines during a certain period of time to protect migrating birds. The remaining impacts have to be rectified, e.g. by restoration of habitats to their original state or by relocation of affected species or habitats. The last option in the mitigation hierarchy is to compensate for or to offset any residual, unavoidable loss or damage. Such biodiversity offsets generally take place in a different area and aim for securing a “no net loss” outcome.

The mitigation strategy shall be accompanied by a thorough risk management covering post-construction monitoring and adaptive management.

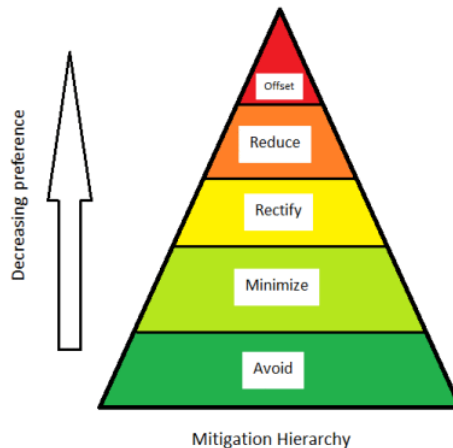

Figure 6.1: Schematic presentation of the so-called mitigation hierarchy to be applied as a general strategy

Based on the findings of the impact assessment the following chapters provide an overview of the management and mitigation measures required during construction, operation, maintenance and decommission phase of wind farm developments in the project area. As activities for decommission are comparable to those for construction of wind farms the required management and mitigation will be considered together (see Chapter 6.3). The largest need for management and mitigation exists for migrating birds. The reduction of collision risk for large soaring birds in spring by appropriate and sound measures will be essential for an agreeable, harmless and sustainable operation of wind farm developments in the project area (see Chapter 6.4.2.2).

6.2 General Management and Mitigation - Best Practice

The following management and mitigation measures can be regarded as a best practice standard that shall be applied under any condition and during any project phase (construction, operation, maintenance and decommission):

- All activities must be restricted to the boundaries of the construction areas, storage positions and access roads/tracks. Any use of the surroundings must be strictly avoided.
- Supplying or changing oil, lubricant or hydrocarbon to vehicles shall be done in gas stations and not on site. Strict control must be applied by a site supervisor. Contingency measures and plans for spill removal must always be ready on site.
- Waste has to be removed immediately and has to be safely stored at the site so that drifting is avoided.
- Awareness programmes to personnel shall be carried out. Behaviour and attitude of involved personnel during field activities shall be controlled by a site supervisor.
- Potential occupational health and safety hazards during the construction phase shall be controlled by appropriate measures.
- The contractor shall provide effective protection for land and vegetation resources at all times and shall be held responsible for any subsequent damage.
- The contractor shall be forced to good workmanship and housekeeping during construction by contractual stipulations and by assignment of supervising engineers in order to assure adequate disposal of solid waste and waste water, to avoid or to collect spillages of used oils, greases, etc.
- The contractor shall be forced not to leave the construction site unless the area was put into tidy conditions, excavations are backfilled, heaps of excavation material is levelled and waste is adequately disposed of.

Potential occupational health and safety hazards during the construction phase shall be controlled by

- Assignment of a health and safety engineer by the contractor for the different work lots with full power for giving health and safety instructions.
- Strict implementation of wind power manufacturers health and safety instructions concerning the construction, operation, maintenance and decommission of the wind turbines such as:
 - o Establishment of a health and safety plan for the construction site;
 - o Provision of safety tools and equipment as to accepted standards by the contractor;
 - o Employment of personnel only on the turbines, which has passed a wind power safety training course; and
 - o Strict avoidance of works during poor weather conditions (wind speeds beyond limits and lightning risk).
- Strict supervision of health and safety measures of the local civil works companies, which may be employed via the contractor, especially with regard to wearing safety clothes, to equipment safety and a safe working environment.
- Strict supervision of keeping health and safety standards for working at electricity generation, transmission and distribution devices.

6.3 Management and Mitigation during Construction and Decommission

6.3.1 Physical Environment

Except from applying best practice procedures during construction and decommission no further management and mitigation is required with regards to climate, because no adverse impact is expected by the construction / decommission of wind farms and associated infrastructure in the project area.

The standard dust control measures that are commonly used on construction sites shall be implemented to minimize the impact on air quality:

- Water-spraying of roads, surfaces prior to being worked, and material stockpiles to minimize dust raising, as required (this is probably not a reasonable measure in a desert area where water is of extremely high value);
- Sheeting vehicles carrying dusty materials to prevent materials being blown from the vehicles whilst travelling;
- Enforcing speed limits for vehicles on unmade surfaces to minimize dust entrainment and dispersion; and
- Employing suitable measures to ensure that vehicles leaving the site do not entrain dust onto public roads.

Measures shall be implemented to reduce the risk of contamination of water resources and soil posed by potential sources of pollutants (such as fuels, oils, chemicals and associated liquid waste materials). These materials shall be stored in dedicated, segregated storage areas, with spillage protection and appropriate environmental security measures to prevent accidental release to ground during storage. In addition, appropriate working procedures shall be adopted to ensure an appropriate handling with these materials. Sanitary waste water shall be collected at site and shall be removed from site for treatment at an appropriate treatment facility.

As construction and decommission activities will be temporary and transient they will not lead to a significant adverse impact on landscape. Hence, except from applying best practice procedures during construction and decommission no management and mitigation is required.

In the event that the aforementioned management and measures will be implemented no significant adverse impacts on the physical environment are expected by construction/decommission of wind farms and associated infrastructure in the project area.

6.3.2 Biological Environment

No significant impacts caused by construction/decommission activities calling for particular mitigation measures have been identified in the process of the assessment. Nevertheless applying the general measures to avoid or - at least - minimize any impact on flora and fauna during construction and decommission is crucial. This covers:

- Restrict all activities to the boundaries of the construction areas, storage positions and access roads/tracks. Any use of the surroundings must be strictly avoided.
- Avoid establishing spots (waste dump, open water bodies, gardens or houses with vegetation) that might attract animals.
- Consider the regulations defined in Article 28 of the Egyptian Law no. 4/1994 for the Protection of the Environment amended by Law 9/2009, i.e. mainly a ban of
 - o hunting, killing, catching birds and wild animals or marine living organisms;
 - o cutting or damaging protected plant species;

- collecting, possessing, transporting, or offering to sell kinds of fauna and flora fossils or changing their features; and
- trading in all endangered living organisms of fauna and flora species.
- Main wadis, which hold sparse vegetation, form specific elements in the desert and can temporarily be used as foraging and hunting sites for local birds. Therefore, construction works in the wadis shall be minimized.

To mitigate impacts on migrating, roosting and local birds caused by large wind farms in the project area the following measures should already be considered in the planning and construction phase:

- Avoid turbines with lattice towers. Lattice towers offer suitable perching sites and, thus, might attract migrating, roosting and local birds which in turn might increase the risk of collision.
- Paint turbine blades to increase blade visibility and, thus, to decrease collision risk for migrating roosting and local birds. This can be achieved by using blades with black and white aviation markings (see also Hodos et al. 2003).
- Restrict turbine height to a reasonable maximum total tip height, as collision risk for migrating birds is believed to increase with turbine height. In recent ESIA studies a maximum total tip height of 120 m was recommended. However, this should not be regarded as a strict limitation. According to the technical characteristics of modern turbines exceeding a height of 120 m might be acceptable to a certain degree.
- Avoid lighting of wind turbines, as birds might be attracted to wind farm areas by lights leading to an increased collision risk. If lighting of turbines is absolutely required (e.g. to meet aviation requirements of the civil and military aviation authority), the minimum number of intermittent flashing white lights of lowest effective intensity shall be used (Drewitt & Langston 2006).
- Build the grid within a wind farm area and the grid between different wind farm areas by underground MT cables. If the use of overhead lines cannot be avoided (e.g. 220 kV OHL), such overhead lines should be designed according to available guidelines (e.g. BirdLife International 2015a).

Furthermore, development of wind turbines in the eastern part of FiT-plot 3-4, which overlaps with the Important Bird Area Gebel El Zeit, needs to be discussed amongst relevant stakeholders.

Except from considering and applying the mentioned measures no further management and mitigation is required with regards to flora and fauna and habitats, because no residual significant adverse impacts are expected by construction/decommission of wind farms and associated infrastructure in the project area.

6.3.3 Social and Economic Environment

Relevant occupational health and safety standards shall be considered and compliance with the standards shall be controlled during the construction/decommission of wind farms and associated infrastructure in the project area (e.g. IFC 2007).

The littering of waste and the spillage of hazards shall be avoided by proper workmanship and strong supervision.

In the event that the aforementioned management and measures will be implemented no significant adverse impacts on the social and economic environment are expected by the construction/decommission of wind farms and associated infrastructure in the project area.

6.4 Management and Mitigation during Operation and Maintenance

6.4.1 Physical Environment

As the operation of wind farms will have a positive, but no adverse effect on climate no management and mitigation is required during the operation and maintenance phase.

As wind farms will not lead to significant adverse impacts on air quality during operation and maintenance phase further management and mitigation is not required.

Sanitary waste water shall be collected at site and shall be removed from site for treatment at an appropriate treatment facility. Waste water shall not be discharged to either groundwater or surface water. Measures shall be implemented to reduce the risk of contamination of water resources and soil posed by potential sources of pollutants (such as fuels, oils, chemicals and associated liquid waste materials) during the operation and maintenance phase.

No specific management and mitigation measures are available to reduce the impact of wind farms and associated infrastructure on landscape.

In the event that the aforementioned management and mitigation measures will be implemented no significant adverse impacts on the physical environment are expected by the operation/maintenance of wind farms and associated infrastructure in the project area.

6.4.2 Biological Environment

6.4.2.1 Flora, Fauna (except birds) and Habitats

In order to protect the flora, fauna and habitats of the project area - in particularly species protected by Egyptian legislation (e.g. Rüppell's Sand Fox, Egyptian Jackal, Cape Hare and Egyptian Dabb Lizard) - the regulations defined in Article 28 of the Egyptian Law no. 4/1994 amended by Law 9/2009 have to be followed and best practice procedures and general mitigation measures during operation and maintenance have to be applied.

Beyond that no additional management and mitigation is required with regards to flora and fauna and habitats, because no residual significant adverse impacts are expected by operation/maintenance of wind farms and associated infrastructure in the project area.

6.4.2.2 Birds - Avifauna

6.4.2.2.1 General Mitigation Measures for Migrating, Roosting and Local Birds

Langston & Pullan (2004) pointed out that, as a precautionary measure, it should be avoided to locate a wind power plant at international or national sites for nature conservation or other areas with large concentrations of birds, such as points of migration crossings. According to Percival (2005) it is important to avoid developing wind farms at sites i) with high-density raptor populations where collisions could be significant, and ii) with high densities of other species vulnerable to a low level of additional mortality where their susceptibility to wind turbine collision may be high.

The project area somehow meets the above mention criteria, but only temporarily during short periods in spring. This is an exceptional case that requires a careful development of wind farms in the area applying the precautionary principle and a thorough risk management. In addition, as mentioned above, development of wind turbines in the eastern part of FIT-plot 3-4, which overlaps with the Important Bird Area Gebel El Zeit, needs to be discussed amongst relevant stakeholders ensuring the preservation of the ecological function of the IBA Gebel El Zeit as a migration corridor for large soaring birds.

During the operation and maintenance phase of wind farms in the project area the following general measures should be implemented in any case (these measures have already been detailed above, as it is important to consider them thoroughly in the planning and operation phase):

- Avoid turbines with lattice towers;
- Paint turbine blades to increase blade visibility;
- Restrict turbine height to a reasonable maximum total tip height (e.g. about 120 m);
- Avoid lighting of wind turbines; and
- Avoid attracting migrating birds (e.g. by waste dump, open water bodies).

Side note on collision risk for migrating birds at the 220 kV overhead powerline

As given in Chapter 5.5.3.1.1, it is strictly advisable to mitigate the risk of collision at the already existing overhead powerline which borders the project area in the east (see Map 1.3) by increasing the perceptibility of the cables. Therefor well-visible markers can be attached on cables posing a high collision risk, in particular the neutral cable of high-voltage powerlines. By using appropriate markings (e.g. bird flight diverters; see BirdLife International 2015a) residual significant adverse effects on migrating birds can be avoided.

6.4.2.2.2 Autumn Migration

Neither a single FiT-plot nor the whole project area is of particular importance for migrating birds in autumn (Chapter 4.3.4.3.4).

Based on this conclusion collision risk for migrating birds in autumn are assessed as a minor impact when considering an individual wind farm (see Figure 5.3) and as a moderate impact when considering multiple wind farms in the project area (see Figure 5.7). Barrier effects are regarded as a negligible impact on migrating birds in autumn when considering an individual wind farm (see Figure 5.3) and as a minor to medium impact when considering multiple wind farms in the project area (see Figure 5.7). Hence, no further management and mitigation (except from applying best practice procedures and general mitigation measures) is required. No residual significant adverse impact on migrating birds is expected during the autumn season by operation/maintenance of wind farms and associated infrastructure in the project area. Nevertheless, the assumptions made within the impact assessment shall be verified and any significant deviation from predicted impacts (if any) shall be identified by a comprehensive post-construction monitoring at operating wind farms (see below).

6.4.2.2.3 Spring Migration

Collision Risk

As given in Chapter 5.3.4.1.3, collision rates leading to additional mortality potentially causing significant population effects for some species cannot be excluded when operating a large wind farm within the project area. Collision risk at a single wind farm in the project area during spring migration is regarded as major (significant) impact (Figure 5.4) requiring appropriate mitigation measures.

Collision risk for migrating birds at wind turbines in the project area is mainly restricted to

- turbines under operation (note that this might be different for barrier effects);
- certain periods of the year (spring); and
- certain periods of the day (migration of most large soaring birds starts when appropriate thermal uplifts are available).

These considerations hint at appropriate countermeasures for reducing collision risk at an individual wind farm to an acceptable level. If turbines do not operate during periods of high migratory activity and / or periods when larger flocks occur, collision risk for migrating birds can be minimized. Thus, operation of a large wind farm in the project area seems to be acceptable if an effective shutdown program will be developed and established and if technical avoidance and further mitigation measures to the best standard practice (see above) will be maintained. With regard to the development of such a shutdown program, two alternate approaches are possible:

- Fixed shutdown (FS) program

A FS-program presents a worst case-scenario assuming a high collision risk for migrating birds during the overall migration period and during the entire daytime. The FS-program might be applied in the case that no alternate mitigation measures are effective. Under consideration of the precautionary principle the FS-program follows a conservative approach in which collision risk at operating turbines will be minimized, while in return the loss of energy yield of a wind farm will be highest.

If applying a FS-program all turbines of a wind farm shall be stopped during the critical migration period in spring (i.e. March 1st to May 18th) during daytime (i.e. 1.5 hour after sunrise to 1.5 hour before sunset).

- Shutdown on-demand (SOD) program

A SOD-program is regarded as a useful and effective mitigation measure for reducing collision risk for migratory soaring birds at wind turbines. It is of particular value in areas where the impact on migrating birds cannot be reliably predicted, where the impact could vary greatly depending on specific weather and migration patterns and where high concentrations of birds during passage or vulnerable species occur (Birdlife International 2015b).

When applying a SOD-program selected turbines are stopped in times of high collision risks, i.e. during periods of high migratory activity or when a large flock approach a wind farm. Special consideration has to be given to the criteria used in triggering a shutdown. Criteria should aim at minimizing the risks to birds while at the same time reducing losses of energy yield. In the absence of detailed information as to the factors influencing high-risk situations these criteria must remain dynamic and flexible in order to be able to react to new information and knowledge (Birdlife International 2015b).

A SOD-program has already been implemented at KfW and JICA wind farms (Strix 2016, ecoda in prep.) located about 40 km south(east) of the project area. During execution of the SOD-program at the two wind farms four criteria for triggering the shutdown of turbines have been applied:

1. Threatened species

Turbines shall be shut down whenever a bird or birds of a threatened species (according to the IUVN Red List) are detected migrating through the wind farm area or heading towards it at risky flight altitudes (i.e. within the rotor-swept area).

2. Flocks with 10 or more large soaring birds (target species)

Turbines shall be shut down whenever flocks with 10 or more large soaring birds are detected migrating through the wind farm area or heading towards it at risky flight altitudes.

3. Imminent high risk of collision

A single turbine or turbines shall be shut down whenever there is an imminent high risk of collision of a large soaring bird (e.g. a bird approaching a turbine at a close distance).

4. Sand storms

Turbines shall be shut down during sand storms whenever criteria 1 and 2 have been verified in the two hours that preceded the sand storm.

The results gained at KfW and JICA wind farms in spring 2016 and spring 2017 indicate that the SOD-program has been an efficient and successful measure leading to a low number of collision victims (even though a small number of birds collided) and to short periods of shut downs (Al-Hasani & Al-Mongy 2016, Strix 2016, ecoda in prep.). Thus, the criteria for shutting down times used at the two wind farms shall act as a starting point for a large wind farm in the project area. The criteria shall then be fine-tuned through an adaptive management approach resulting from on-going monitoring and benefiting from the experience obtained during the first seasons. An appropriate approach for a SOD-program at a large wind farm in spring and details important for the implementation of such a program are given in Table 6.1.

Table 6.1: Details of an appropriate SOD-program to reduce collision risk for large soaring birds during spring migration

Species to be considered	Target species (large soaring birds); mainly Great White Pelican, White Stork, Black Stork, European Honey Buzzard, Black Kite, Egyptian Vulture, Short-toed Snake Eagle, Levant Sparrowhawk, Steppe Buzzard, Steppe Eagle, Booted Eagle
Seasonal period to be considered	Main migration periods of target species overlap. For instance, White Storks and Steppe Eagles appear already in March, whereas migration of European Honey Buzzard lasts up to mid / end of May. In addition, species-specific migration periods can vary from year to year. Hence, it is appropriate to implement the SOD-program from March 1 st to May 18 th (79 days) covering main migration periods of all target species.
Daily period to be considered	Migratory activity is known to be low in the early morning and the late afternoon (due to the lack of thermal uplifts). Thus, the SOD-program can focus on a daily period from 1.5 hours after sunrise to 1.5 hours before sunset.
Wind turbines / area to be considered	Based on the fact that there were no remarkable spatial differences in migration of target species in the study area in spring, all wind turbines within a wind farm have to be considered in the SOD-program.
Monitoring based on visual observations	<p>The SOD-program shall rely on a proper investigation based on visual observations in which situations with an increased risk of collision for migratory soaring birds have to be assessed and shutdown of turbines have to be initiated, as soon as required. It is likely that a single observation point is sufficient to cover an individual 50 MW wind farm (probably 20 to 25 wind turbines). The locations of the observation site shall be carefully selected to ensure coverage of the whole wind farm and the surrounding area at a distance that allows enough time to carry out shutdown of wind turbines. As birds are coming from southern directions in spring, observation might initially focus on the area south of a wind farm in order to detect migrating birds as early as possible. However, during soaring flight birds might be drifted in south-eastern directions by prevailing winds and might approach a wind farm area even from the north. Hence, it is important to monitor the northern edge of a wind farm, too.</p> <p>Observations should be conducted by a team of two experts (one experienced senior ornithologist and one junior ornithologist). As the daily working period is too long (8 to 10 hours) to be covered by a single team (bearing in mind that the work requires a high attentiveness), two teams will be required to conduct observations 7 days a week. The senior ornithologist will be assigned to communicate (by mobile phone) with the operator in the control station of the wind farm to ensure an immediate shutdown of turbines if required (as already successfully tested at KfW and JICA wind farm). If the mobile network does not allow a communication other means of communication have to be used (eg. radio communication).</p>

Support by using additional radar data	In general, additional real-time data on migrating birds provided by a radar system might be helpful, as this will increase detection rate of migrating birds and the distance of initial detection (birds might be observed earlier, i.e. at larger distances). However, the SOD-program has to focus on the wind farm area and on the critical height bands (i.e. the rotor swept area) which can thoroughly monitored by visual observations only, what has already been proved in the monitoring at KfW wind farm in spring 2016 and at JICA wind farm in spring 2017. When executing the SOD-program there is no need for tracking birds flying well above turbine height or flying at larger (safe) distance to the wind farm under investigation. Moreover, identification of targets tracked by a radar system can only be done by visual observations. Hence, a monitoring based on visual observations will be crucial to run the SOD-program and cannot be replaced by a radar system. To conclude, application of a radar system might strengthen a monitoring based on visual observation, but is not strictly required to successfully execute the SOD-program.
Shutdown criteria for details see text above	<ul style="list-style-type: none"> - Threatened species - Flocks with 10 or more large soaring birds (target species) - Imminent high risk of collision - Sand storms
Rough estimate of yearly cost for a SOD-program during spring	175,000.- € to 200,000.- € covering remuneration, per diems, travel/transport and miscellaneous expenses required for management and execution of a SOD-program and for preparation of a monitoring report
Risk management	The SOD-program shall remain flexible and adopt an approach of adaptive management, particularly with regards to shutdown criteria, options to forecast migratory activity (e.g. in relation to climatic conditions), observation periods and times, location and - maybe - number of observation site etc. The monitoring of collision victims (to be conducted in the post-construction monitoring; see below) is extremely important as an evaluation tool, i.e. to prove whether the proposed approach is working and whether the assumptions that form the basis of the approach are well-founded. The results of the post construction-monitoring will allow reacting immediately and adequately, if adjustments on the SOD-program are necessary.
Additional requirements	Implementation of the SOD-program at an individual wind farm should be harmonized and coordinated with other wind farms in order to make the SOD-program as efficient as possible - both, in terms of mitigation of impacts and in terms of operation of wind farm (see below).

It should be pointed out that the SOD-program offers the opportunity to operate a wind farm even during the migration season in spring when several ten thousands of large soaring birds cross the project area. Thus, the approach helps to maximize the energy yield of an individual wind farm and to increase the benefit for the owner, even though execution of the SOD-program will cause additional cost (as roughly estimated above). Choosing the alternate option, i.e. a fixed shutdown of wind turbines for a period of 79 days in spring, would lead to an immense decrease of the yearly energy yield of a wind farm.

It is obvious that the risk of collision will increase with the number of operating wind farms. Consequently, collision risk at multiple wind farms in the project area is regarded as a major (significant) impact (Figure 5.8) on migratory soaring birds in spring calling for appropriate mitigation measures. Hence, implementation of a SOD-program, as described above, is strictly required for each individual wind farm in every FiT-plot aiming to minimize the number of collision victims at wind

farms in the whole project area. In doing so, even multiple wind farms are unlikely to cause significant population effects on target species. However, a rather low and - after having applied mitigation measures - acceptable risk caused by each individual wind farm might add up to a serious threat for species when considering multiple wind farms. To ensure that such cumulative impacts can be thoroughly considered during the operational phase of multiple wind farms it is crucial to implement an adaptive management process (Figure 6.2) covering the following steps:

- Design and implement appropriate mitigation measures for each individual wind farm.
- Conduct a thorough standardized post-construction monitoring at each individual wind farm.

The post-construction monitoring (for details see below) is crucial to ensure that the shutdown programme and other mitigation measures are thoroughly established and meet their goals and to decide whether additional measures are necessary to minimize or eliminate unacceptable impacts. Moreover, standardized post-construction monitoring at each individual wind farm allows an evaluation on the cumulative effect of multiple wind farms.

- Evaluate the effect of all wind farms on the basis of the results of the post-construction monitoring.

In the context of the evaluation of monitoring results the main question is whether the effect (i.e. the overall number of collision victims) of multiple wind farms remains at an acceptable level.

- Adjust mitigation measures (if necessary) to avoid significant adverse population effects

If the evaluation reveals that significant adverse impacts on populations of single species cannot be excluded mitigation measures have to be adjusted. Adjustments might be, for instance, related to shutdown criteria, shutdown times, critical wind turbines, additional mitigation measures (according to the latest state of the art) or - as a last option - to additional compensation measures aiming for a “no net loss” outcome.

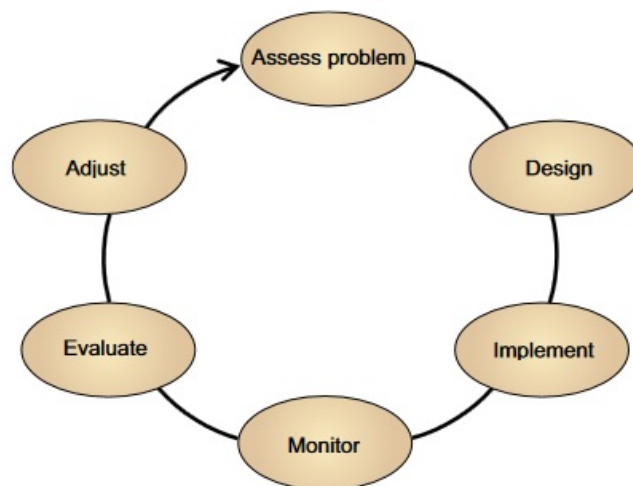

Figure 6.2: Schematic illustration of typical steps undertaken in an adaptive management process

In doing so, operation of wind farms within the project area shall be harmonized and coordinated in order to secure that the additive mortality imposed on bird populations remain at a non-critical level. The experience gained by SOD-programs and the conclusions obtained by post-construction monitoring need to be shared among key stakeholders (e.g. by conducting workshops at regular intervals (e.g. on a yearly basis) to jointly discuss the conclusions and the need for further mitigation measures or for adjustments in the shutdown programme). It is obvious that this cannot be handled by a developer or owner of a single wind farm. Hence, harmonization and coordination of wind farm operation in the project area and guiding the adaptive management process needs to be arranged and accompanied by responsible authorities (most probably by NREA).

To facilitate the complex adaptive management process following a step-wise approach seems to be a reasonable option when developing multiple wind farms in the project area. If, for instance, ten wind farms with a total of 500 MW will be developed in a first phase, the experiences gained with the SOD-program during the first years can be considered in a second and third development phase. As the findings of executed SOD-programs allow calculating the yearly energy loss caused by shutdown periods, the step-wise approach might even minimize the financial risk for developers and investors.

To conclude, the cumulative mortality of migratory soaring birds caused by multiple wind farms in the project area can be minimized to an acceptable level and, thus, multiple wind farms will not cause significant effects on populations of target species, if

- appropriate mitigation measures (SOD-program) will be thoroughly implemented;
- a comprehensive post-construction monitoring will be executed; and
- operation of multiple wind farms in the project area will be coordinated and cumulative effects will be consecutively evaluated (adaptive management).

Barrier Effects

As given in Chapter 5.3.4.1.4, an individual wind farm is unlikely to cause significant barrier effects during spring migration. Barrier effects caused by a single wind farm in the project area are regarded as a moderate impact on migratory soaring birds in spring (Figure 5.4). No further management and mitigation (except from applying best practice procedures and general mitigation measures) is required.

When considering multiple wind farms in the project area barrier effects might provoke very complex and critical situations that can hardly be predicted (Chapter 5.5.3.1.2 and Map 5.3). Hence, a major (significant) impact on migratory soaring birds during spring migration cannot be excluded (see Figure 5.8). Bearing in mind the uncertainty of predictions application of the precautionary principle and implementation of appropriate mitigation measures is, thus, strictly advisable.

Though barrier effects might be stronger at operating wind farms, shutting down turbines (as designed to reduce collision risk) does not seem to be an applicable mitigation measure in this case, because migratory soaring birds might avoid large non-operating wind farms, too. In addition, when executing a SOD-program, as described above, shut down of turbines is triggered by birds approaching a wind farm or certain wind turbines within a wind farm, i.e. on a small scale. By contrast, barrier effects might appear at a larger scale, i.e. at larger distances to a wind farm and, thus, before a shutdown is initiated. Assuming such macro-avoidance behaviour of migrating soaring birds, large wind farms have the potential to negatively affect the ecological function of an area as a migration corridor.

To efficiently reduce potential barrier effects of multiple wind farms in the project area it is recommended to keep sufficient space between wind farms enabling large soaring birds to safely migrate over the coastal desert plains northwest of Ras Ghareb and to continue migration further north. This can only be achieved by a ban of wind farm development in single FiT-plots. From a strict technical point of view the most appropriate approach is to waive installation of wind farms in

- FiT-plot 1-4

This will probably avoid a situation in which birds might get trapped between wind farms in FiT-plots 1-4, 4-4, 2-4 and 3-4. Furthermore, barrier effects that might arise by wind farms in the four mentioned FiT-plots will be reduced. Migrating birds will be able to bypass wind farms in the FiT-plots 4-4, 2-4 and 3-4 more easily by taking a north-western flight direction (see Map 6.1). For that reason, one can assume that the portion of birds that change their flight paths to the northeast (possibly getting in critical situations near the coastline, see Chapter 5.5.3.1.2) will be reduced if no wind farm will be developed in FiT-plot 1-4.

- FiT-plots 1-2 and 2-2, the north-eastern part of FiT-plot 3-2 (partly located in the 300 km² area) and the south-western part of FiT-plot 7-1

In doing so barrier effects that might arise by multiple wind farms in the project area and in the 300 km² area will clearly be reduced. Large soaring birds will be able to safely continue migration heading for north-western directions (see Map 6.1).



- FiT-plots 8-1 and 4-1 and the western part of FiT-plot 1-1



This will avoid a situation in which birds might get trapped by multiple wind farms in the west, the north and the south. Furthermore, barrier effects that might arise by wind farms in FiT-plots 2-1 and 1-1 will be reduced. Large soaring birds will be able to safely continue migration heading for north-western directions (see Map 6.1).

Applying the proposed approach no significant residual impacts on large soaring birds during spring migration (with regards to barrier effects) are expected by multiple wind farms in the remaining FiT-plots. Though there might be other options (i.e. other FiT-plots affected by a ban of developments) the proposed approach seems to be the most efficient one. It will even lead to a reduction of collision risk at wind farms in the remaining FiT-plots and will probably shorten shut down periods at these wind farms.

Again, conducting a post-construction monitoring will be crucial to ensure that the proposed approach meets its goals. Based on the results of the post-construction monitoring one can decide whether additional measures are necessary or additional wind farms can subsequently be developed in the selected FiT-plots (if the monitoring reveals that barrier effects are remarkably lower than assumed in the impact assessment).

Map 6.1
Schematic illustration of likely flight paths of a nameable portion of target species in spring under consideration of the proposed mitigation approach

- FiT-plots**
-  FiT-plot for 50 MW wind farm in the project area
 -  FiT-plot for 50 MW wind farm in the 300 km² area
 -  Areas that should not be selected for wind farm development

- Schematic illustration**
-  Likely flight path for target species in spring (without risk potential in this scenario)
 -  Likely flight path for target species in spring (with risk in this scenario; see text)

● editor: Lars Gaedicke, July 31st 2017

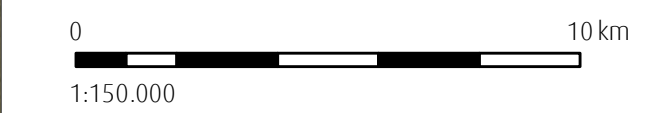

Post-Construction Monitoring / Risk Management

Bearing in mind the uncertainty of predictions and the importance of the Red Sea coast for bird migration execution of a comprehensive post-construction monitoring programme for each individual wind farm is crucial to ensure that the shutdown programme and all other mitigation measures are thoroughly established and meet their goals and to decide whether additional measures are required to minimize or eliminate unacceptable impacts.

The post-construction monitoring programme shall cover at least the first three years of operation (BirdLife International 2016). The main purposes of the post-constructing monitoring programme are:

- Verification of the assumptions made within the impact assessment and determination of significant deviations from predicted impacts;
- Test the effectiveness of mitigation measures (e.g. painting blades, SOD-program, keeping certain FiT-plots free from wind farm development); and
- Identification of possible critical wind turbines and definition of further operational mitigation measures, if required.

The post-construction monitoring shall comprise

- regular and standardized carcass searches at wind turbines (see BERGEN 2007) during spring migration period (from March 1st to May 18th) and during autumn migration period (from August 20th to September 20th); and
- standardized observations of bird behavior (incl. flight paths) in the vicinity of wind turbines during spring migration period (from March 1st to May 18th) to assess the frequency of critical situations and to identify conditions under which critical situations occur (if so).

It has to be pointed out that the post-construction monitoring and SOD-program are two different investigations with different aims and methodical approaches. Hence, one investigation cannot replace the other and both investigations cannot be combined. The post-construction monitoring is extremely important as a tool to evaluation the success of the SOD-program.

Important references for an adequate monitoring program give the experiences already gained at wind farms at the Red Sea coast (Bergen 2007, Al-Hasani 2014, Al-Hasani & Al-Mongy 2016). Further information can be found in National Wind Coordinating Committee (1999), Drewitt & Langston (2006), Band et al. (2007), Follestad et al. 2007, Morrison et al. (2007) or Strickland et al. (2007) and.

6.4.3 Social and Economic Environment

Relevant occupational health and safety standards shall be considered and compliance with the standards shall be controlled during the operation / maintenance of wind farms and associated infrastructure in the project area (e.g. IFC 2007).

The littering of waste and the spillage of hazards shall be avoided by proper workmanship and strong supervision.

In the event that the aforementioned management and measures will be implemented no significant adverse impacts on the social and economic environment are expected by the operation/ maintenance of wind farms and associated infrastructure in the project area.

7. Environmental and Social Management Plan

7.1 Environmental and Social Management

The implementation of mitigation measures require actions during the bidding, planning, construction and post-construction phase for each individual wind farm that will be erected in an accepted plot. These actions can be summarized in the following Environmental and Social Management Plan (ESMP).

Project activity	Environmental Concern	Mitigation Measures	Estimated Cost (EUR)
Bidding and planning phase	Health and safety risks	Make keeping standards as defined in the “Environmental, Health and Safety Guidelines for Wind Energy” (IFC 2007) a minimum obligation in the Tender Documents	To be included in the investment cost
		Make the assignment of a health and safety engineer during the construction process a condition	To be included in investment cost
		Make a health and safety plan for the construction site obligatory	To be included in investment cost
		Make provision of safety tools and equipment as per accepted standards by the contractor a bidding condition	To be included in investment cost
	Important Bird Area Gebel El Zeit	Development of wind turbines in the eastern part of FiT-plot 3-4 needs to be discussed amongst relevant stakeholders	No additional cost
	Birds	Ban wind farm development in FiT-plots 1-4, 1-2, 2-2, 4-1, 8-1 and in parts of FiT-plots 1-1, 3-2 and 7-1	No additional cost
		Avoid turbines with lattice towers	No additional cost
		Limit maximum tip height of wind turbines (about 120 m)	No additional cost
		Paint turbine blades to increase blade visibility	About 10,000 € per MW; to be considered in investment cost
		Avoid establishing spots that might attract birds	No additional cost
		Harmonize and coordinate installation and operation of multiple wind farms in the project area	No additional cost
		Each developer shall be bindingly committed to align with the “adaptive management program” and to strictly follow the recommended measures during all project phases	No additional cost
		Build internal grid as underground cable	To be considered in investment cost

Project activity	Environmental Concern	Mitigation Measures	Estimated Cost (EUR)
Detailed planning and construction phase	Health and safety risks	Availability of an adequate health and safety plan	To be included in investment cost

Project activity	Environmental Concern	Mitigation Measures	Estimated Cost (EUR)
Construction phase	Health and safety risks	Assignment of health and safety engineer of Contractor with independency with regard to giving health and safety instructions.	Included in investment cost
		Keeping the “Environmental, Health and Safety Guidelines for Wind Energy “(IFC 2007) as a minimum condition.	Included in investment cost
		Availability and proper utilisation of safety tools and equipment.	Included in investment cost
		Hygienic temporary sanitary facilities.	Included in investment cost
		Assure stoppage of erection works during weather conditions beyond safety limits.	Included in investment cost; extended erection periods
	Pollution	Good workmanship and housekeeping to be assured by supervising engineers to assure adequate disposal of solid waste and waste water and to avoid or to collect spillages of used oils, greases, diesel, etc.	Included in investment cost
		At the end of construction works: Force the contractor to put the construction site into tidy conditions, to backfilled excavations, to level heaps of excavation material and to dispose off waste adequately.	Included in investment cost
	Flora, fauna (except birds) and habitats	Restrict all activities to the boundaries of the construction areas, storage positions and access roads/tracks. Any use of the surroundings must be strictly avoided.	Very limited additional cost for investors, that can be quantified after detailed design is done only
		Avoid establishing spots that might attract animals.	No additional cost
	Birds	Restrict all activities to the boundaries of the construction areas, storage positions and access roads/tracks. Any use of the surroundings must be strictly avoided.	Very limited additional cost for investors, that can be quantified after detailed design is done only
		Avoid establishing spots that might attract birds.	No additional cost
		Build internal grid as underground cable.	To be considered in investment cost

Project activity	Environmental Concern	Mitigation Measures	Estimated Cost (EUR)
Operation and maintenance phase	Health and safety risks	Assure that operation and maintenance at wind turbines is carried out by personnel only that have passed a safety training course.	Standard requirement to be observed by project owners and monitored by a qualified external expert (50,000 EUR for a larger wind farm)
	Birds	Execution of an effective SOD-program at each individual wind farm in spring to reduce collision risk for large soaring birds.	175,000 € to 200,000 € per 50 MW wind farm and year
		Avoid or minimize lighting of wind turbines.	No additional cost
		Avoid establishing areas that might attract birds.	No additional cost
		Carry out a comprehensive post construction bird monitoring at each individual wind farm for at least the first three years during spring (carcass searches and standardized observations) and autumn (carcass searches only) to identify any impacts on migrating birds beyond acceptable level and to apply additional mitigation measures or improve already established mitigation measures, wherever necessary, to the limits defined in this study (adaptive management).	375,000 € to 400,000 € per 50 MW wind farm for three years (can probably be reduced if two or three 50 MW wind farms will be surveyed synchronously)
		Conduct yearly workshops to share data and experiences with regards to the SOD-program and the post-construction monitoring at each individual wind farm. Jointly discuss the conclusions and the need for further mitigation measures or adjustments.	To be considered by each individual owner or to be covered by responsible authorities
	Pollution	Assure proper management of domestic waste at service buildings and of used grease and oils (recycling).	Standard requirement to be observed by owners

Project activity	Environmental Concern	Mitigation Measures	Estimated Cost (EUR)
Decommission phase	Land-use and landscape	Remove the wind turbine installations at the end of the life time.	To be borne by the investor and to be considered in the investment cost

7.2 Monitoring Arrangements and Actions

The purpose of environmental monitoring is to ensure that the designed mitigation measures are implemented on the ground and then whether they are effective over the time. The latter is especially relevant with regard to the protection of migratory soaring birds and respective post-construction monitoring.

The environmental monitoring follows the management plan and shall be carried out in four phases:

1. bidding and planning phase
2. implementation and operation phase
3. checking and corrective actions phase
4. management review phase

Two monitoring activities have to be initiated for the proposed project. The first is compliance monitoring and the second is impact detection monitoring. Compliance monitoring provides for the control of keeping the postulations defined in the ESMP. The impact detection monitoring comprises mainly the post-construction monitoring on migrating birds. Also the keeping of health and safety standards to be implemented by the owners qualified health and safety engineer, acting in his field independent from eventual instructions of the owner, should be monitored by an external expert. A corresponding budget shall be considered in the cost estimate.

The responsibility for monitoring lies with the Competent Authority. Moreover, the financing institutes may make keeping the monitoring and a corresponding reporting a condition in the financing agreements.

Final Declaration

This report was prepared using the degree of skill and care ordinarily exercised by professionals practicing under similar circumstances. The report has been prepared subject to particular scope limitations, budgetary and time constraints. Information and data provided by others may not have been independently verified. Information and data contained in this deliverable are time sensitive, changes in the data, applicable codes, standards, and acceptable practices may invalidate the findings of this deliverable. Any use or reliance upon this report by third parties shall be at their sole risk.

References

- Al-Hasani, I. K. (2014): Gabel Al-Zayt Wind Farm Project (220 MW) - Post-Construction Monitoring For Non-Operational Windfarm. Report to Egyptian Environmental Affairs Agency (EEAA) & BirdLife International/UNDP/GEF Migratory Soaring Birds Project in cooperation with New and Renewable Energy Authority (NREA), Egypt.
- Al-Hasani, I. K. & M. Al-Mongy (2016): Gabel El Zayt wind farm project (200 MW) post-construction fatality monitoring. Report for Egyptian Environmental Affairs Agency (EEAA) & BirdLife International/UNDP/GEF Migratory Soaring Birds Project.
- Alerstam, T. (1990): Bird migration. Cambridge University Press., Cambridge.
- Ayyad, M. & S. Ghabour (1993). Habitat Diversity and vegetation. In: Kassas, M. (ed.): Habitat Diversity, Egypt. Publications of National Biodiversity Unit. No. 1, Cairo, pp. 5–28.
- Baha El Din, M. (1999): Directory of Important Bird Areas in Egypt. BirdLife International. The Palm Press. Cairo. 113 p.
- Baha El Din, S. M. (1999): Directory of important bird areas in Egypt. The Palm Press. Cairo. 113p.
- Baha El Din, M. (2006): A guide to the reptiles and amphibians of Egypt. American University Press. Cairo. New York. 359 p.
- Band, W., M. Madders & D. P. Whitfield (2007): Developing field and analytical methods to assess avian collision risk at wind farms. In: de Lucas, M., G. F. Janss & M. Ferrer (Hrsg.): Birds and Wind Farms. Risk Assessment and Mitigation. Quercus, Madrid: 259-275.
- Barclay, M. R., E. F. Baerwald & J. C. Gruver (2007): Variation in bat and bird fatalities at wind energy facilities: assessing the effects of rotor size and tower height. Canadian Journal of Zoology. 85 (3): 381-387.
- Barrios, L. & A. Rodriguez (2004): Behavioural and environmental correlates of soaring-bird mortality at on-shore wind turbines. Journal of Applied Ecology 41: 72-81.
- Bergen, F. (2007): Ornithological Investigation on Bird-Wind Power Interactions at a Wind Farm near Zafarana, Egypt. Report to DECON - Deutsche Energie-Consult Ingenieurgesellschaft mbH & New and Renewable Energy Authority (NREA). Dortmund.
- Bergen, F. (2009): Expert Opinion on the Additional Ornithological Investigation in Zone II (Orange Zone) as part of the Feasibility Study for a large wind farm at the Gulf of Zayt, Egypt. Final report for MVV decon GmbH. Dortmund.
- Bergen, F. & L. Gaedicke (2013): Final Report on the Bird Migration Study at the Gulf of Suez (300 km² area) at Ras Ghareb in the Arab Republic of Egypt. Report for New & Renewable Energy Authority (NREA). Dortmund.
- Bergen, F., L. Gaedicke & S. Wernitz (2016): Environmental and Social Impact Assessment Report for the 200 MW wind farm project near Ras Ghareb in the Arab Republic of Egypt. Report for Abu Dhabi Future Energy Company PJSC - Masdar. Dortmund.
- Bevanger, K., S. Clausen, Ø. Flagstad, A. Follestad, J. O. Gjershaug, D. Halley, F. Hanssen, P. Lunf Hoel, K.-O. Jacobsen, L. Johnsen, R. May, T. Nygård, H. C. Pedersen, O. Reitan, Y. Steinhaim & R. Vang (2008): Pre- and post-construction studies of conflicts between birds and wind turbines in coastal Norway. Progress Report 2008. NINA Report 409: 1-55.
- Bevanger, K., S. Clausen, Ø. Flagstad, A. Follestad, J. O. Gjershaug, D. Halley, F. Hanssen, P. Lunf Hoel, K.-O. Jacobsen, L. Johnsen, R. May, T. Nygård, H. C. Pedersen, O. Reitan, Y. Steinhaim & R. Vang (2010): Pre- and post-construction studies of conflicts between birds and

- wind turbines in coastal Norway (Bird-Wind). Report on findings 2007-2010. NINA Report 620: 1-154.
- Birdlife International (2017): BirdLife's online World Bird Data Zone. IBA Factsheet EG031 Gebel El Zeit. <http://datazone.birdlife.org/site/factsheet/gebel-el-zeit-iba-egypt> (downloaded on June 1st, 2017)
- Birdlife International (2015a): Guidance on appropriate means of impact assessment of electricity power grids on migratory soaring birds in the Rift Valley / Red Sea Flyway. Regional Flyway Facility. Amman, Jordan.
- Birdlife International (2015b): Review and guidance on use of "shutdown-on-demnad" for wind turbines to conserve migrating soaring birds in the Rift Valley/red Sea Flyway. Regional Flyway Facility. Amman, Jordan.
- Boulos, L. (2005). Flora of Egypt. Al Hadara Publishing, Cairo.
- Breuer, W. (2001): Ausgleichs- und Ersatzmaßnahmen für Beeinträchtigungen des Landschaftsbilds. Vorschläge für Maßnahmen bei Errichtung von Windkraftanlagen. Naturschutz und Landschaftsplanung 33 (8): 237-245.
- Cabrera-Cruz, S. A. & R. Villegas-Patracca (2016): Response of migrating raptors to an increasing number of wind farms. Journal of Applied Ecology: <http://dx.doi.org/10.1111/1365-2664.12673>.
- California Energy Commission (2002): Golden Eagles In A Perilous Landscape: Predicting The Effects Of Mitigation For Wind Turbine Blade-Strike Mortality. Consultant Report prepared for Public Interest Energy Research (PIER) - Environmental Area. 52 pp. + Appendices.
- Carlbro (2009): Preliminary Draft. Bird Migration Study El Zayt, Egypt. Report from bird migration studies autumn 2008 and spring 2009. Report for Italgen - Italcementi Group.
- Carlbro (2010): Bird Migration Study El Zayt, Egypt. Report from bird migration studies autumn 2008 and spring 2009. Report for Italgen - Italcementi Group.
- Chamberlain, D. E., M. R. Rehfisch, A. D. Fox, M. Desholm & S. J. Anthony (2006): The effect of avoidance rates on bird mortality predictions made by wind turbine collision risk models. Ibis 148 (Suppl. 1): 198-202.
- de Lucas, M., G. F. E. Janss & M. Ferrer (2004): The effects of a wind farm on birds in a migration point: the Strait of Gibraltar. Biodiversity and Conservation 13: 395-407.
- de Lucas, M., G. F. E. Janss, D. P. Whitfield & M. Ferrer (2008): Collision fatality of raptors in wind farms does not depend on raptor abundance. Journal of Applied Ecology 45: 1695-1703.
- Decon & Fichtner (2007): Feasibility Study for a Large Wind Farm at the Gulf of Suez. Final Report to New and Renewable Energy Authority (NREA). Bad Homburg.
- Desholm, M. (2006): Wind farm related mortality among avian migrants - a remote sensing study and model analysis. PhD thesis. Dept. of Wildlife Ecology and Biodiversity, National Environmental Research Institute and Center for Macroecology, Institute of Biology, University of Copenhagen.
- Desholm, M. & J. Kahlert (2005): Avian collision risk at an offshore wind farm. Biology letters 1 (3): 296-298.
- Desholm, M. (2006): Wind farm related mortality among avian migrants - a remote sensing study and model analysis. PhD thesis. Dept. of Wildlife Ecology and Biodiversity, National Environmental Research Institute and Center for Macroecology, Institute of Biology, University of Copenhagen.

- Dirksen, S., A. L. Spaans, J. van der Winden & L. M. J. van den Bergh (1998): Nachtelijke vliegpatronen en vlieghoogtes van duikeenden in het IJsselmeergebied. *Limosa* 71: 57-68.
- Drewitt, A. L. & R. H. W. Langston (2006): Assessing the impacts of wind farms on birds. *Ibis* 148: 29-42.
- EcoConServ (2015): Bird Migration at the 200 MW (KfW) Windfarm in Gabal El Zeit, Egypt (Autumn 2014 Season). Report to New and Renewable Energy Authority (NREA). Cairo.
- EcoConServ (2016): Alfa Wind Project: Environmental and Social Impact Assessment. 2nd Draft Report. 11. August 2016
- ecoda (2007): Ornithological Expert Opinion as a part of the Feasibility Study for a large wind farm at Gulf of Zayt, Egypt. Report for DECON - Deutsche Energie-Consult Ingenieurgesellschaft mbH. Dortmund.
- ecoda (2011): Expert Opinion on the Ornithological Investigation at the Gulf of Suez as part of the ESIA for 1,000 MW Wind Farms at Gulf of Suez, Arab Republic of Egypt. Report for New and Renewable Energy Authority (NREA) and Kreditanstalt für Wiederaufbau (KfW). Dortmund.
- ecoda (2013): Final Report on the Bird Migration Study at the Gulf of Suez (300 km² area) at Ras Gharib in the Arab Republic of Egypt. Report for New and Renewable Energy Authority (NREA). Dortmund.
- ecoda (2016a): Final Report on the Bird Migration Study for 50 MW wind farms at Ras Ghareb in the Arab Republic of Egypt. Report for Alfanar. Dortmund.
- ecoda (2016b): Final Report on the Bird Migration Study for 100 MW wind farms at Ras Ghareb in the Arab Republic of Egypt. Report for 5 Capitals Environmental and Management Consulting. Dortmund.
- EEAA – Egyptian Environmental Affairs Agency (2009): Guidelines of Principles and Procedures for Environmental Impact Assessment. 2nd Edition.
- EEAA (Ministry of State for Environmental Affairs Egyptian Environmental Affairs Agency) (2013): Environmental Impact Assessment Guidelines and Monitoring Protocols for Wind Energy Development Projects along the Rift Valley/Red Sea Flyway with particular reference to wind energy in support of the conservation of Migratory Soaring Birds (MSB). Partners: Global Environment Facility, Birdlife International, United Nations Development Program (UNDP) Egypt, Ministry of State for Environmental Affairs in Egypt, Nature Conservation Egypt. Cairo.
- EEAA – Egyptian Environmental Affairs Agency (2015): Clearing House Mechanism of Egypt, National Biodiversity Strategy and Action Plan (NBSAP) - NCS -. http://www.egyptchm.info/?page_id=796.
- El Ghazi, A. & F. Franchimont (2001): Evaluation de l'impact du parc éolien d'Al Koudia Al Baïda (Peninsule Tingitane, Maroc) sur l'avifaune migratrice post-nuptiale. GOMAC & ABIES, Gardouch,
- Erickson, W. P., G. D. Johnson, M. D. Strickland, D. P. Y. Jr., K. J. Sernka & R. E. Good (2001): Avian Collisions with Wind Turbines: A Summary of Existing Studies and Comparisons to Other Sources of Avian Collision Mortality in the United States. Report by Western EcoSystems Technology, Inc. for National Wind Coordinating Committee,
- European Commission (2010): Wind energy developments and Natura 2000. EU Guidance on wind energy development in accordance with the EU nature legislation.

- Everaert, J., K. Devos & E. Kuijken (2002): Windturbines en vogels in Vlaanderen. Voorlopige onderzoeksresultaten en buitenlandse bevindingen. Rapport Instituut voor Natuurbehoud. R.2002.03. Brussel. 76 pp.
- Everaert, J. & E. W. M. Stienen (2007): Impact of wind turbines on birds in Zeebrugge (Belgium). Significant effect on breeding tern colony due to collisions. *Biodiversity and Conservation* 16 (12): 3345-3359.
- Follestad, A., Ø. Flagstad, T. Nygard, O. Reitan & J. Schulze (2007): Wind power and birds at Smøla 2003-2006. - Norsk institutt for naturforskning, NINA Report 248. 78 pp.
- Forsman, D. (2016): The raptors of Europe and the Middle East. A Handbook to Field Identification. Poyer. London.
- Fouda, M. (2006): Protected Areas of Egypt : towards the future.
https://portals.iucn.org/library/sites/library/files/styles/publication/public/book_covers/BC-2006-048.jpg
- Fox, A. D., M. Desholm, J. Kahlert, T. K. Christensen & I. K. Petersen (2006): Information needs to support environmental impact assessment of the effects of European marine offshore wind farms on birds. *Ibis* 148: 129-144.
- Harhash, K. A., El-Henawy, M. T., Abdel Fattah, H. F. & M. S. Antar (2015): Conservation oriented habitat classification scheming and mapping of Egypt. *Environmental Systems Research* 4: 8. DOI 10.1186/s40068-015-0034-1
- Hessischer Landtag (2012): Hessisches Energiezukunftsgesetz vom 21. November 2012. Gesetz- und Verordnungsblatt für das Land Hessen 23: 444-448.
- Hilgerloh, G. (2009): The desert at Zait Bay, Egypt: a bird migration bottleneck of global importance. *Bird Conservation International* 19: 338-352.
- Hoath, R. (2003): A field guide to the mammals of Egypt. American University Press. Cairo. New York. 236 p.
- Hodos, W. (2003): Minimization of Moition Smear: reducing Avian Collisions with Wind Turbines. Sub-contractor Report. Maryland.
- Howell, J. A. & J. E. Di Donato (1991): Assessment of the avian use and mortality related to wind turbine operations: Altamont Pass, Alameda and Contra Costa Counties, California. Final Report prepared for Kenentech Windpower.
- Hunt, G. (1995): A Pilot Golden Eagle Population Study in the Altamont Pass Wind resource Area California. Report for National Renewable Energy Laboratory. Santa Cruz.
- Hüppop, O., J. Dierschke, K.-M. Exo, E. Fredrich & R. Hill (2006): Bird migration studies and potential collision risk with offshore wind turbines. *Ibis* 148: 90-109.
- IFC - International Finance Cooperation (2007): Environmental, Health, and Safety (EHS) Guidelines. General EHS Guidelines: Occupational Health and Safety.
- IFC - International Finance Cooperation (2015): Good Practice Handbook Cumulative Impact Assessment and Management: Guidance for the Private Sector in Emerging Markets. Pennsylvania. 102 p.
- IUCN (2017). The IUCN Red List of Threatened Species. <http://www.iucnredlist.org/> (downloaded on June 1st, 2017).
- Grünkorn, T., J. Blew, T. Coppack, O. Krüger, G. Nehls, A. Potiek, M. Reichenbach, J. von Rönn, H. Timmermann & S. Weitekamp (2016): Ermittlung der Kollisionsraten von (Greif)Vögeln und Schaffung planungsbezogener Grundlagen für die Prognose und Bewertung des Kollisionsrisikos durch Windenergieanlagen (PROGRESS). Schlussbericht zum durch das Bundesministerium für Wirtschaft und Energie (BMWi)

im Rahmen des 6. Energieforschungsprogrammes der Bundesregierung geförderten Verbundvorhaben PROGRESS, FKZ 0325300A-D.

- Janss, G. (2000): Bird Behaviour In and Near a Wind Farm at Tarifa, Spain: Management Considerations. In: National Wind Coordinating Committee (NWCC): Proceedings of the National Avian - Wind Power Planning Meeting III. San Diego.
- Johnson, G. D., W. P. Erickson, M. D. Strickland, M. F. Shepherd & D. A. Shepherd (2000): Avian monitoring studies at the Buffalo Ridge, Minnesota Wind Resource Area: results of a 4-year study. Final report. Northern States Power Company, Minneapolis.
- JV LI & ecoda – Joint Venture Lahmeyer International GmbH & ecoda Environmental Consultants (2011): Environmental and Social Impact Assessment for 1,000 MW wind farms at the Gulf of Suez. Final Report on behalf of New and Renewable Energy Authority (NREA). Bad Vilbel. 327 p.
- JV LI & ecoda – Joint Venture Lahmeyer International GmbH & ecoda Environmental Consultants (2013): Environmental and Social Impact Assessment for an Area of 300 km² at the Gulf of Suez. Final Report on behalf of New and Renewable Energy Authority (NREA). Bad Vilbel. 111 p. + Annexes.
- Kassas, M. A. (1993): Habitat Diversity, Egypt. Publications of National Biodiversity Unit. No. 1, Cairo.
- Krijgsveld, K. L., K. Akershoek, F. Schenk, F. Dijk & S. Dirksen (2009): Collision risk of birds with modern large wind turbines. ARDEA 97 (3): 357-366.
- Langgemach, T. & T. Dürr (2015): Informationen über Einflüsse der Windenergienutzung auf Vögel – Stand 01.06.2015. Staatliche Vogelschutzwarte des Landesamts für Umwelt, Gesundheit und Verbraucherschutz Brandenburg, Nennhausen.
- Langston, R. H. W., A. D. Fox & A. L. Drewitt (2006): Conference plenary discussion, conclusions and recommendations. Ibis 148: 210-216.
- Langston, R. H. W. & J. D. Pullan (2004): Effects of wind farms on birds. Nature and environment, no 139. Council of Europe Publishing, Strasbourg.
- Lekuona, J. M. & C. Ursúa (2007): Avian mortality in wind power plants of Navarra (Northern Spain). In: de Lucas, M., G. F. E. Janss & M. Ferrer (Hrsg.): Birds and Wind Farms. Risk Assessment and Mitigation. Quercus, Madrid.
- Lesham, Y. & Y. Yom-Tov (1996): The Magnitude and timing of migration by soaring raptors, pelicans and storks over Israel. Ibis 138: 188-203.
- Madders, M. & D. P. Whitfield (2006): Upland raptors and the assessment of wind farm impacts. Ibis 148: 43-56.
- Marques, A. T., H. Batalha, S. Rodrigues, H. Costa, M. J. R. Pereira, C. Fonseca, M. Mascarenhas & J. Bernardino (2014): Understanding bird collisions at wind farms: An updated review on the causes and possible mitigation strategies. Biological Conservation 179: 40-52.
- Masden, E. A. & A. S. C. P. Cook (2016): Avian collision risk models for wind energy impact assessments. Environmental Impact Assessment Review 56: 43-49.
- Masden, E. A., D. T. Haydon, A. D. Fox, R. W. Furness, R. Bullman & M. Desholm (2009): Barriers to movement: impacts of wind farms on migrating birds. ICES Journal of Marine Science 66: 746-753.
- Meyburg, B.-U., D. H. Ellis, C. Meyburg, J. M. Mendelsohn & W. Scheller (2001): Satellite tracking of two Lesser Spotted Eagles, *Aquila pomarina*, migrating from Namibia. Ostrich 72: 35-40.

- Meyburg, B.-U., M. Gallardo, C. Meyburg & E. Dimitrova (2004a): Migrations and sojourn in Africa of Egyptian vultures (*Neophron percnopterus*) tracked by satellite. *Journal of Ornithology* 145: 273-280.
- Meyburg, B.-U., J. Matthes & C. Meyburg (2002): Satellite-tracked Lesser Spotted Eagle avoids crossing water at the Gulf of Suez. *British Birds* 95: 372-376.
- Meyburg, B.-U. & C. Meyburg (2007): Quinze années de suivi de rapaces par satellite. *Alauda* 75 (3): 265-286.
- Meyburg, B.-U., C. Meyburg, T. Belka, O. Sreibr & J. Vrana (2004b): Migration, wintering and breeding of a lesser spotted eagle (*Aquila pomarina*) from Slovakia tracked by satellite. *Journal of Ornithology* 145: 1-7.
- Meyburg, B.-U., C. Meyburg & P. Paillat (2012): Steppe Eagle migration strategies – revealed by satellite telemetry. *British Birds* 105: 506-519.
- Meyburg, B.-U., P. Paillat & C. Meyburg (2003): Migration routes of steppe eagles between Asia and Africa: a study by means of satellite telemetry. *The Condor* 105: 219-227.
- Morrison, M. L., K. C. Sinclair & C. G. Thelander (2007): A sampling framework for conducting studies of the influence of wind energy developments on birds and other animals. In: de Lucas, M., G. F. E. Janss & M. Ferrer (Hrsg.): *Birds and Wind Farms. Risk Assessment and Mitigation*. Quercus, Madrid.
- Orloff, S. & A. Flannery (1992): Wind turbine effects on avian activity, habitat use, and mortality in Altamont Pass and Solano County Wind Resource Areas 1989 - 1991. Final Report by BioSystems Analysis, Inc. to California Energy Commission.
- Ornis Consult (1999): Biodiversity review of the western Gulf of Suez. Prepared by M. Baha El Din & F. P. Jensen. Copenhagen, Denmark.
- Ornis Consult (2002): Atlas of bird migration at the Gulf of Suez, Egypt. Ministry of Foreign Affairs. DANIDA. Copenhagen, Denmark.
- Osborn, R. G., K. F. Higgins, R. E. Usgaard, C. D. Dieter & R. D. Neiger (2000): Bird mortality associated with wind turbines at the Buffalo Ridge Wind Resource Area, Minnesota. *The American Midland Naturalist* 143: 41-52.
- Osborn D. J. & I. Helmy (1980): The contemporary land mammals of Egypt (including Sinai). Published by Field Museum of Natural History. New Series, No. 5.
- Percival, S. M. (2000): Birds and wind turbines in Britain. *British Wildlife* 12: 8-15.
- Percival, S. (2005): Birds and windfarms: what are the real issues? *British Birds* 98: 194-204.
- Saleh, M. A. (1993): Habitat Diversity and Land Vertebrates. In: Kassas, M. (ed.): *Habitat Diversity, Egypt*. Publications of National Biodiversity Unit. No. 1, Cairo, pp. 165–131.
- Saleh, M. (1997): *Amphibians and reptiles of Egypt*. Publications of National Biodiversity Unit. No. 6: 234 pp.
- Said, R. (ed.) (1990): *The Geology of Egypt*. 734 pp. Rotterdam. Brookfield.
- Shamoun-Baranes, J., A. Baharad, P. Alpert, P. Berthold, Y. Yom-Tov, Y. Dvir & Y. Leshem (2003): The effect of wind, season and latitude on the migration speed of white storks *Ciconia ciconia*, along the eastern migration route. *Journal of Avian Biology* 34 (1): 97-104.
- Shamoun-Baranes, J., E. Van Loon, D. Alon, P. Alpert, Y. Yom-Tov & Y. Leshem (2006): Is there a connection between weather at departure sites, onset of migration and timing of soaring-bird autumn migration in Israel? *Global Ecology and Biogeography* (15): 541-552.

- Smallwood, K. S., L. Ruge & M. L. Morrison (2009): Influence of Behavior on Bird Mortality in Wind Energy Developments. *The Journal of Wildlife Management* 73 (7): 1082-1098.
- Smallwood, K. S. & C. G. Thelander (2004): Developing methods to reduce bird mortality in the Altamont Pass Wind Resource Area. Final Report by BioResource Consultants to the Energy Commission, Public Interest Energy Research-Environmental Area.
- Smallwood, K. S. & C. G. Thelander (2008): Bird mortality in the Altamont Pass Wind Resource Area, California. *Journal of Wildlife Management* 72 (1): 215-223.
- Steinborn, H. & M. Reichenbach (2011): Kranichzug und Windenergie - Zugplanbeobachtungen im Landkreis Uelzen. *Naturkundliche Beiträge Landkreis Uelzen* 3: 113-127.
- Sterner, D., S. Orloff & L. Spiegel (2007): Wind turbine collision research in the United States. In: de Lucas, M., G. F. E. Janss & M. Ferrer (Hrsg.): *Birds and Wind Farms. Risk Assessment and Mitigation*. Quercus, Madrid.
- Strickland, D., W. Erickson, D. Young & G. Johnson (2007): Selecting study design to evaluate the effect of windpower on birds. In: de Lucas, M., G. F. E. Janss & M. Ferrer (2007): *Birds and Wind Farms. Risk Assessment and Mitigation*. p. 117-136. Quercus. Madrid.
- Strix (2016): Wind turbine shutdown on demand operations and bird migration monitoring in the Gabal el Zayt Wind Farm (200 mw), Egypt. Unpublished report (Ref. t2016.2014.1, Annual Report 1, Spring 2016, June 2016). Portugal.
- Thelander, C. G. & K. S. Smallwood (2007): The Altamont Pass Wind Resource Area's effects on birds: A case history. In: de Lucas, M., G. F. E. Janss & M. Ferrer (Hrsg.): *Birds and Wind Farms. Risk Assessment and Mitigation*. Quercus, Madrid: 25-46.
- University of Newcastle (2002) Visual Assessment of Windfarms Best Practice. Scottish Natural Heritage Commissioned Report F01AA303A.
- Vanermen, N., E. W. M. Stienen, W. Courtens, T. Onkelinx, M. Van de walle & H. Verstraete (2013): Bird monitoring at offshore wind farms in the Belgian part of the North Sea. Assessing seabird displacement effects. *Rapporten van het Instituut voor Natuur- en Bosonderzoek 2013 (INBO.R.2013.755887)*. Instituut voor Natuur- en Bosonderzoek, Brussel.
- Vansteelant, W. M. G., W. Bouten, R. H. G. Klaassen, B. J. Koks, A. E. Schlaich, J. van Diermen, E. E. van Loon & J. Shamoun-Baranes (2015): Regional and seasonal flight speeds of soaring migrants and the role of weather conditions at hourly and daily scales. *Journal of Avian Biology* 46 (1): 25-39.
- Vasilakis, D. P., D. P. Whitfield, S. Schindler, K. S. Poirazidis & V. Kati (2016): Reconciling endangered species conservation with wind farm development: Cinereous vultures (*Aegypius monachus*) in south-eastern Europe. *Biological Conservation* 196: 10-17.
- Vidal-Mateo, J., U. Mellone, P. López- López, J. De La Puente, C. García-Ripollés, A. Bermejo & V. Urios (2016): Wind effects on the migration routes of trans-Saharan soaring raptors: geographical, seasonal, and interspecific variation. *Current Zoology* 62 (2): 89-97
- Villegas-Patracá, R., S. A. Cabrera-Cruz & L. Herrera-Alsina (2014): Soaring Migratory Birds Avoid Wind Farm in the Isthmus of Tehuantepec, Southern Mexico. *PLoS ONE* 9 (3): e92462. doi:10.1371/journal.pone.0092462.
- Weitekamp, S., H. Timmermann & M. Reichenbach (2015): Progress – Predictive modelling versus empirical data – collision numbers in relation to flight activity in 55 German wind farm seasons. Talk on the Conference on Wind energy and Wildlife impacts. Berlin.
- Whitfield, D. P. & M. Madders (2006): Deriving collision avoidance rates for red kites *Milvus milvus*. *Natural Research Information Note 3*. Natural Research Ltd, Banchory, UK.

- Winkelman, J. E. (1992): De invloed van de Sep-proefwindcentrale te Oosterbierum (Fr.) op vogels, 1: aanvaringsslchtoffers. RIN-rapport 92/2. DLO-Instituut voor Bos- en Natuuronderzoek, Arnhem.
- Zahran M. A. & Willis A. J. (2009): The Eastern Desert. In: The Vegetation of Egypt. Plant and Vegetation, Vol 2. Springer, Dordrecht.
- Zaharan, M. (2010): Climate–Vegetation; Afro-Asian Mediterranean and Red Sea Coastal Lands. Springer Science.

Annex

- Annex I: Target species, which are known to migrate along Egypt
- Annex II: Explanation of different categories of “The IUCN Red List of Threatened Species” for migratory bird species in Egypt
- Annex III: List of experts who were involved over large periods in the monitoring of migratory soaring birds
- Annex IV: Species factsheets for autumn and spring migration
- Annex V: Numbers of birds/records (rec) registered at the 14 observation sites (1 to 14) in
- a. autumn 2016
 - b. spring 2016
 - c. spring 2017
- Annex VI: Potential effects of operating wind farms on migratory soaring birds
- Annex VII: “Sensitivity Search” by application of the Soaring Bird Sensitivity Map Tool (BirdLife International)

Strategic and Cumulative Environmental and Social Assessment

Active Turbine Management Program (ATMP) for Wind Power Projects in the Gulf of Suez

Annex I

Target species, which are known to migrate
along Egypt



Annex I Target species, which are known to migrate along Egypt

no	species	scientific name	IUCN Red List
1	Greater Flamingo	<i>Phoenicopterus roseus</i>	LC
2	Great White Pelican	<i>Pelecanus onocrotalus</i>	LC
3	Black Stork	<i>Ciconia nigra</i>	LC
4	White Stork	<i>Ciconia ciconia</i>	LC
5	Osprey	<i>Pandion haliaetus</i>	LC
6	European Honey Buzzard	<i>Pernis apivorus</i>	LC
7	Black Kite	<i>Milvus migrans</i>	LC
8	Egyptian Vulture	<i>Neophron percnopterus</i>	EN
9	Short-toed Snake Eagle	<i>Circaetus gallicus</i>	LC
10	Marsh Harrier	<i>Circus aeruginosus</i>	LC
11	Pallid Harrier	<i>Circus macrourus</i>	NT
12	Montagu's Harrier	<i>Circus pygargus</i>	LC
13	Levant Sparrowhawk	<i>Accipiter brevipes</i>	LC
14	Eurasian Sparrowhawk	<i>Accipiter nisus</i>	LC
15	Steppe Buzzard	<i>Buteo buteo vulpinus</i>	LC
16	Long-legged Buzzard	<i>Buteo rufinus</i>	LC
17	Lesser Spotted Eagle	<i>Aquila pomarina</i>	LC
18	Greater Spotted Eagle	<i>Aquila clanga</i>	VU
19	Steppe Eagle	<i>Aquila nipalensis</i>	EN
20	Eastern Imperial Eagle	<i>Aquila heliaca</i>	VU
21	Booted Eagle	<i>Aquila pennata</i>	LC
22	Lesser Kestrel	<i>Falco naumanni</i>	LC
23	Common Kestrel	<i>Falco tinnunculus</i>	LC
24	Red-footed Falcon	<i>Falco vespertinus</i>	NT
25	Eleonora's Falcon	<i>Falco eleonora</i>	LC
26	Sooty Falcon	<i>Falco concolor</i>	NT
27	Eurasian Hobby	<i>Falco subbuteo</i>	LC
28	Lanner Falcon	<i>Falco biarmicus</i>	LC*
29	Barbary Falcon	<i>Falco pelegrinoides</i>	LC*
30	Common Crane	<i>Grus grus</i>	LC

Classification due to IUCN Red List of Threatened Birds: “Endangered”, “Vulnerable”, “Near Threatened”

Species not considered in the IUCN Red List are not colored.

*: no classification for migratory birds available, represented category refers to breeding birds

Strategic and Cumulative Environmental and Social Assessment

Active Turbine Management Program (ATMP) for Wind Power Projects in the Gulf of Suez

Annex II

Explanation of different categories of “The IUCN Red List of Threatened Species” for migratory bird species in Egypt



Annex II Explanation of different categories of “The IUCN Red List of Threatened Species” for migratory bird species in Egypt

International Union for the Conservation of Nature and Natural Resources

<http://www.iucnredlist.org/>

http://www.birdlife.org/datazone/speciessearchresults.php?reg=0&cty=63&cri=&fam=0&gen=0&spc=&cmn=&hab=&thr=&bt=&rec=N&vag=N&sea=&wat=&aze=&lab=&enb=&mib=Y&cnv=&hdnAction=ADV_SEARCH&SearchTerms=

ENDANGERED (EN)

A species is Endangered when the best available evidence indicates that it meets any of the criteria A to E for Endangered, and it is therefore considered to be facing a very high risk of extinction in the wild.

VULNERABLE (VU)

A species is Vulnerable when the best available evidence indicates that it meets any of the criteria A to E for Vulnerable, and it is therefore considered to be facing a high risk of extinction in the wild.

NEAR THREATENED (NT)

A species is Near Threatened when it has been evaluated against the criteria but does not qualify for Critically Endangered, Endangered or Vulnerable now, but is close to qualifying for or is likely to qualify for a threatened category in the near future.

LEAST CONCERN (LC)

A species is Least Concern when it has been evaluated against the criteria and does not qualify for Critically Endangered, Endangered, Vulnerable or Near Threatened. Widespread and abundant species are included in this category.

For explanations of the mentioned criteria within the explanations of the categories see:

http://jr.iucnredlist.org/documents/redlist_cats_crit_en.pdf

http://www.iucnredlist.org/documents/reg_guidelines_en.pdf

Strategic and Cumulative Environmental and Social Assessment

Active Turbine Management Program (ATMP) for Wind Power Projects in the Gulf of Suez

Annex III

List of experts

who were involved over large periods in the monitoring of migratory soaring birds



Annex III List of experts who were involved over large periods in the monitoring of migratory soaring birds

We would like to thank all experts that took part in the monitoring of migratory soaring birds. We really acknowledge their effort in sometimes difficult situations and harsh weather conditions and we highly appreciate their support.

Calin Hodor

Emanuel Stefan Baltag

Istvan Moldovan

Manuel Flores Lunar

Markus Frenzel

Michael Boetzel

Mihail-Victor Hutuleac-Volosciuc

Oliver Giesecke

Petrisor Galan

Szilard Zsolt Ölvedi

Thorsten Zegula

Tim Korschefsky

Wael M. Shohdi

Wed Abdou

Strategic and Cumulative Environmental and Social Assessment

Active Turbine Management Program (ATMP) for Wind Power Projects in the Gulf of Suez

Annex IV

Species factsheets on autumn and spring migration



Annex IV Species factsheets for autumn and spring migration

This annex contains additional information about those target species, of which at least ten individuals (during autumn or spring migration period) were recorded in the study area (i.e. at distances of up to 2.5 km to the observation sites). This comprises the following species:

- Great White Pelican (*Pelecanus onocrotalus*)
- Black Stork (*Ciconia nigra*)
- White Stork (*Ciconia ciconia*)
- European Honey Buzzard (*Pernis apivorus*)
- Black Kite (*Milvus migrans*)
- Egyptian Vulture (*Neophron percnopterus*)
- Short-toed Snake Eagle (*Circaetus gallicus*)
- Marsh Harrier (*Circus aeruginosus*)
- Pallid Harrier (*Circus macrourus*)
- Montagu's Harrier (*Circus pygargus*)
- Levant Sparrowhawk (*Accipiter brevipes*)
- Eurasian Sparrowhawk (*Accipiter nisus*)
- Steppe Buzzard (*Buteo buteo vulpinus*)
- Long-legged Buzzard (*Buteo rufinus*)
- Lesser Spotted Eagle (*Aquila pomarina*)
- Greater Spotted Eagle (*Aquila clanga*)
- Steppe Eagle (*Aquila nipalensis*)
- Eastern Imperial Eagle (*Aquila heliaca*)
- Booted Eagle (*Aquila pennata*)
- Common Kestrel (*Falco tinnunculus*)
- Common Crane (*Grus grus*)

Note:

- In the given figures a similar scaling of the axis for autumn and spring migration of a certain species is chosen to allow direct comparison of data.
- A different scaling of the axis was chosen for different species.
- As records (a total of 19 records (28 birds) in autumn 2016) of Sooty Falcon (*Falco concolor*) probably referred to local birds, no species-specific data is presented here.
- The data refers to the study area (i.e. the area at distances of up to 2.5 km to the observation sites). Nevertheless, as the 284 km² project area is more important for the assessment, the bordering of the project area is shown in the figures,
- In autumn and spring 2016 the survey did not cover the complete migration period of all target species. Thus, data for these two seasons does not offer a full picture of species-specific migratory activity or seasonal and temporal migration patterns.
- As the spent effort (observational times) and the covered study periods show remarkably differences in spring 2016 and 2017, the presented species-specific data does not allow a direct comparison of migratory activity (e. g. the total number) in the two seasons. However, results from spring 2016 and spring 2017 consistently show that bird migration in the study area is highly variable in time and space.

Great White Pelican

Great White Pelican *Pelecanus onocrotalus*

IUCN-Red List: Least Concern

Flyway Population (individuals): 70,000

	autumn 2016		spring 2016		spring 2017	
	birds	records	birds	records	birds	records
study area	244	3	3,015	12	770	8
overall	244	3	4,095	15	5,963	11

1. Seasonal Migration Pattern (Phenology)

The species was recorded occasionally in autumn in spring. In autumn three flocks were recorded. During spring 2016 the majority of birds were recorded between mid of April and beginning of May. Most birds were recorded within one large flock of 2,000 birds, which passed the study area on May 1st, 2016. In spring 2017 the majority was registered in the first half of May.

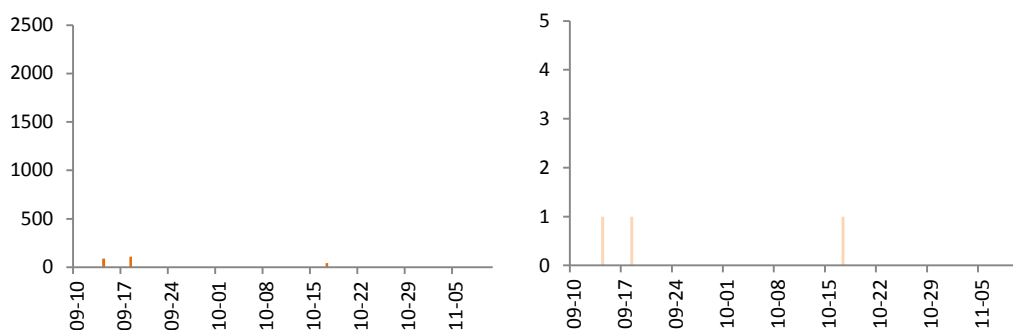

Number of birds (left) and records (right) registered in the study area in **autumn 2016**

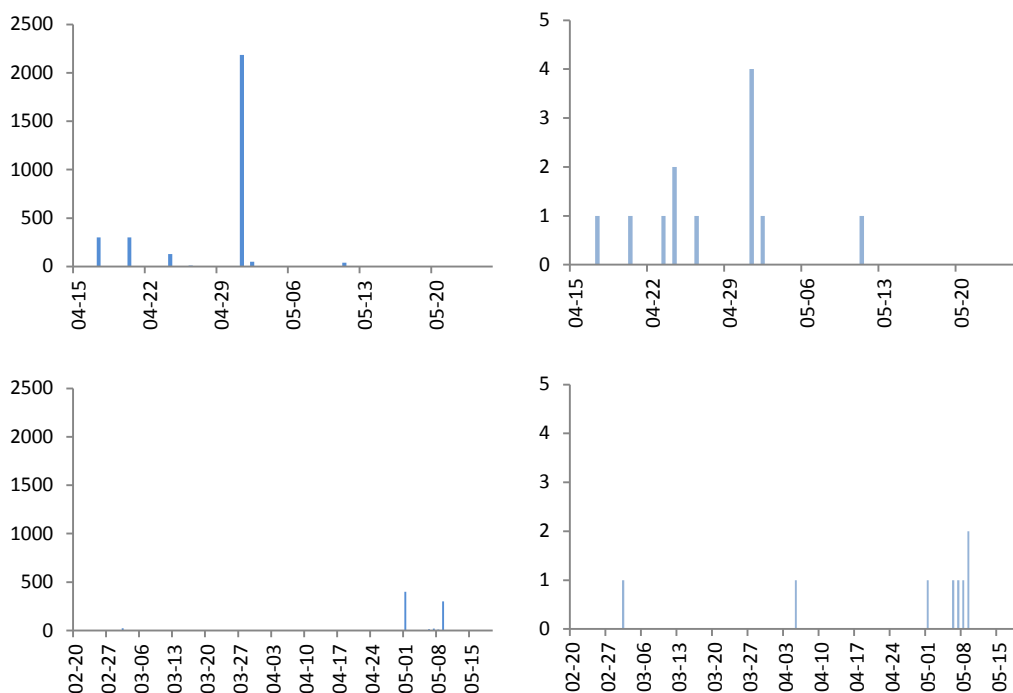

Number of birds (left) and records (right) registered in the study area in **spring 2016** (above) and **2017** (below)

Great White Pelican

2. Flight altitude

In autumn the registered individuals were recorded above 120 m and thus above risk height (i.e. > 30 to 120 m). The recorded flock of 2,000 individuals in spring 2016 roosted before continuing migration. The birds flew at a low height (and stayed within low height during the observation). Against this background most birds in spring 2016 were recorded below the risk height (even though the birds probably entered the risk height later). During spring 2017 all birds - and thus a significant part of the flyway population - were recorded at least temporarily at risk height, i.e. > 30 to 120 m.

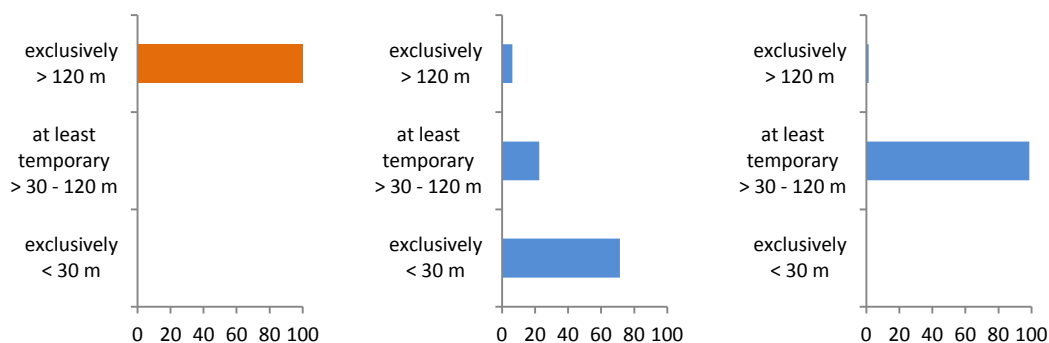

Relative abundance (percentage) of birds recorded at different altitude classes in the study area in **autumn 2016** (n=244; left), **spring 2016** (n=3,015; middle) and **2017** (n=770; right)



Great White Pelicans

Great White Pelican

3. Daily Migration Pattern

The species was recorded during various times of the day in autumn and spring.

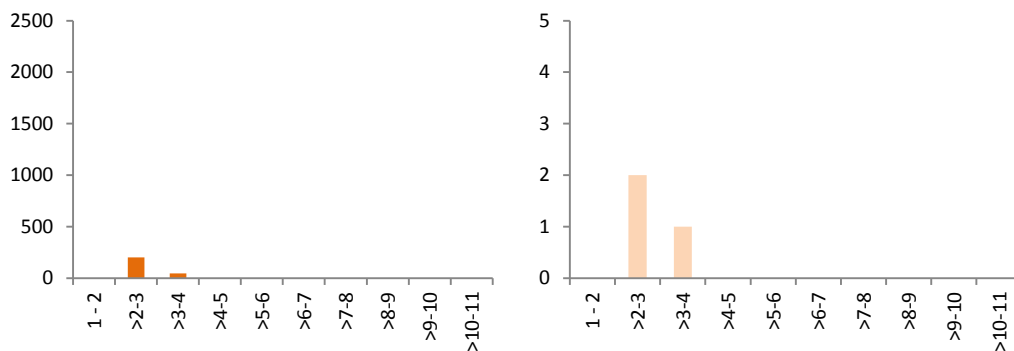

Number of birds (left) and records (right) registered in the study area at different hours after sunrise in **autumn 2016** - no observations were conducted in early morning and evening

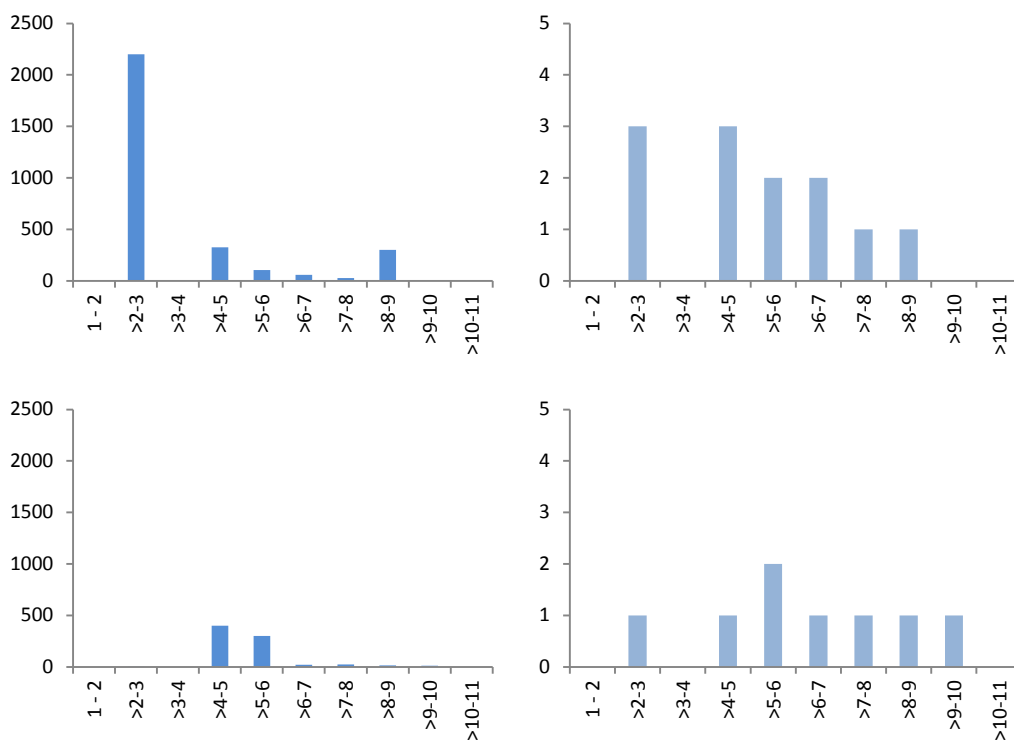

Number of birds (left) and records (right) registered in the study area at different hours after sunrise in **spring 2016** (above) and **2017** (below) - no observations were conducted in early morning and evening

Great White Pelican

4. Spatial Migration Pattern

For details about the spatial distribution of recorded Great White Pelicans see Map 3.3 and 3.8 in the Report.



Number of birds (in abundance classes) registered within the study area in **autumn 2016** (above), **spring 2016** (below left) and **2017** (below right)

Black Stork

Black Stork *Ciconia nigra*

IUCN-Red List: Least Concern

Flyway Population (individuals): 40,000

	autumn 2016		spring 2016		spring 2017	
	birds	records	birds	records	birds	records
study area	0	0	192	25	249	41
overall	0	0	205	27	249	41

1. Seasonal Migration Pattern (Phenology)

This species was recorded in spring only. Black Storks occurred between mid / end of March and beginning / mid of May. Most times smaller flocks were registered.

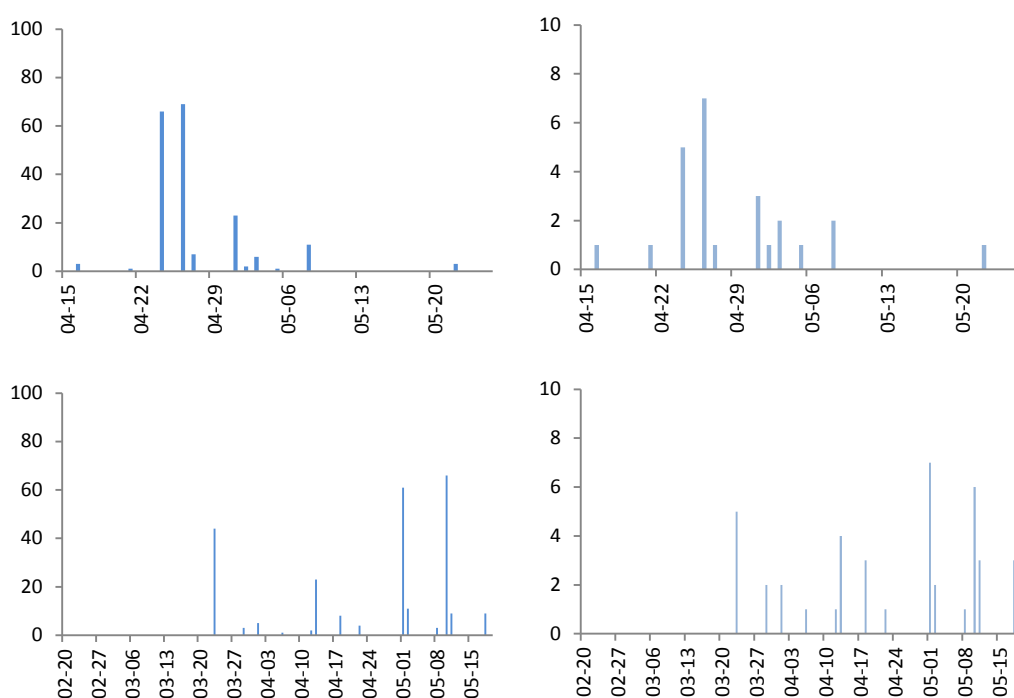

Number of birds (left) / records (right) registered in the study area in **spring 2016** (above) and **2017** (below)

2. Flight altitude

In spring 2016 most birds were recorded at altitudes above 120 m (i.e. above risk height > 30 to 120 m). In spring 2017 a nameable share (non-significant part of the flyway population) was recorded at the risk height.

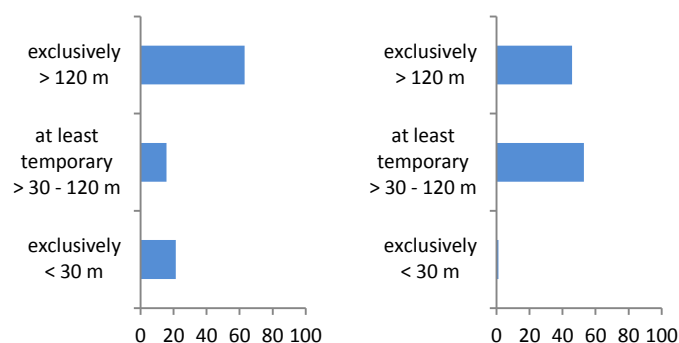

Relative abundance (percentage) of birds recorded at different altitude classes in the study area in **spring 2016** (n=192; left) and **2017** (n=249; right)

Black Stork

3. Daily Migration Pattern

The species was recorded during various times of the day in spring. By trend most birds were observed in the period after 5 hours after sunrise.

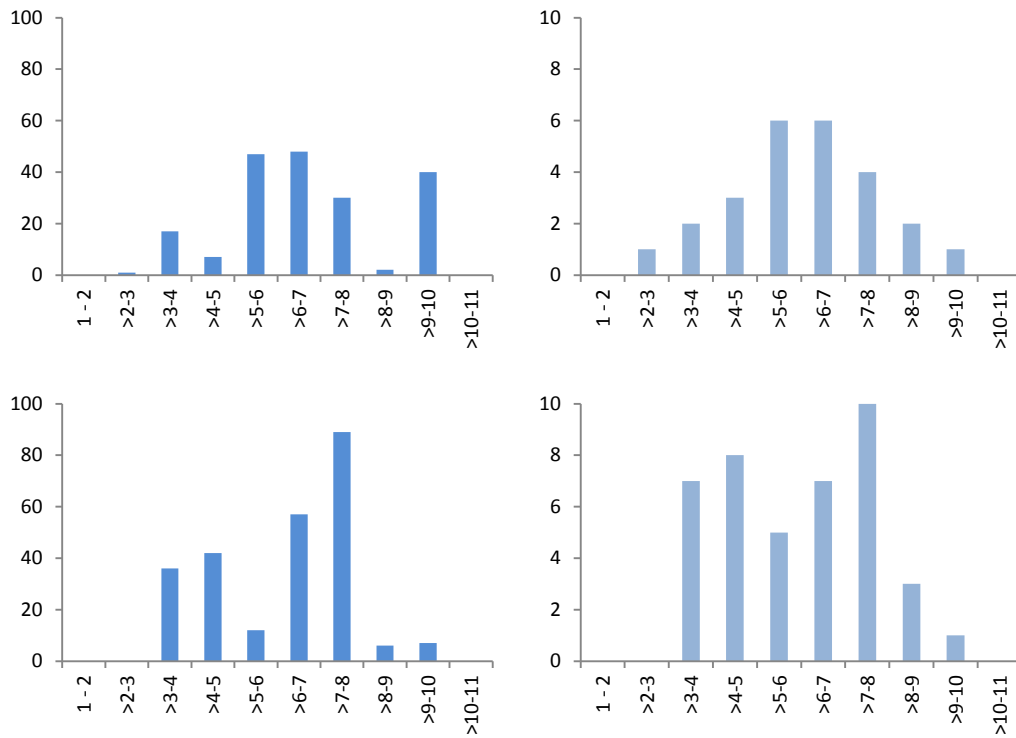

Number of birds (left) and records (right) registered in the study area at different hours after sunrise in **spring 2016** (above) and **2017** (below) - no observations were conducted in early morning and evening



Black Storks

Black Stork

4. Spatial Migration Pattern

During autumn no birds were observed. In spring, the registered number of birds differed little amongst observation sites.

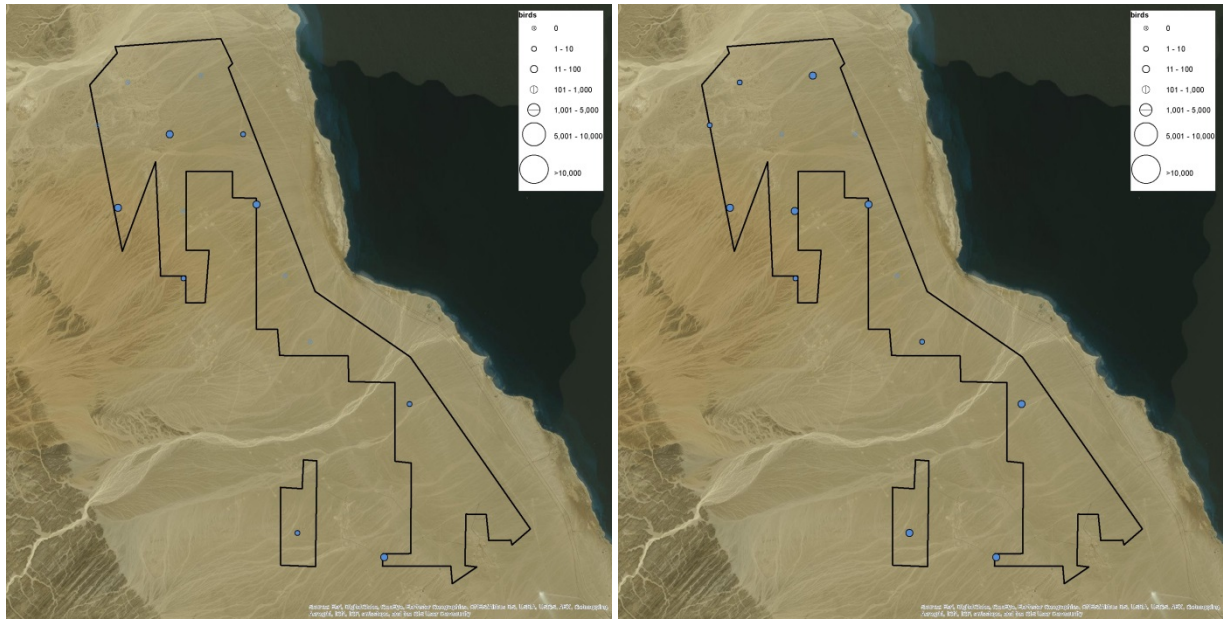

Number of birds (in abundance classes) registered within the study area in **spring 2016** (left) and **2017** (right)

White Stork

White Stork *Ciconia ciconia*

IUCN-Red List: Least Concern

Flyway Population (individuals): 400,000 - 750,000

	autumn 2016		spring 2016		spring 2017	
	birds	records	birds	records	birds	records
study area	636	5	45,559	111	93,199	150
overall	701	7	61,548	135	109,795	163

1. Seasonal Migration Pattern (Phenology)

During autumn 2016 four flocks were recorded between beginning / mid of September and beginning / mid of November. In spring 2016 most birds occurred between mid / end of April and beginning of May. During spring 2017 most birds were observed between end of March and beginning of May.

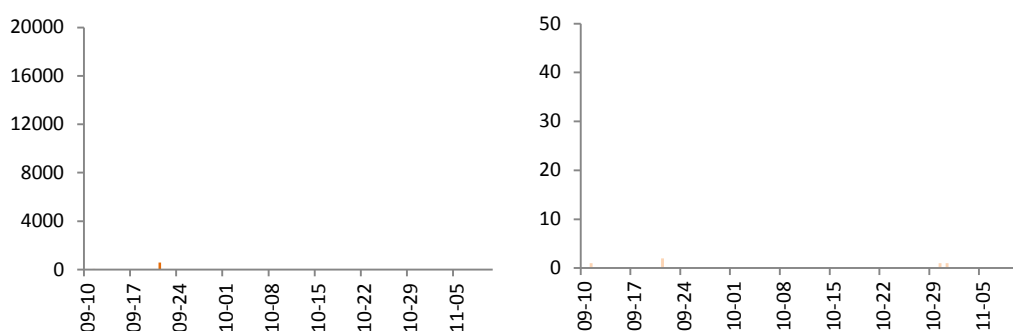

Number of birds (left) and records (right) registered in the study area in **autumn 2016**

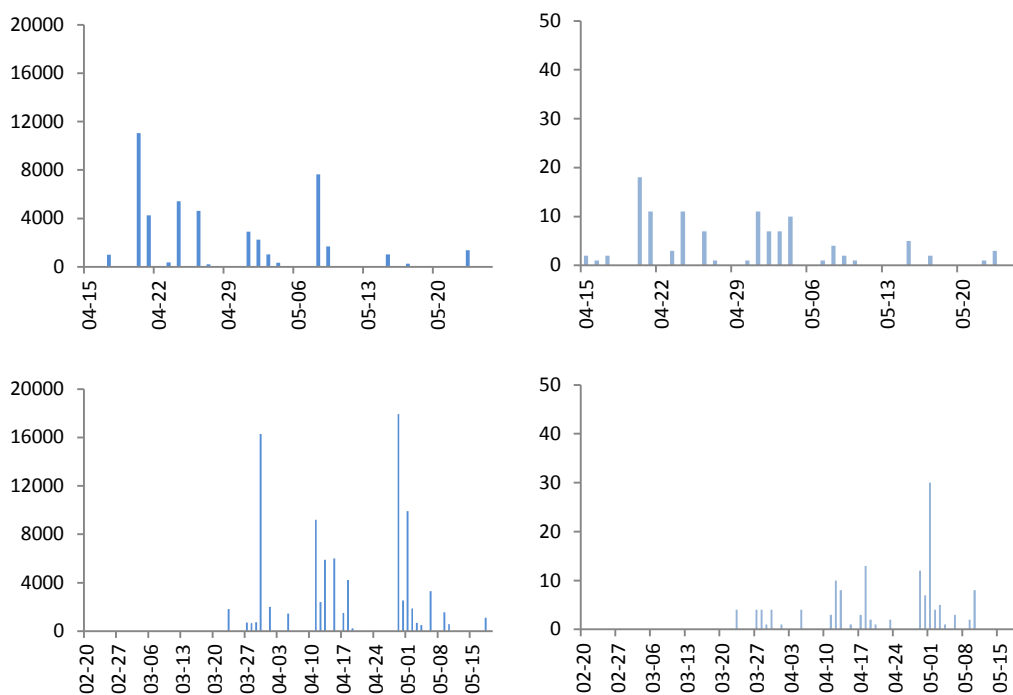

Number of birds (left) and records (right) registered in the study area in **spring 2016** (above) and **2017** (below)

White Stork

2. Flight altitude

In autumn and spring most birds were recorded at altitudes above 120 m (i.e. above risk height > 30 to 120 m). However, in spring 2016 and 2017 the number of birds migrating at risk height represented a significant part of the flyway population of this species (2.1 to 4.0 % in spring 2016 and 6.1 to 11.4 % in spring 2017).

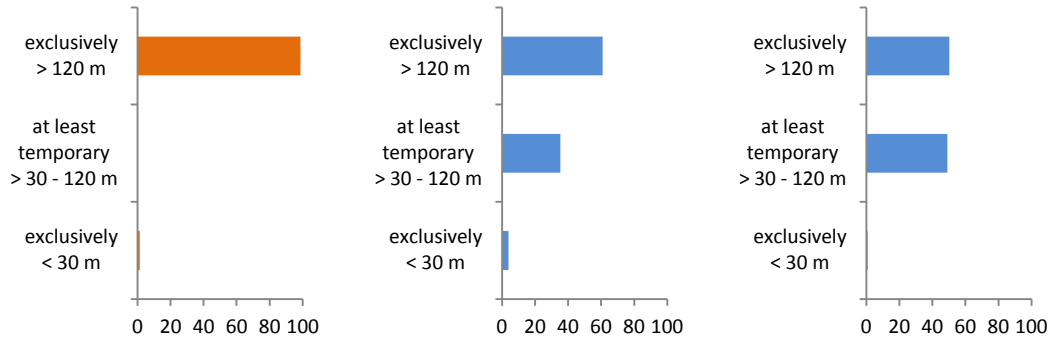

Relative abundance (percentage) of birds recorded at different altitude classes in the study area in **autumn 2016** (n=636; left), **spring 2016** (n=45,559; middle) and **2017** (n=93,199; right)



White Storks

White Stork

3. Daily Migration Pattern

During autumn 2016 four flocks were recorded during various times of the day. The daily pattern of migration in spring was highly affected by single large flocks. However, the number of birds and records point towards a peak during the time between 3 to 8 hours after sunrise in spring 2016 and 2017.

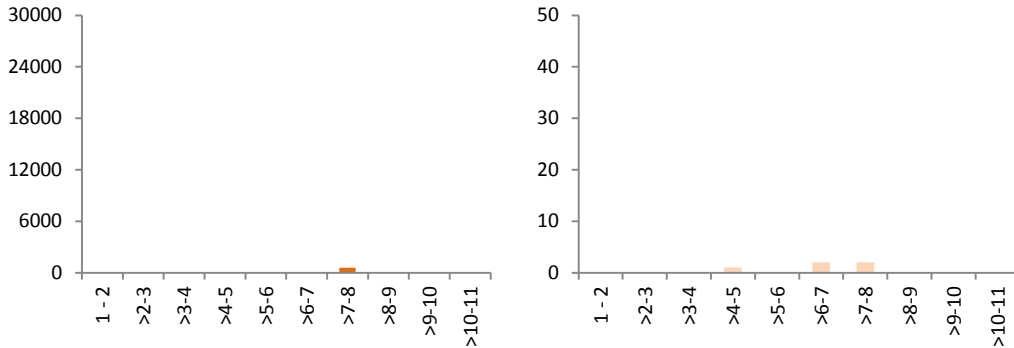

Number of birds (left) and records (right) registered in the study area at different hours after sunrise in **autumn 2016** - no observations were conducted in early morning and evening

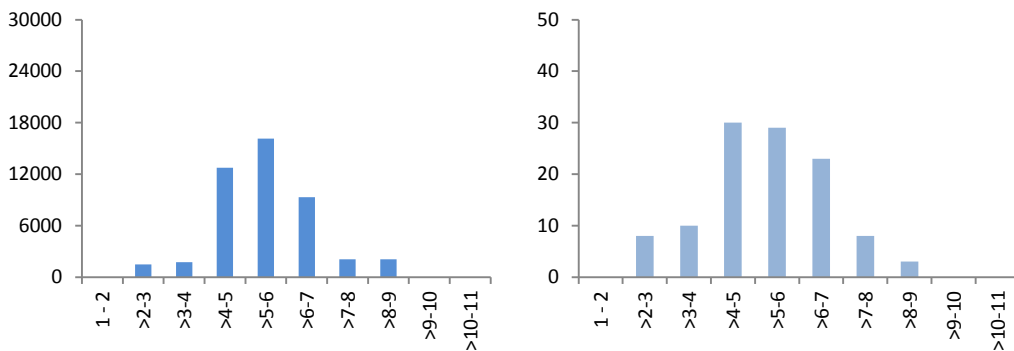

Number of birds (left) and records (right) registered in the study area at different hours after sunrise in **spring 2016** (above) and **2017** (below) - no observations were conducted in early morning and evening

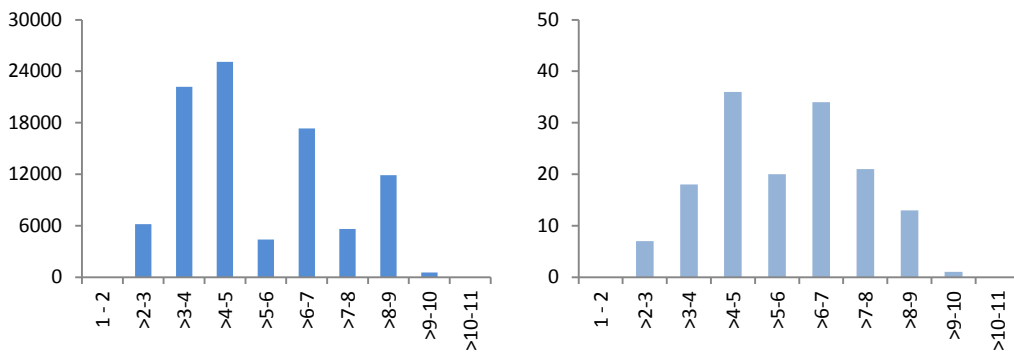

White Stork

4. Spatial Migration Pattern

For details about the spatial distribution of the recorded White Storks see Map 3.3 and 3.8 in the Report.



Number of birds (in abundance classes) registered within the study area in **autumn 2016** (above), **spring 2016** (below left) and **2017** (below right)

Osprey

Osprey *Pandion haliaetus*

IUCN-Red List: Least Concern

Flyway Population (individuals): 17,500

	autumn 2016		spring 2016		spring 2017	
	birds	records	birds	records	birds	records
study area	0	0	11	7	20	18
overall	0	0	11	7	20	18

1. Seasonal Migration Pattern (Phenology)

This species was recorded in spring only. The data at hand suggest an occurrence from mid of April to end of May. In spring 2017 most birds were recorded between mid of April and beginning of May.

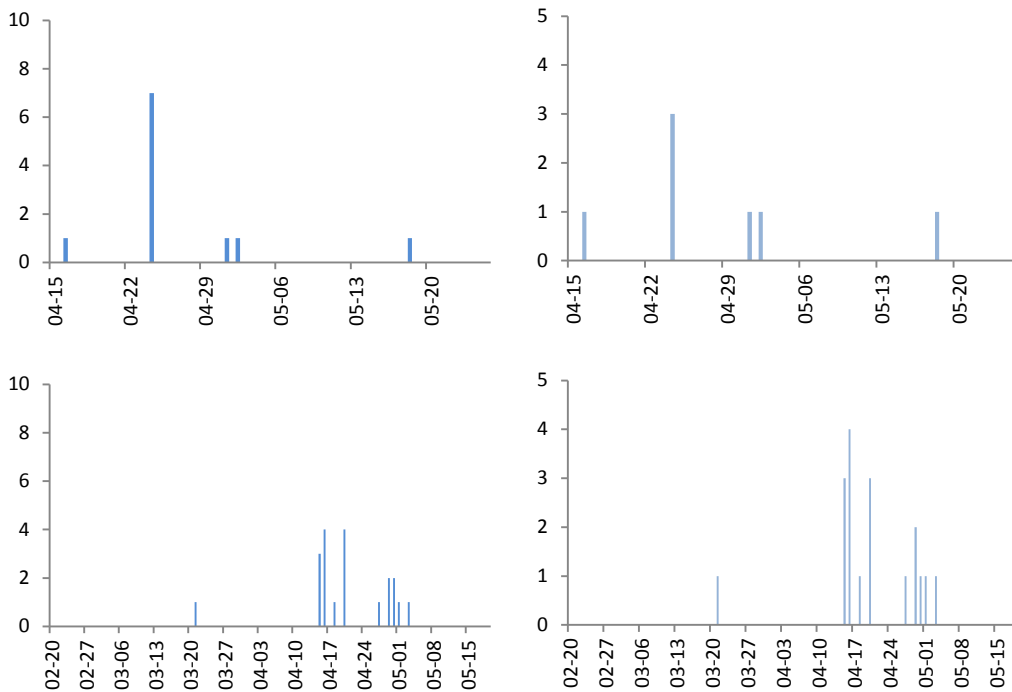

Number of birds (left) and records (right) registered in the study area in **spring 2016** (above) and **2017** (below)

Osprey

2. Flight altitude

In spring 2016 and 2017 most birds were recorded at risk height > 30 to 120 m. However, the recorded number (spring 2016 ten; spring 2017 17 birds) is clearly non-significant part of the flyway population.

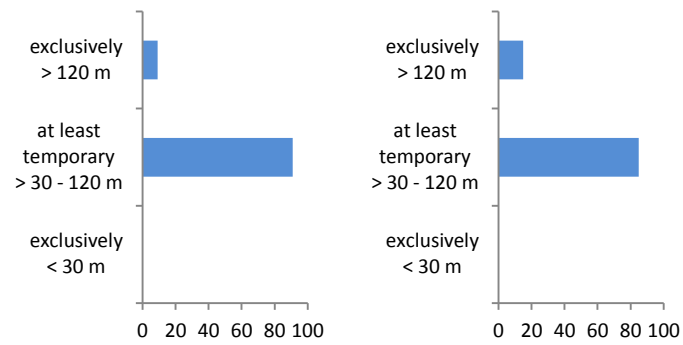

Relative abundance (percentage) of birds recorded at different altitude classes in the study area in **spring 2016** (n=11; left) and **2017** (n=20; right)



Osprey

Osprey

3. Daily Migration Pattern

Single Ospreys were observed during various times of the day in spring.

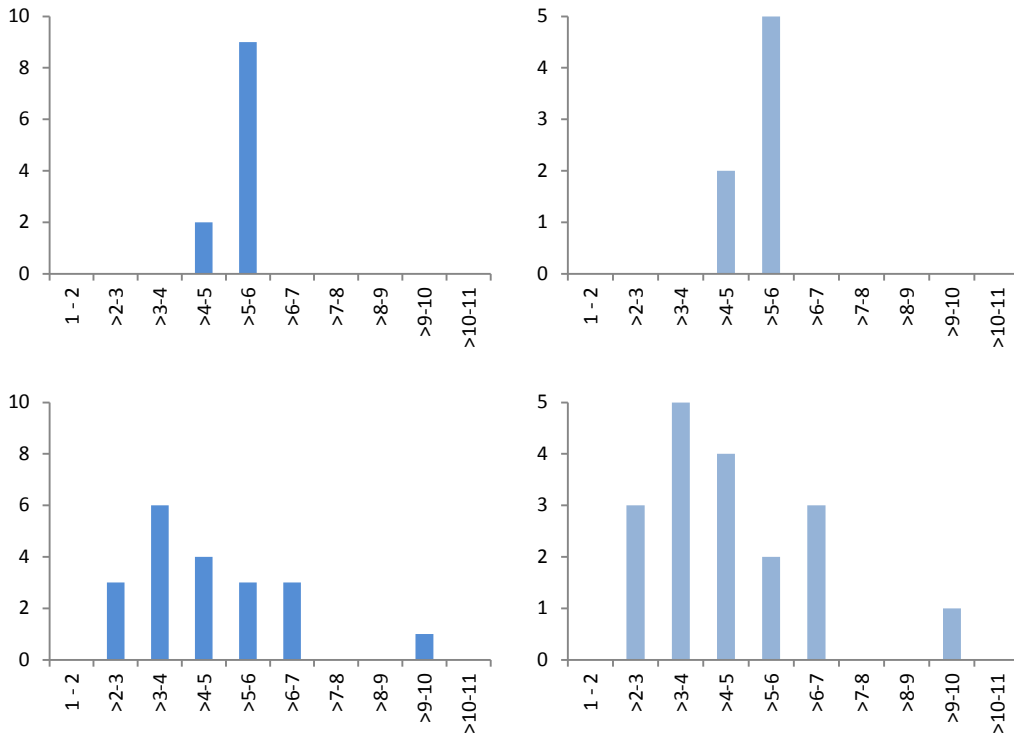

Number of birds (left) and records (right) registered in the study area at different hours after sunrise in **spring 2016** (above) and **2017** (below) - no observations were conducted in early morning and evening

4. Spatial Migration Pattern

The number of observed birds differed little between the two observation sites.

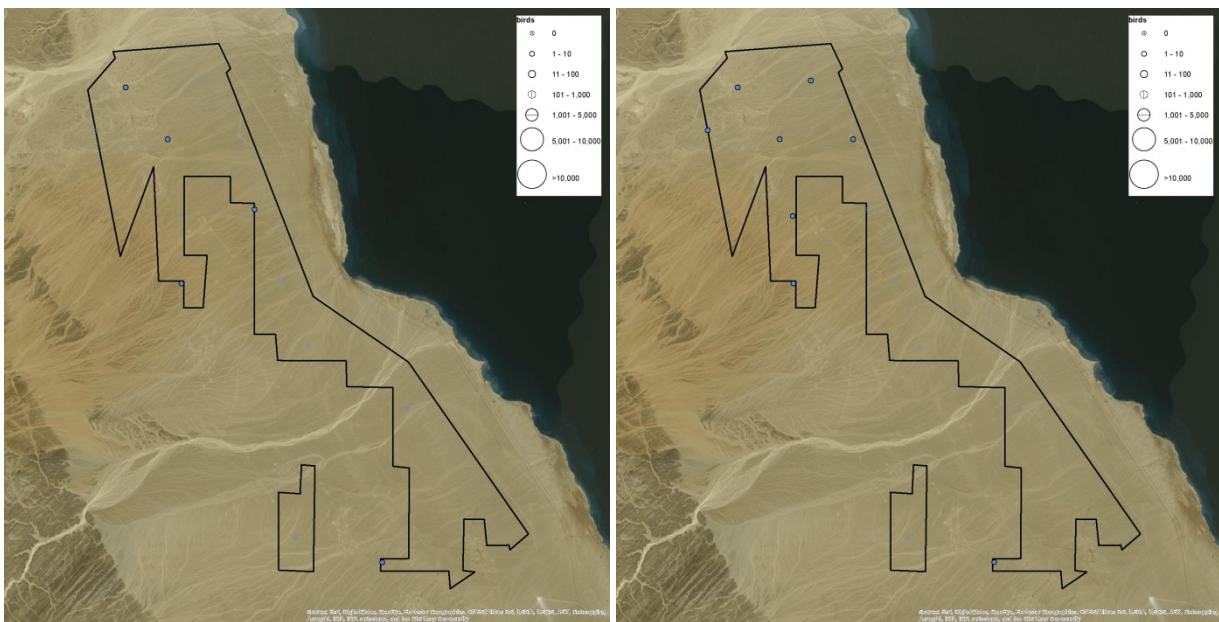

Number of birds (in abundance classes) registered within the study area in **spring 2016** (left) and **2017** (right)

European Honey Buzzard

European Honey Buzzard

Pernis apivorus

IUCN-Red List: Least Concern

Flyway Population (individuals): 1,000,000

	autumn 2016		spring 2016		spring 2017	
	birds	records	birds	records	birds	records
study area	1,335	148	10,622	263	7,531	306
overall	1,527	160	13,629	283	7,623	309

1. Seasonal Migration Pattern (Phenology)

In autumn 2016 migrating European Honey Buzzards were recorded until beginning of October. Most birds were recorded within the first seven days of the study period (pattern caused by the late start of the study period located in the middle of European Honey Buzzards main migration period).

During spring seasons migration concentrated in end of April (2016) and the first half of May (2017). In spring 2016 68 % of all birds passed on April 26th and May 3rd. On May 1st, 10th and 18th a total of about 89 % of all European Honey Buzzards observed in spring 2017 were recorded.

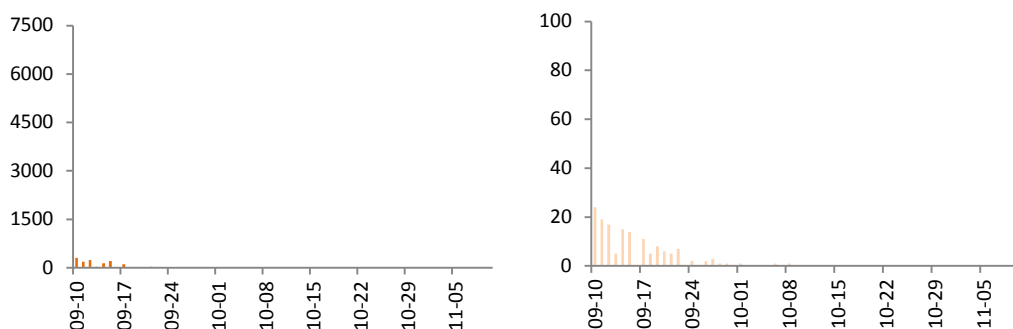

Number of birds (left) and records (right) registered in the study area in **autumn 2016**

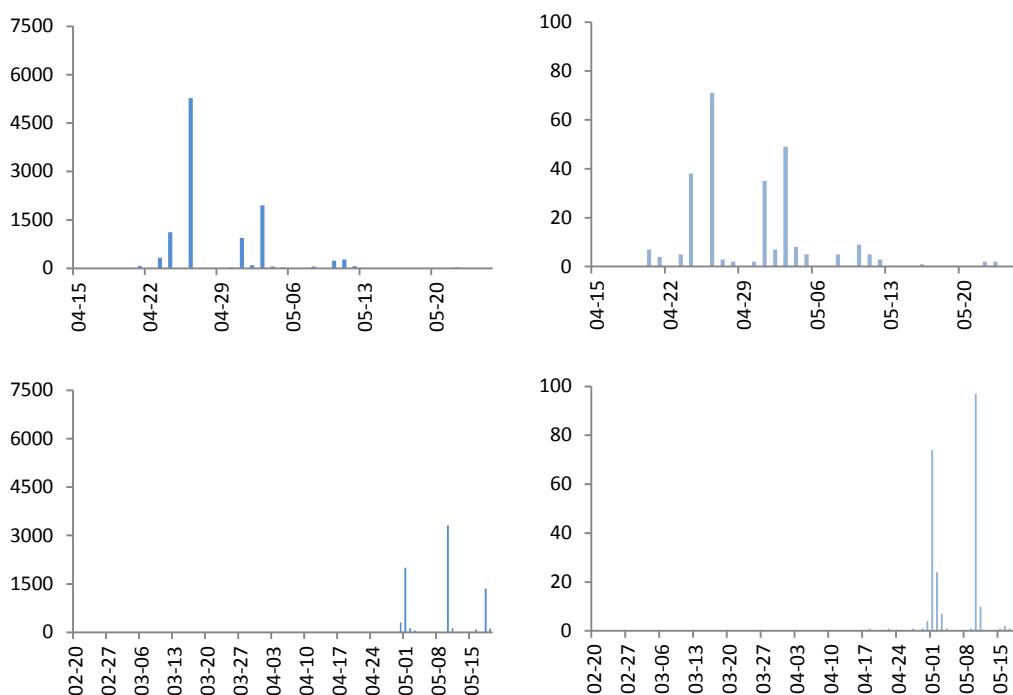

Number of birds (left) and records (right) registered in the study area in **spring 2016** (above) and **2017** (below)

European Honey Buzzard

2. Flight altitude

In autumn and spring most birds were recorded at altitudes above 120 m (i.e. above risk height > 30 to 120 m). In autumn 2016 as well as spring 2016 and 2017 a nameable share (clearly non-significant part of the flyway population in autumn; about 0.3 % in spring 2016 and 2017 each) was recorded at risk height.

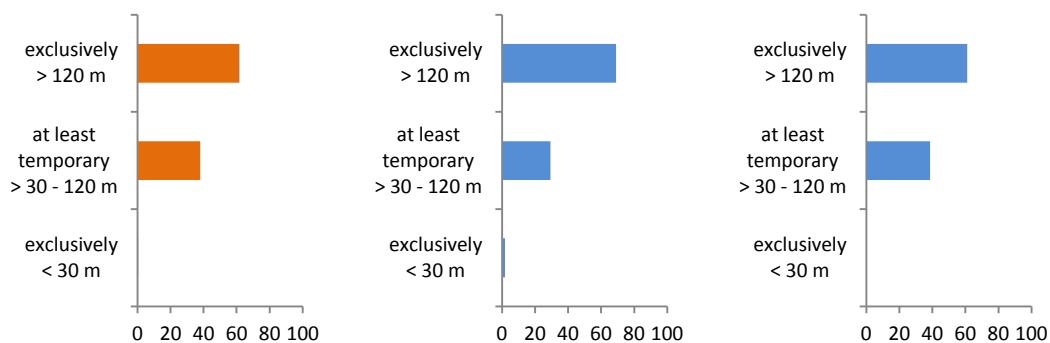

Relative abundance (percentage) of birds recorded at different altitude classes in the study area in **autumn 2016** (n=1,335; left), **spring 2016** (n=10,622; middle) and **2017** (n=7,531; right)

European Honey Buzzard

3. Daily Migration Pattern

The number of records suggests an occurrence during various times of the day in autumn. By trend the number of records suggests a decrease of the migratory activity from 4 hours after sunrise to the afternoon in spring 2016 and 2017.

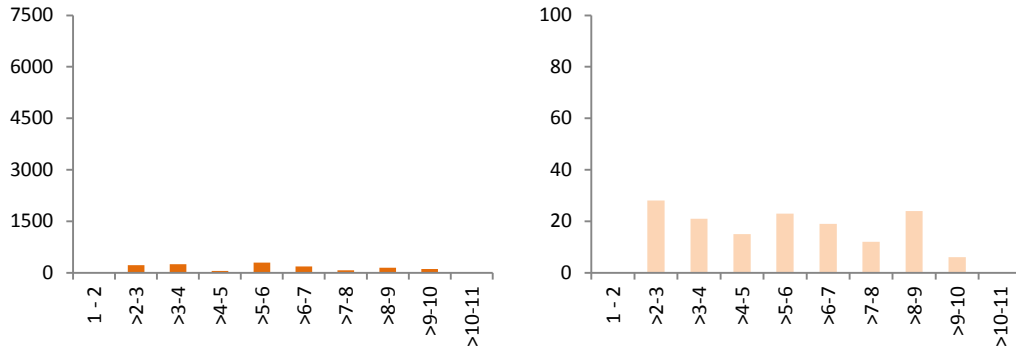

Number of birds (left) and records (right) registered in the study area at different hours after sunrise in **autumn 2016** - no observations were conducted in early morning and evening

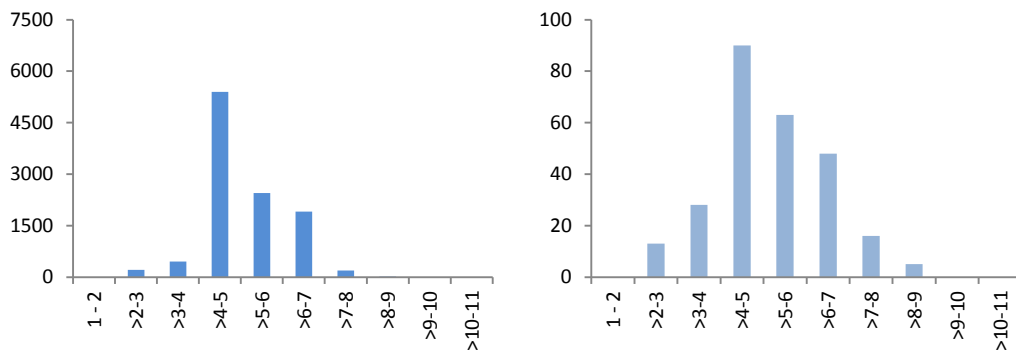

Number of birds (left) and records (right) registered in the study area at different hours after sunrise in **spring 2016** (above) and **2017** (below) - no observations were conducted in early morning and evening

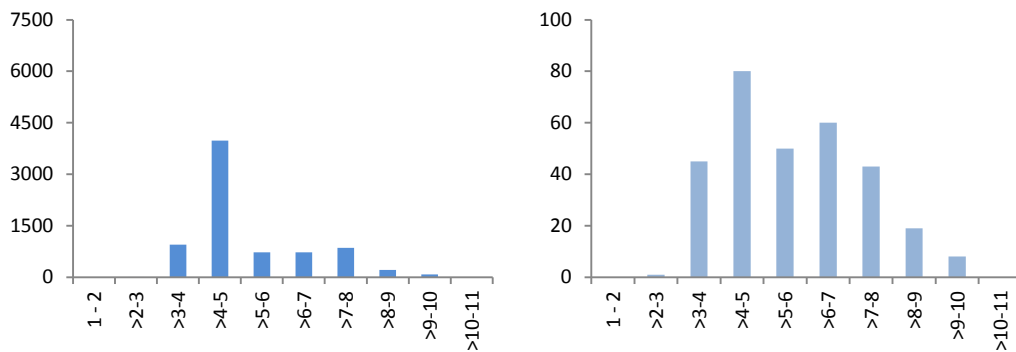

European Honey Buzzard

4. Spatial Migration Pattern

The number of observed birds differed little amongst observation sites in autumn.

For spring 2016 the figure suggests a higher migratory activity at four observation sites in the north and for spring 2017 at two observation sites in the north and one in the south. These differences were mainly caused by single observation units with higher numbers during few days (see above for details).



Number of birds (in abundance classes) registered within the study area in **autumn 2016** (above), **spring 2016** (below left) and **2017** (below right)

Black Kite

Black Kite *Milvus migrans*

IUCN-Red List: Least Concern

Flyway Population (individuals): 132,700

	autumn 2016		spring 2016		spring 2017	
	birds	records	birds	records	birds	records
study area	37	28	1,030	193	4,077	402
overall	37	28	1,081	201	4,083	403

1. Seasonal Migration Pattern (Phenology)

In autumn Black Kites were registered during almost the whole study period, but in very low numbers. In spring 2016 migration was recorded mainly from mid of April to mid of May. During spring 2017 migrating Black Kites occurred almost during the whole study period, too. However, most birds passed the study area between end of March and mid / end of April. On April 12th and 13th about 50 % of all birds were observed.

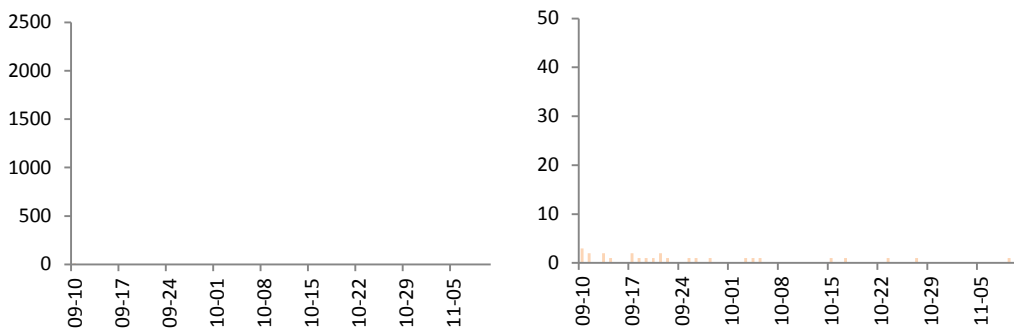

Number of birds (left) and records (right) registered in the study area in **autumn 2016**

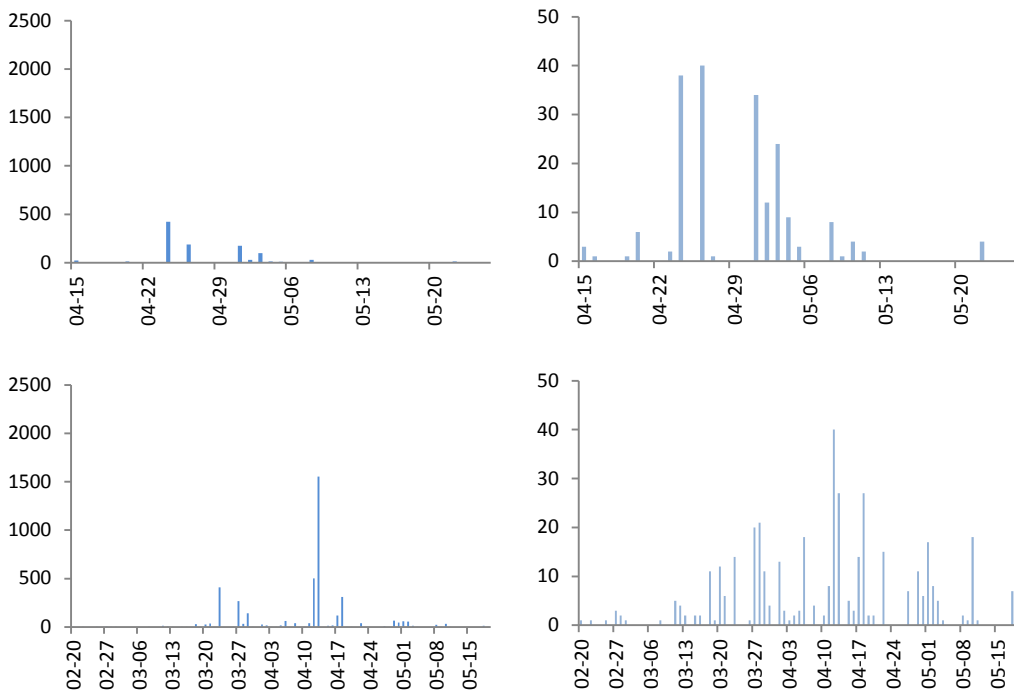

Number of birds (left) and records (right) registered in the study area in **spring 2016** (above) and **2017** (below)

Black Kite

2. Flight altitude

In spring 2016 and 2017 most birds were recorded at altitudes above 120 m (i.e. above risk height > 30 to 120 m). In autumn 2016 and spring 2017 a nameable share was recorded at risk height. In autumn this share did clearly not represent a significant proportion of the flyway population. In spring 2017 Black Kites recorded at risk height represent about 0.7 % of the flyway-population.

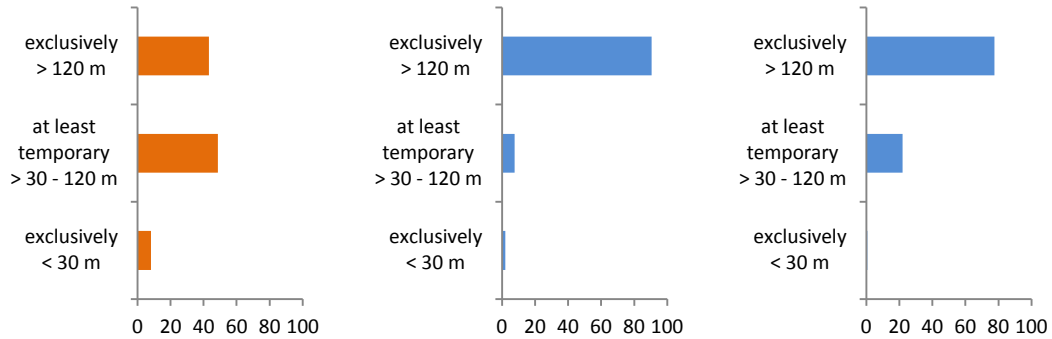

Relative abundance (percentage) of birds recorded at different altitude classes in the study area in **autumn 2016** (n=37; left), **spring 2016** (n=1,030; middle) and **spring 2017** (n=4,077; right)



Black Kite

Black Kite

3. Daily Migration Pattern

Having a look at the number of records migration occurred during various times of the day in autumn and spring. However, migratory activity in spring seemed to increase during the morning and decrease from the morning to the afternoon.

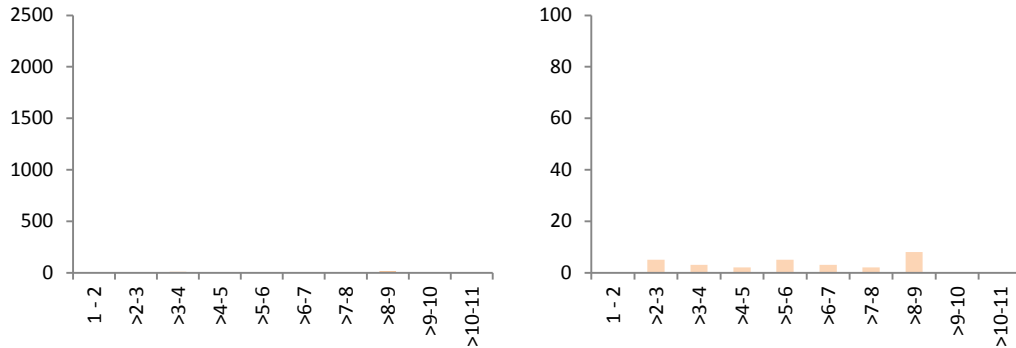

Number of birds (left) and records (right) registered in the study area at different hours after sunrise in **autumn 2016** - no observations were conducted in early morning and evening

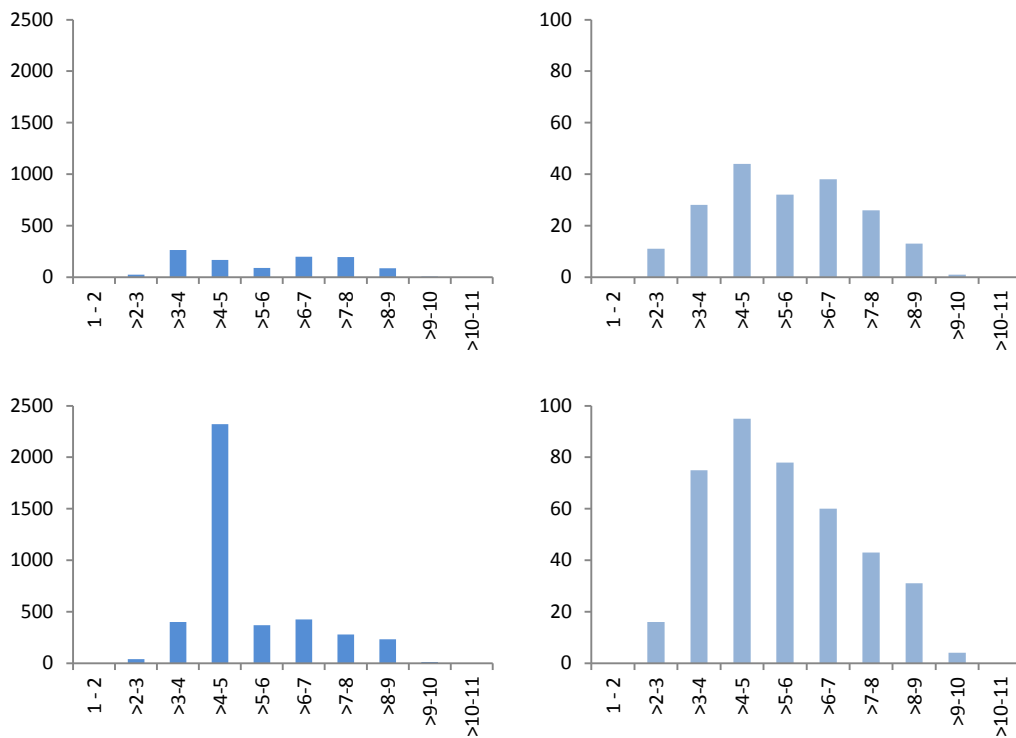

Number of birds (left) and records (right) registered in the study area at different hours after sunrise in **spring 2016** (above) and **2017** (below) - no observations were conducted in early morning and evening

4. Spatial Migration Pattern

The number of observed birds differed little amongst observation sites in autumn and spring. The higher number at one observation site in spring 2017 was caused by one observation unit on April 13th.



Number of birds (in abundance classes) registered within the study area in **autumn 2016** (above), **spring 2016** (below left) and **2017** (below right)

Egyptian Vulture

Egyptian Vulture

Neophron percnopterus

IUCN-Red List: Endangered

Flyway Population (individuals): 4,535

	autumn 2016		spring 2016		spring 2017	
	birds	records	birds	records	birds	records
study area	0	0	78	48	56	44
overall	0	0	82	52	56	44

1. Seasonal Migration Pattern (Phenology)

In autumn this species was not recorded.

During spring 2017 Egyptian Vultures were registered between mid of March and mid of May with peak in mid of April and beginning of May. In spring 2016 most birds were recorded end of April and beginning of May.

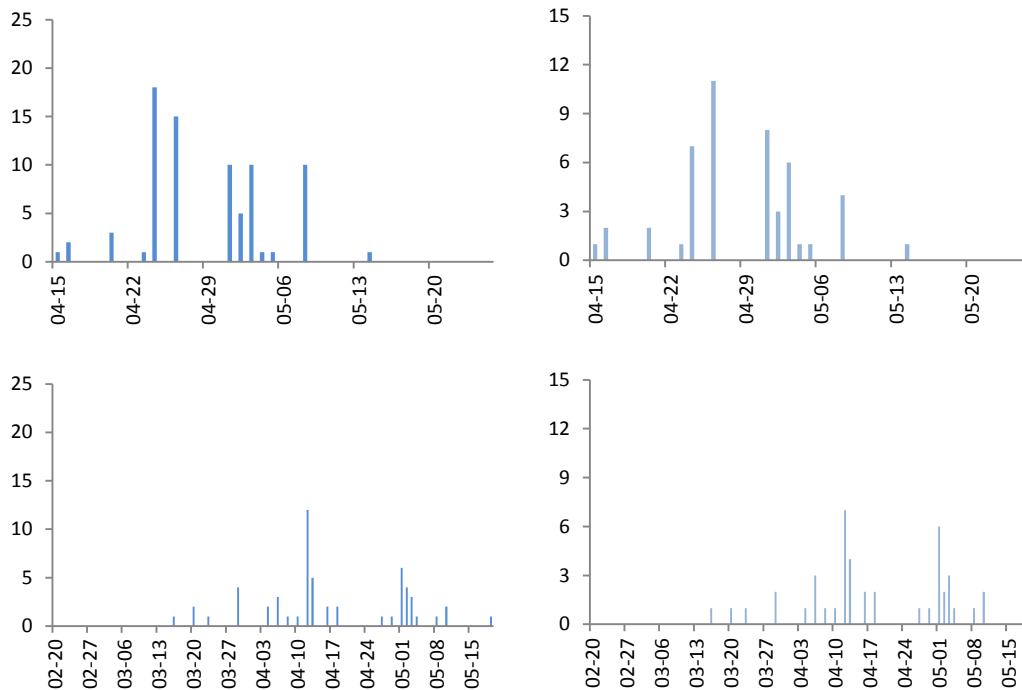

Number of birds (left) and records (right) registered in the study area in **spring 2016** (above) and **2017** (below)

Egyptian Vulture

2. Flight altitude

In spring 2016 and spring 2017 most birds were recorded above 120 m and thus above the risk height (i.e. > 30 to 120 m). The share of birds at risk height in spring 2016 was 0.1 % and in spring 2017 0.4 % of the flyway population.

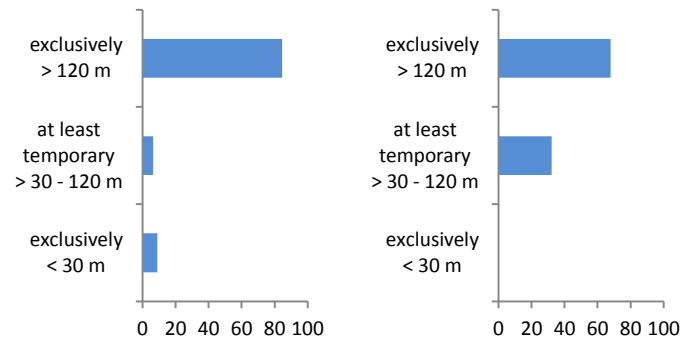

Relative abundance (percentage) of birds recorded at different altitude classes in the study area in **spring 2016** (n=78; left) and **2017** (n=56; right)



Egyptian Vulture

Egyptian Culture

3. Daily Migration Pattern

The (low) number of birds and records suggests an increase of migratory activity towards the period of 6 hours after sunrise and a decrease afterwards.

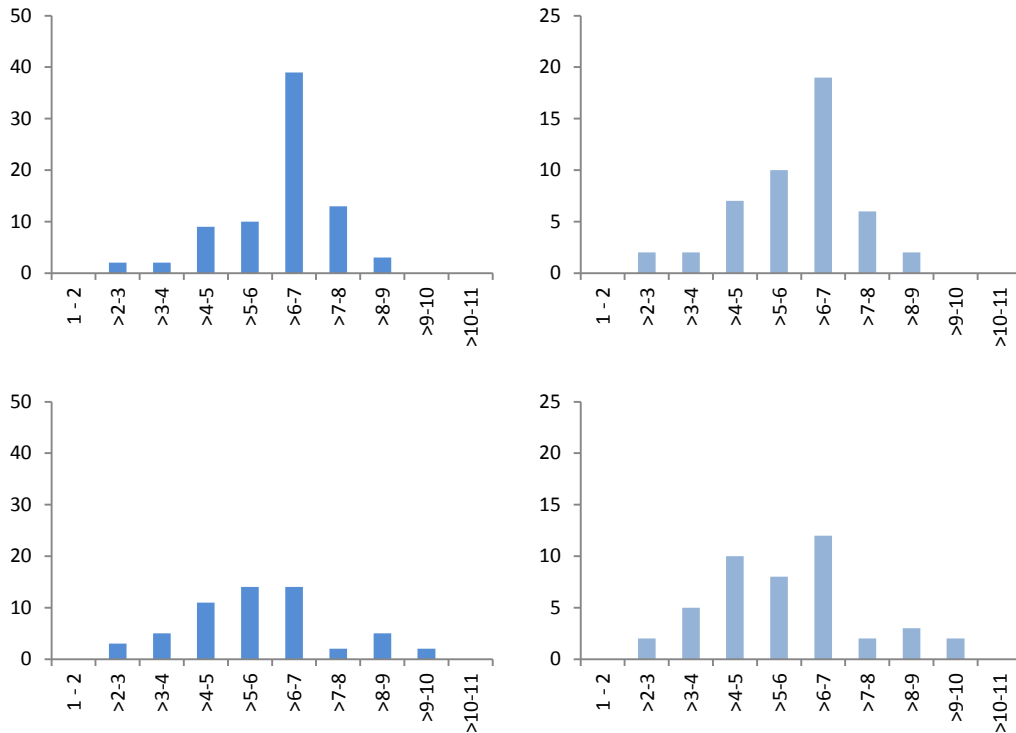

Number of birds (left) and records (right) registered in the study area at different hours after sunrise in **spring 2016** (above) and **2017** (below) - no observations were conducted in early morning and evening

4. Spatial Migration Pattern

Due to the relative low number of birds no remarkable differences appeared when comparing migratory activity amongst observation sites.

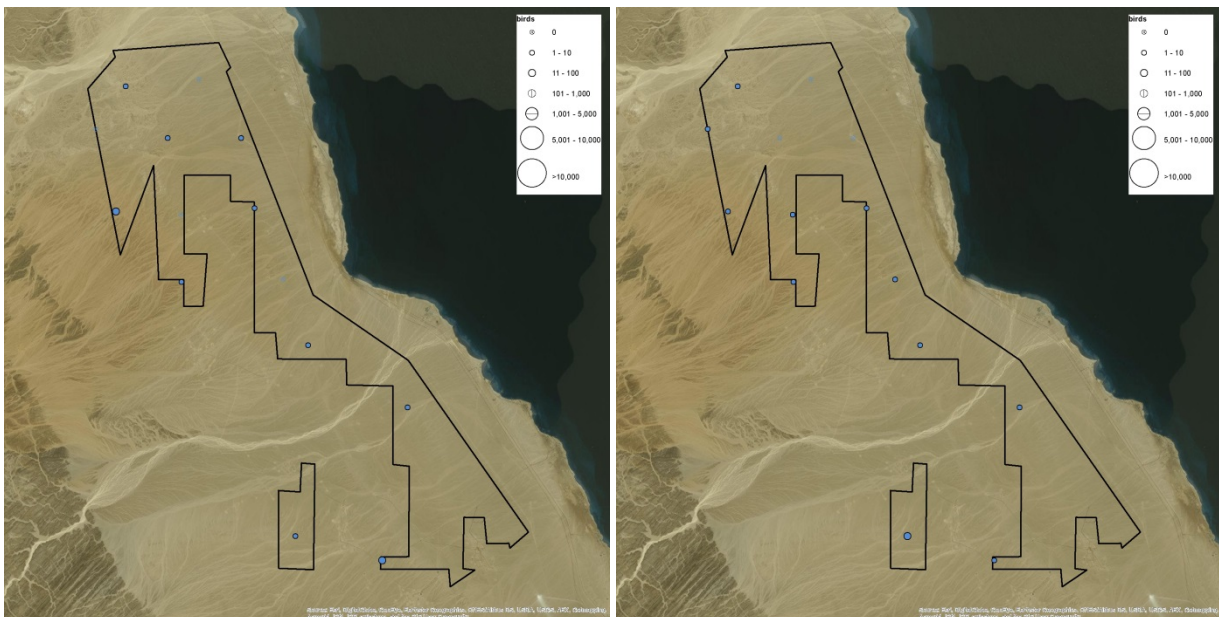

Number of birds (in abundance classes) registered within the study area in **spring 2016** (left) and **2017** (right)

Short-toed Snake Eagle

Short-toed Snake Eagle

Circaetus gallicus

IUCN-Red List: Least Concern

Flyway Population (individuals): 8,783

	autumn 2016		spring 2016		spring 2017	
	birds	records	birds	records	birds	records
study area	1	1	100	71	472	302
overall	1	1	101	72	472	302

1. Seasonal Migration Pattern (Phenology)

This species was recorded only once in autumn.

Spring migration of Short-toed Snake Eagle in 2017 lasted from end of February to mid of May. Most birds were registered within two waves between end of February and end of March as well as beginning of April and mid / end of April.

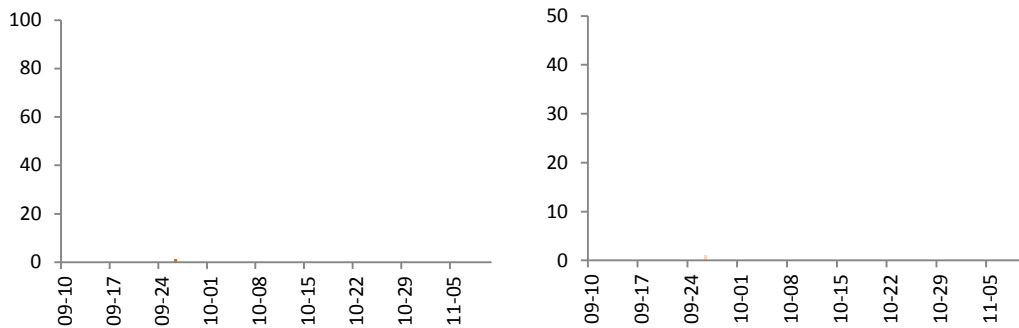

Number of birds (left) and records (right) registered in the study area in **autumn 2016**

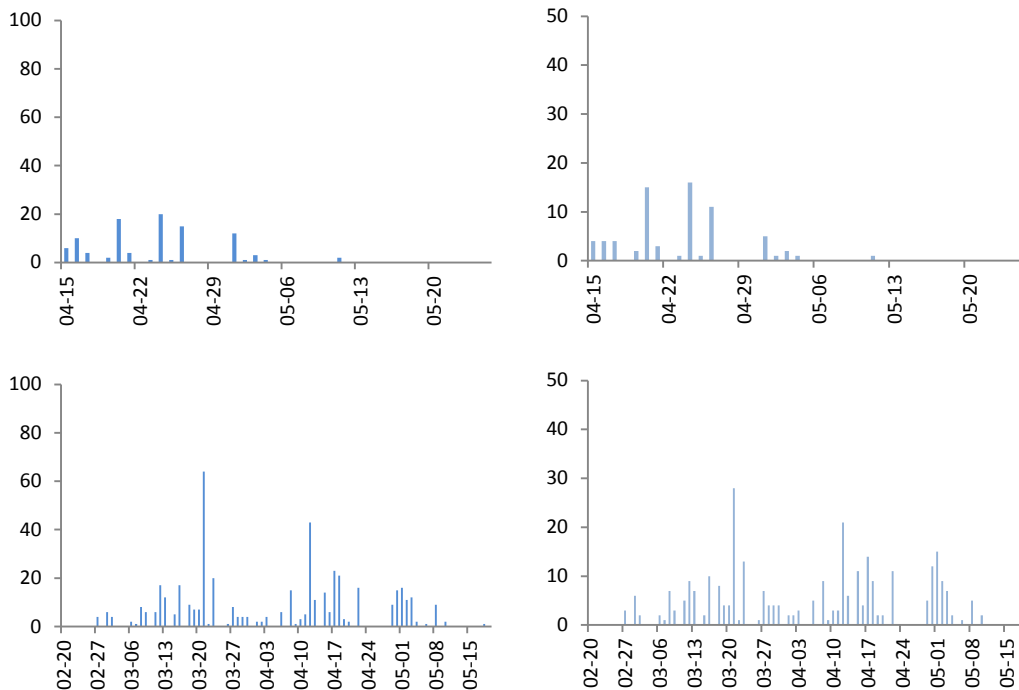

Number of birds (left) and records (right) registered in the study area in **spring 2016** (above) and **2017** (below)

Short-toed Snake Eagle

2. Flight altitude

The only observed bird in autumn 2016 was registered at risk height, i.e. > 30 to 120 m.

In spring most birds were recorded above 120 m and thus above risk height. In spring 2017 a significant share of the flyway population (1.5 %) was observed at least temporarily at risk height. In spring 2016 0.4 % of the flyway population were recorded at least temporarily at risk height.

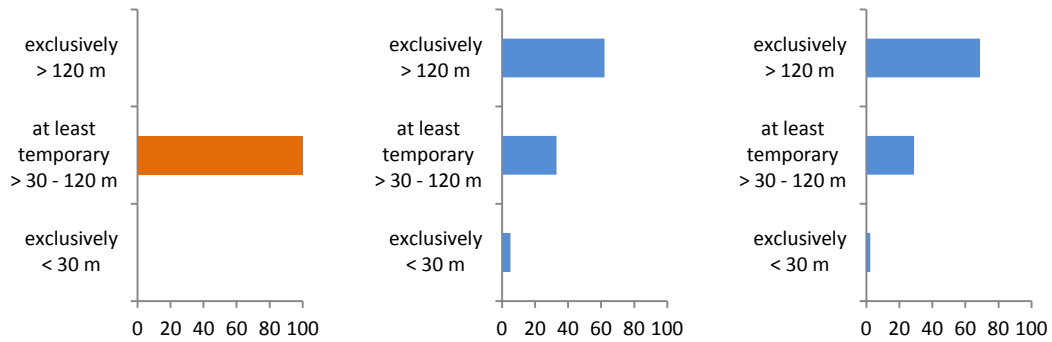

Relative abundance (percentage) of birds recorded at different altitude classes in the study area in **autumn 2016** (n=1; left), **spring 2016** (n=100; middle) and **2017** (n=472; right)



Short-toed Snake Eagle

Short-toed Snake Eagle

3. Daily Migration Pattern

The species was recorded only once in autumn.

During spring the migratory activity increased from the morning onwards and decreased again after about 6 hours after sunrise.

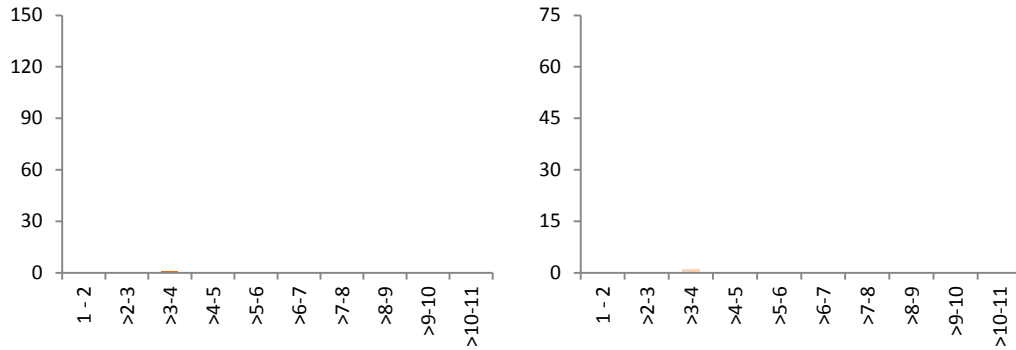

Number of birds (left) and records (right) registered in the study area at different hours after sunrise in **autumn 2016** - no observations were conducted in early morning and evening

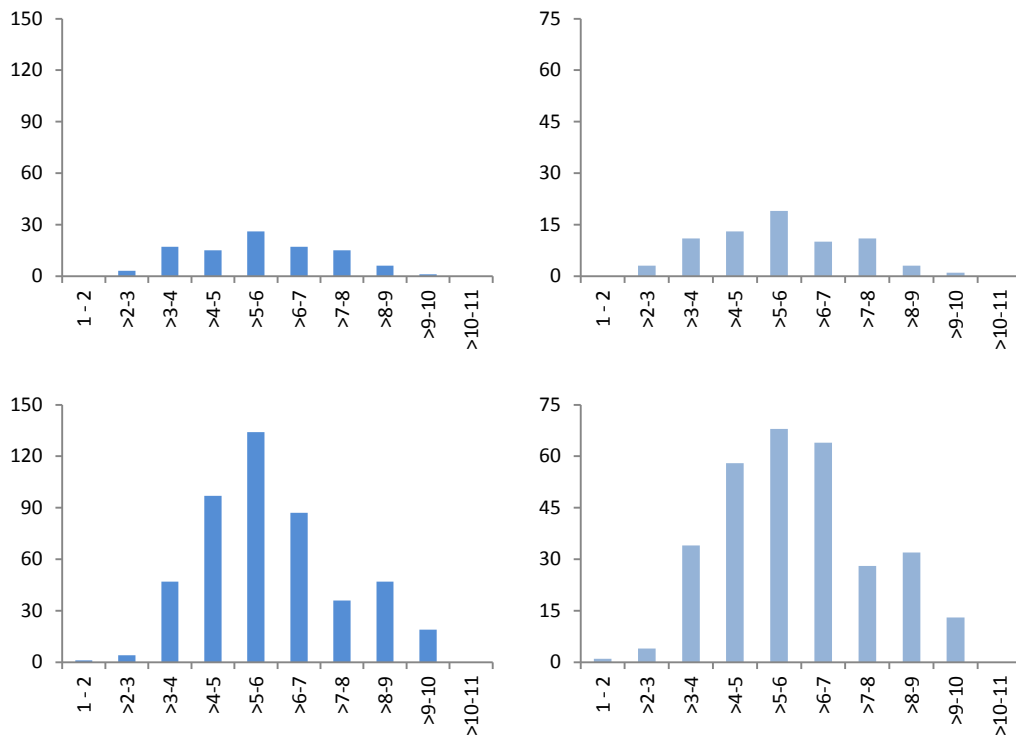

Number of birds (left) and records (right) registered in the study area at different hours after sunrise in **spring 2016** (above) and **2017** (below) - no observations were conducted in early morning and evening

Short-toed Snake Eagle

4. Spatial Migration Pattern

No remarkable differences appeared when comparing migratory activity amongst observation sites.



Number of birds (in abundance classes) registered within the study area in **autumn 2016** (above), **spring 2016** (below left) and **2017** (below right)

Marsh Harrier

Marsh Harrier *Circus aeruginosus*

IUCN-Red List: Least Concern

Flyway Population (individuals): 126,777

	autumn 2016		spring 2016		spring 2017	
	birds	records	birds	records	birds	records
study area	31	27	27	22	36	30
overall	33	29	27	22	36	30

1. Seasonal Migration Pattern (Phenology)

This species was recorded during various times within the study periods in autumn and spring. In autumn most birds were recorded until mid of October and in spring 2017 from end of March onwards. In spring 2016 numbers peaked during end of April.

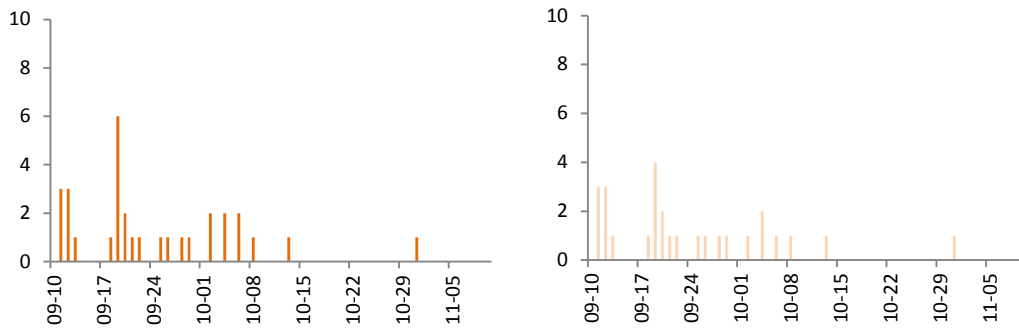

Number of birds (left) and records (right) registered in the study area in **autumn 2016**

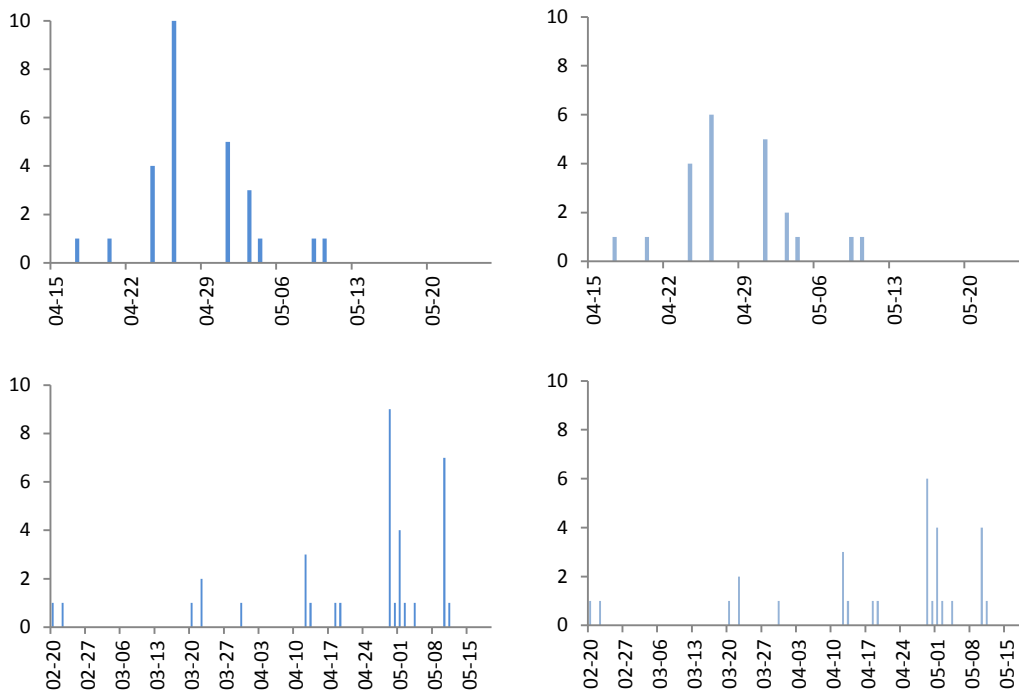

Number of birds (left) and records (right) registered in the study area in **spring 2016** (above) and **2017** (below)

Marsh Harrier

2. Flight altitude

The (few) recorded birds did not prefer a certain height class. In autumn and spring 2016 most Marsh Harriers were recorded at risk height (i.e. > 30 to 120 m) or above risk height and in spring 2017 at risk height and below risk height. However, the informative value of these results is limited due to the low number of birds / records.

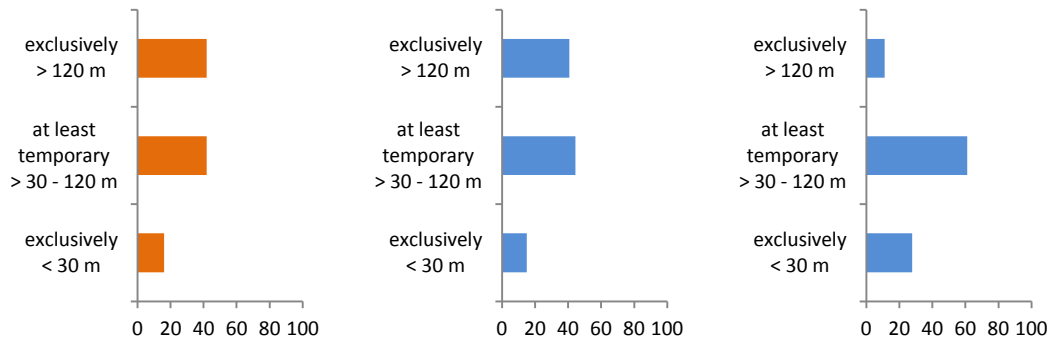

Relative abundance (percentage) of birds recorded at different altitude classes in the study area in **autumn 2016** (n=31; left), **spring 2016** (n=27; middle) and **2017** (n=36; right)

Marsh Harrier

3. Daily Migration Pattern

Marsh Harriers were observed during various times of the day in autumn and spring. Migratory activity during spring increased during the morning and then decreased again.

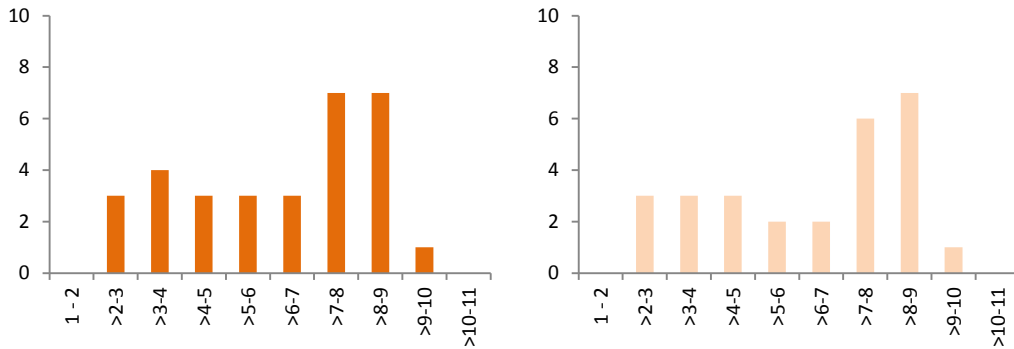

Number of birds (left) and records (right) registered in the study area at different hours after sunrise in **autumn 2016** - no observations were conducted in early morning and evening

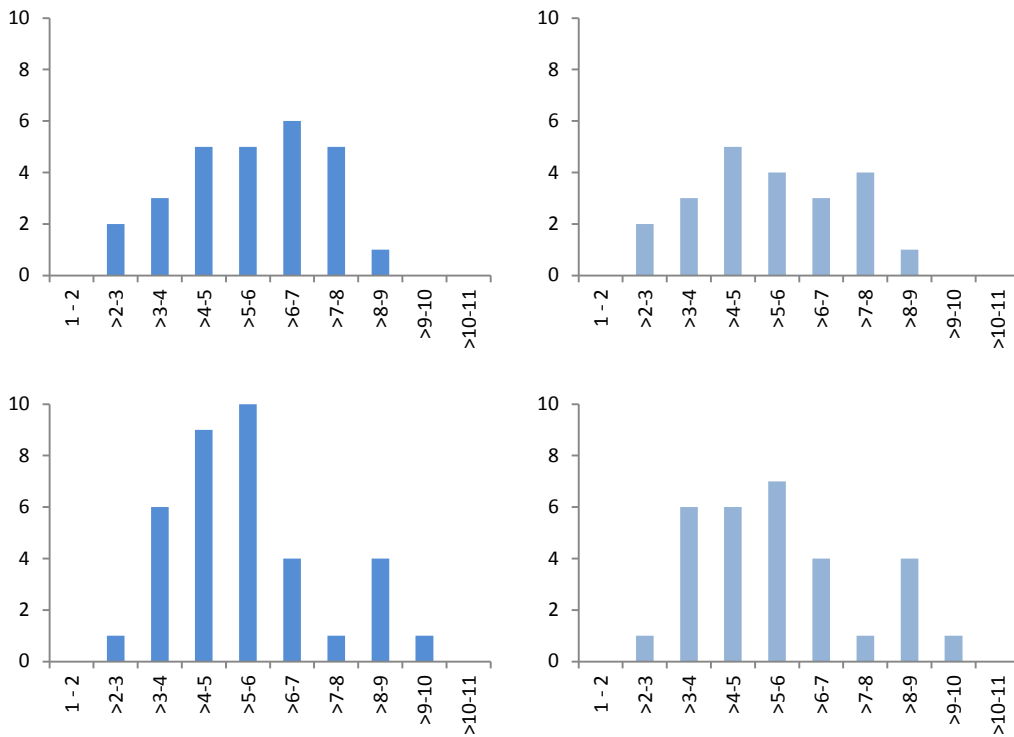

Number of birds (left) and records (right) registered in the study area at different hours after sunrise in **spring 2016** (above) and **2017** (below) - no observations were conducted in early morning and evening

Marsh Harrier

4. Spatial Migration Pattern

Due to the low number of birds no remarkable differences appeared when comparing migratory activity in the study area.



Number of birds (in abundance classes) registered within the study area in **autumn 2016** (above), **spring 2016** (below left) and **2017** (below right)

Pallid Harrier

Pallid Harrier
Circus macrourus

IUCN-Red List: Near Threatened

Flyway Population (individuals): 1,505

	autumn 2016		spring 2016		spring 2017	
	birds	records	birds	records	birds	records
study area	11	11	4	4	10	10
overall	11	11	4	4	10	10

1. Seasonal Migration Pattern (Phenology)

During autumn 2016 11 Pallid Harriers occurred in the study area from begin of September onwards. Most of those birds migrated during October.

In spring 2016 all four individuals were recorded in the beginning of May. During spring 2017 the ten individuals were recorded between end of March and mid of May, whereof most birds were recorded up to mid of April.

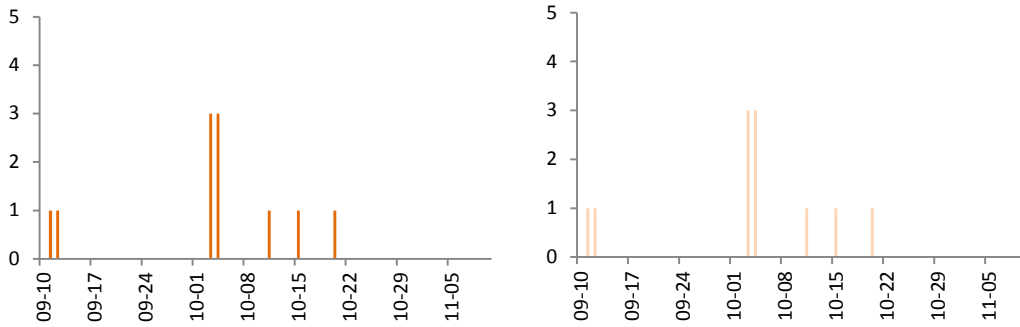

Number of birds (left) and records (right) registered in the study area in **autumn 2016**

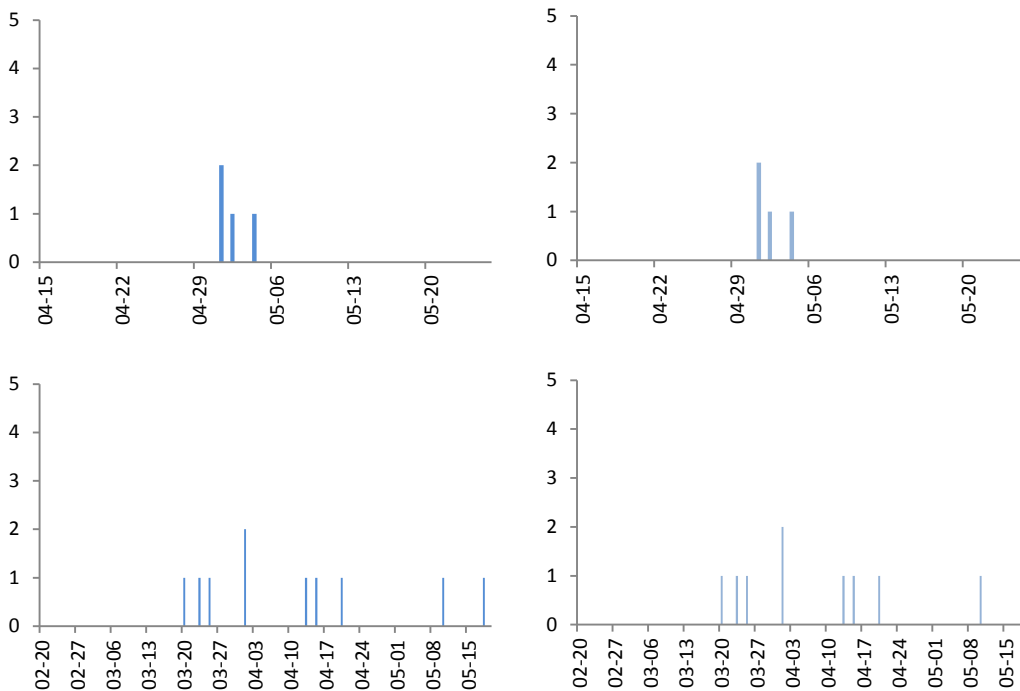

Number of birds (left) and records (right) registered in the study area in **spring 2016** (above) and **2017** (below)

Pallid Harrier

2. Flight altitude

The (few) recorded birds did not prefer a certain height class. In autumn 2016 most bird migrated below the risk height (i.e. > 30 to 120 m), in spring 2016 above risk height and in spring 2017 at risk height. However, the informative value of these results is limited due to the low number of birds / records.

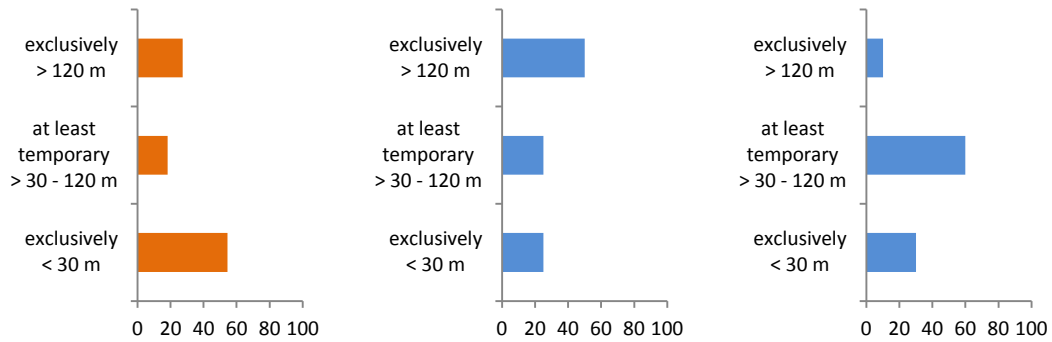

Relative abundance (percentage) of birds recorded at different altitude classes in the study area in **autumn 2016** (n=11; left), **spring 2016** (n=4; middle) and **2017** (n=10; right)

Pallid Harrier

3. Daily Migration Pattern

Individuals of the Pallid Harrier were observed during various times of the day in autumn and spring.

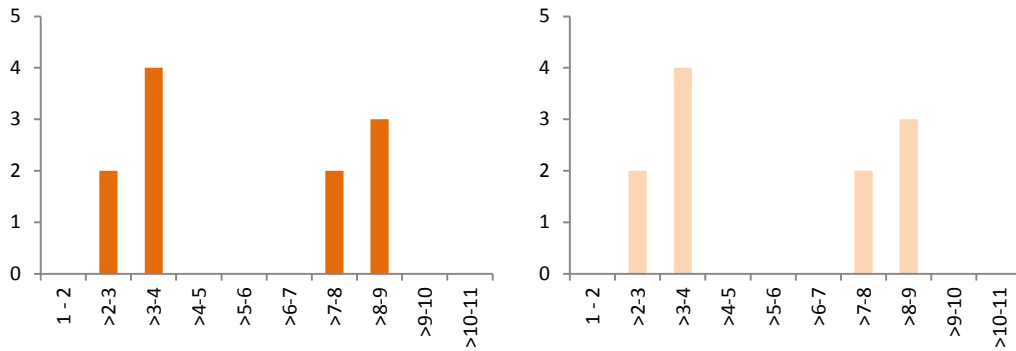

Number of birds (left) and records (right) registered in the study area at different hours after sunrise in **autumn 2016** - no observations were conducted in early morning and evening

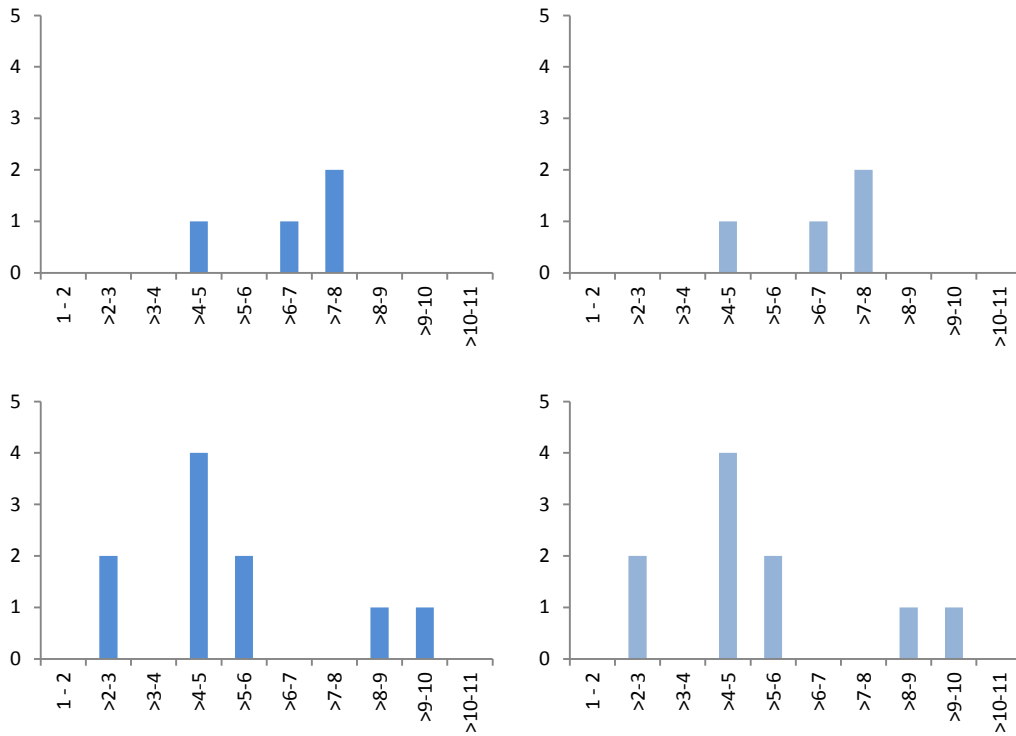

Number of birds (left) and records (right) registered in the study area at different hours after sunrise in **spring 2016** (above) and **2017** (below) - no observations were conducted in early morning and evening

Pallid Harrier

4. Spatial Migration Pattern

Due to the low number of birds no remarkable differences appeared when comparing migratory activity in the study area.



Number of birds (in abundance classes) registered within the study area in **autumn 2016** (above), **spring 2016** (below left) and **2017** (below right)

Montagu's Harrier

Montagu's Harrier

Circus pygargus

IUCN-Red List: Least Concern

Flyway Population (individuals): 50,500

	autumn 2016		spring 2016		spring 2017	
	birds	records	birds	records	birds	records
study area	11	10	4	4	42	32
overall	11	10	4	4	42	32

1. Seasonal Migration Pattern (Phenology)

In autumn and spring single Montagu's Harriers were observed during various times of the study period.

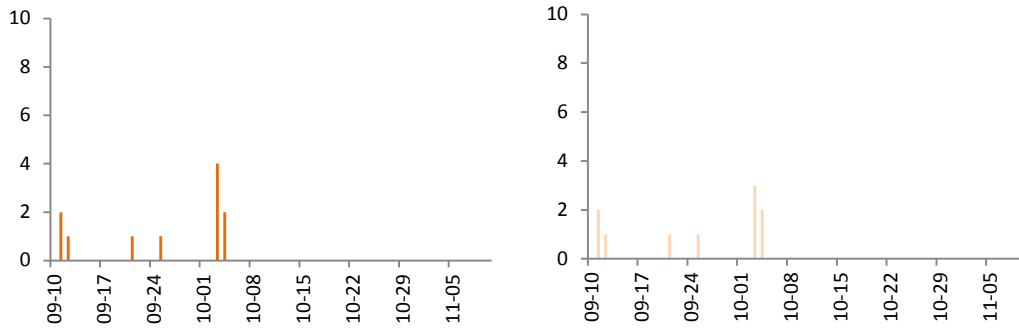

Number of birds (left) and records (right) registered in the study area in **autumn 2016**

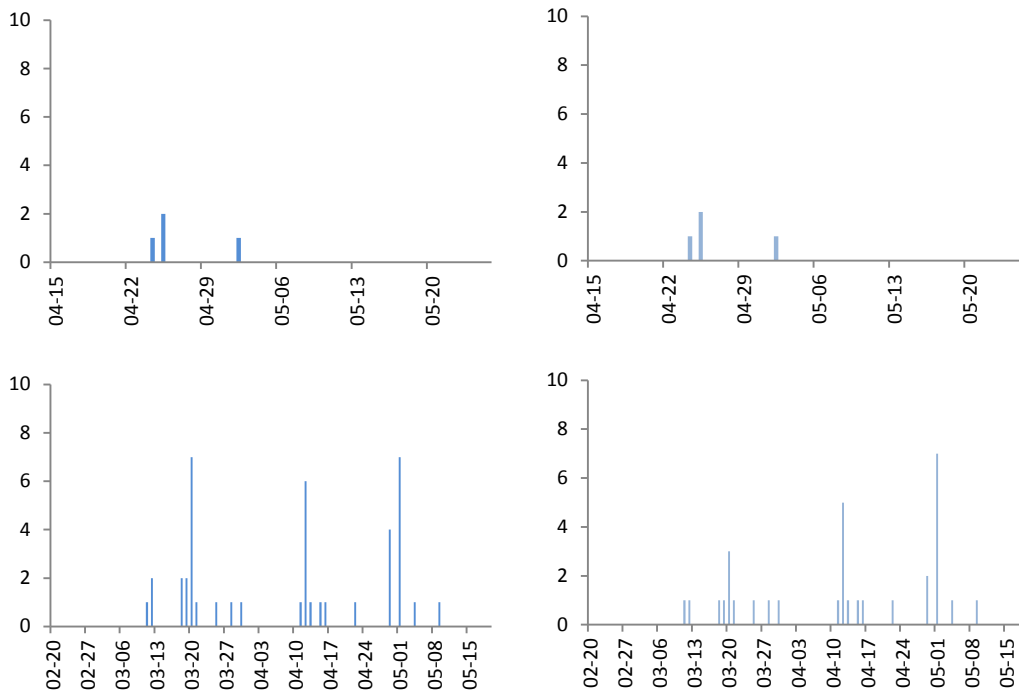

Number of birds (left) and records (right) registered in the study area in **spring 2016** (above) and **2017** (below)

Montagu's Harrier

2. Flight altitude

The (few) recorded birds did not prefer a certain height class. In autumn 2016 most birds were recorded below the risk height (i.e. > 30 to 120 m) and in spring 2016 and 2017 the number of bird distributed over the different height classes. However, the informative value of these results is limited due to the low number of birds / records.

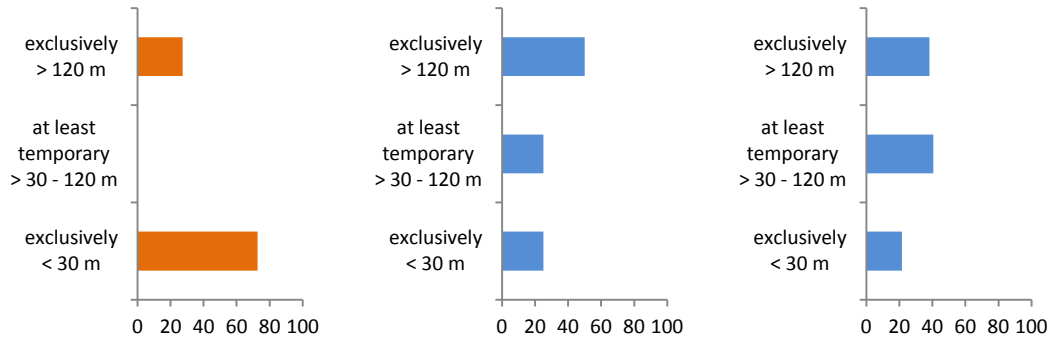

Relative abundance (percentage) of birds recorded at different altitude classes in the study area in **autumn 2016** (n=11; left), **spring 2016** (n=4; middle) and **2017** (n=42; right)

Montagu's Harrier

3. Daily Migration Pattern

Migrating individuals occurred during various times of the day in autumn and spring. By trend more birds were recorded during the morning hours.

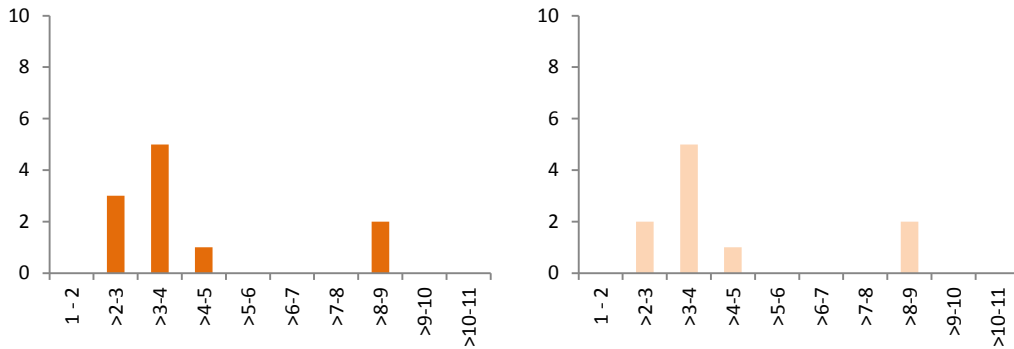

Number of birds (left) and records (right) registered in the study area at different hours after sunrise in **autumn 2016** - no observations were conducted in early morning and evening

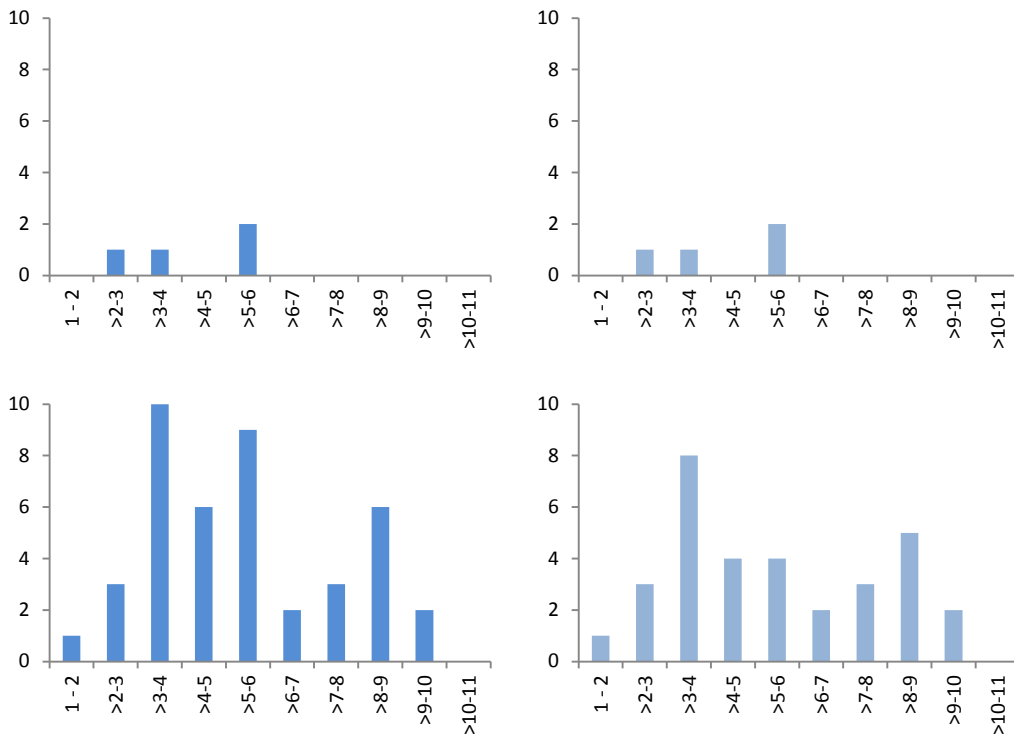

Number of birds (left) and records (right) registered in the study area at different hours after sunrise in **spring 2016** (above) and **2017** (below) - no observations were conducted in early morning and evening

Montagu's Harrier

4. Spatial Migration Pattern

Due to the low number of birds no remarkable differences appeared when comparing migratory activity in the study area.



Number of birds (in abundance classes) registered within the study area in **autumn 2016** (above), **spring 2016** (below left) and **2017** (below right)

Levant Sparrowhawk

Levant Sparrowhawk

Accipiter brevipes

IUCN-Red List: Least Concern

Flyway Population (individuals): 75,000

	autumn 2016		spring 2016		spring 2017	
	birds	records	birds	records	birds	records
study area	20	4	413	18	822	14
overall	20	4	413	18	822	14

1. Seasonal Migration Pattern (Phenology)

In autumn single migrating individuals were registered in the beginning of October.

In spring 2016 most birds were recorded end of April (61 % of all birds on April 24th). During spring 2017 once a flock of 800 individuals (97 % of all birds) was recorded on April 22nd.

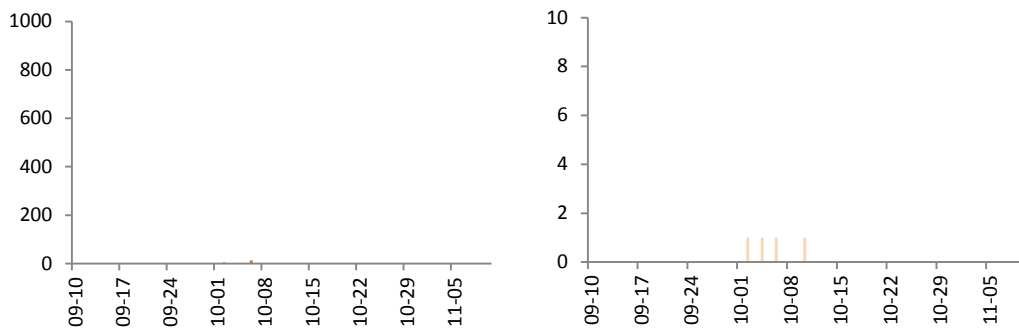

Number of birds (left) and records (right) registered in the study area in **autumn 2016**

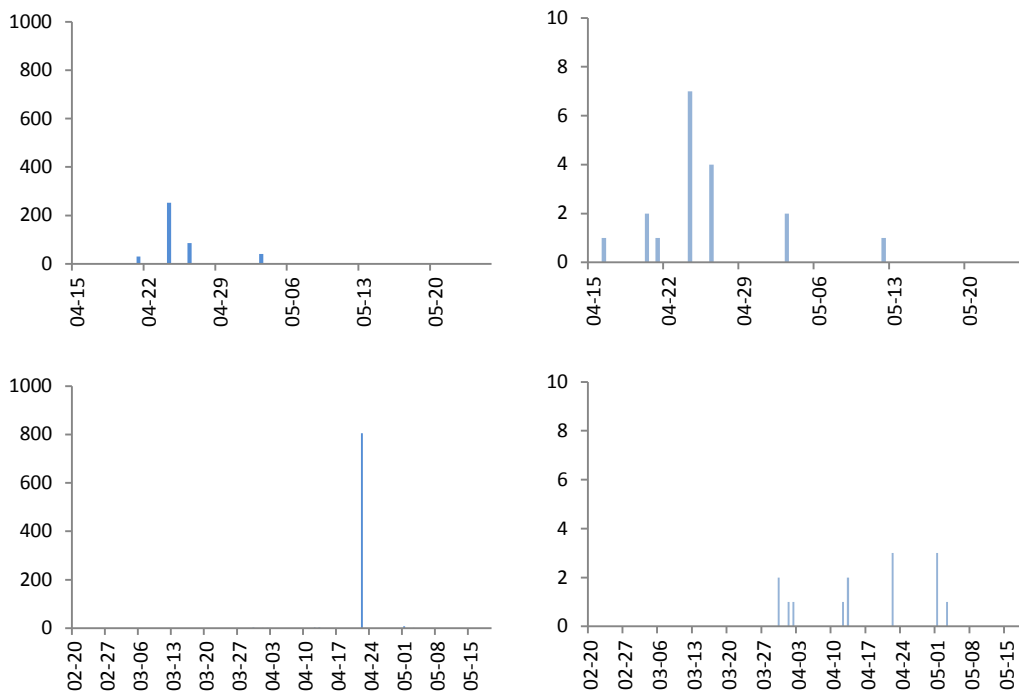

Number of birds (left) and records (right) registered in the study area in **spring 2016** (above) and **2017** (below)

Levant Sparrowhawk

2. Flight altitude

In autumn and spring all birds were recorded at altitudes above 120 m (i.e. above risk height > 30 to 120 m).

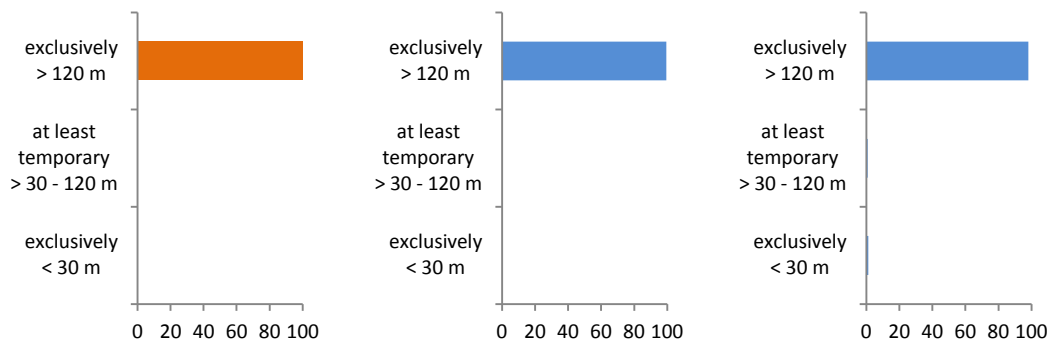

Relative abundance (percentage) of birds recorded at different altitude classes in the study area in **autumn 2016** (n=20; left), **spring 2016** (n=413; middle) and **2017** (n=822; right)

Levant Sparrowhawk

3. Daily Migration Pattern

In autumn and spring Levant Sparrowhawks appeared during various periods of the day.

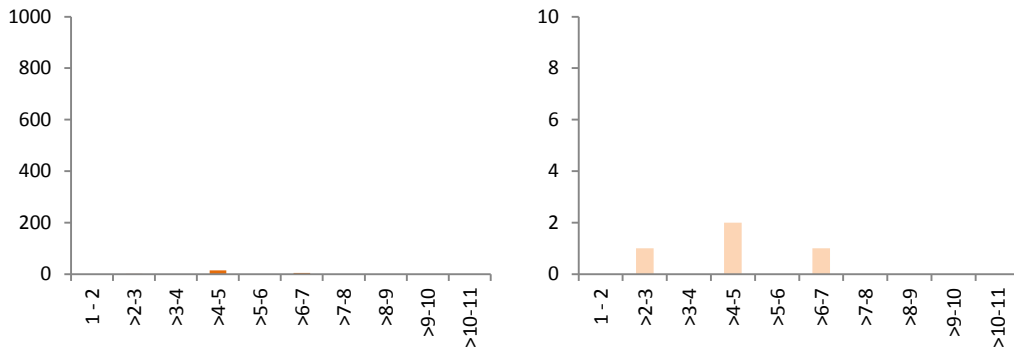

Number of birds (left) and records (right) registered in the study area at different hours after sunrise in **autumn 2016** - no observations were conducted in early morning and evening

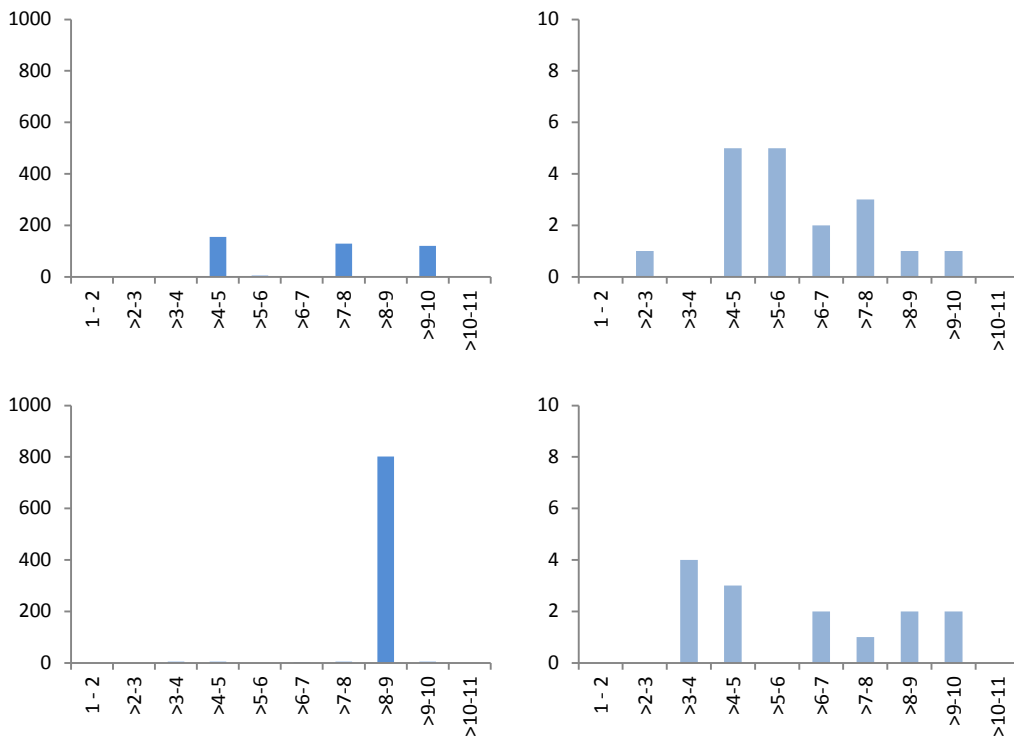

Number of birds (left) and records (right) registered in the study area at different hours after sunrise in **spring 2016** (above) and **2017** (below) - no observations were conducted in early morning and evening

Levant Sparrowhawk

4. Spatial Migration Pattern

Due to the low number of birds no remarkable differences appeared when comparing migratory activity in the study area during autumn 2016.

During spring differences occurred, which were caused by single flocks at certain observation sites.



Number of birds (in abundance classes) registered within the study area in **autumn 2016** (above), **spring 2016** (below left) and **2017** (below right)

Eurasian Sparrowhawk

Eurasian Sparrowhawk

Accipiter nisus

IUCN-Red List: Least Concern

Flyway Population (individuals): unknown

	autumn 2016		spring 2016		spring 2017	
	birds	records	birds	records	birds	records
study area	2	2	45	33	14	12
overall	2	2	46	34	14	12

Remark: The flyway population of Eurasian Sparrowhawk is unknown. The species is distributed within the Holarctic and is quite common with, for instance, a population of more than 800,000 birds in Europe (according to Birdlife International). Many birds of the population do not migrate as far as Egypt or Africa, but stay in Europe. To conclude, even though the flyway population is unknown, a rather large population can be assumed and, thus, the registered number of birds does not represent a significant portion of this population.

1. Seasonal Migration Pattern (Phenology)

In autumn two single migrating birds were recorded in October (which corresponds with the peak migration period in Europe). In spring 2016 and 2017 the species was recorded occasionally in April and May.

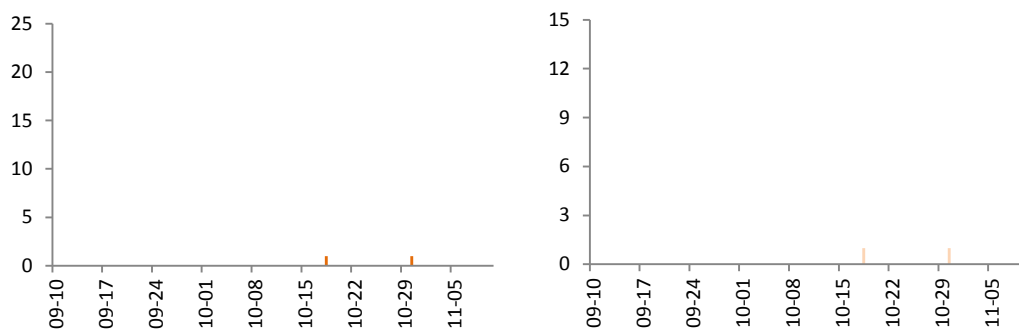

Number of birds (left) and records (right) registered in the study area in **autumn 2016**

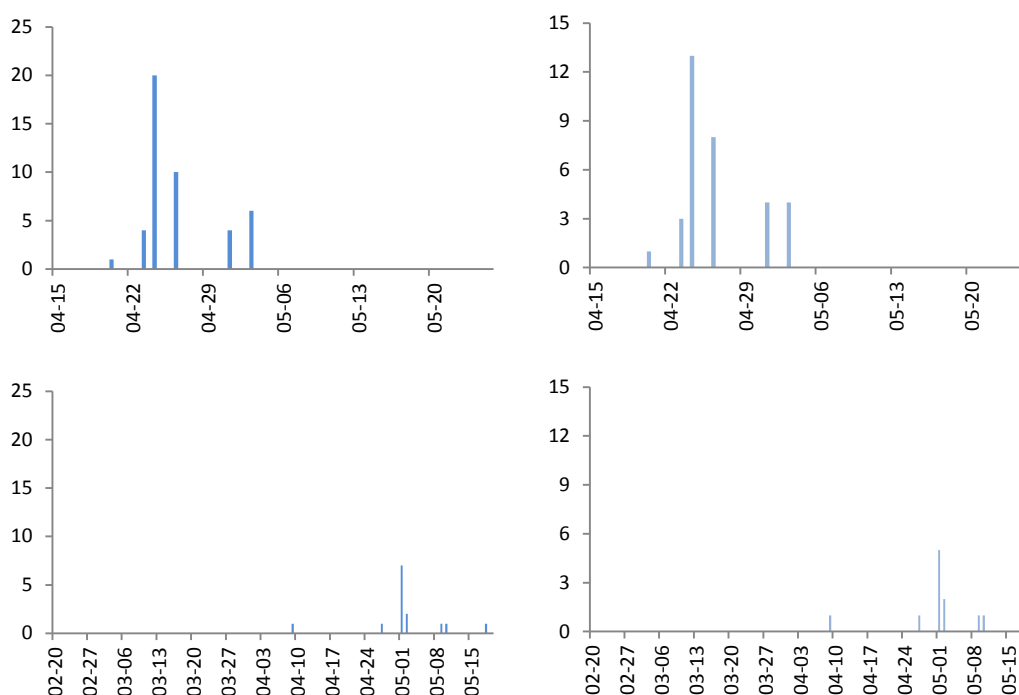

Number of birds (left) and records (right) registered in the study area in **spring 2016** (above) and **2017** (below)

Eurasian Sparrowhawk

2. Flight altitude

The (few) recorded birds did not prefer a certain height class. In autumn 2016 one bird was recorded within and below the risk height each (i.e. > 30 to 120 m). In spring 2016 most birds migrated above risk height and in spring 2017 within risk height. However, the informative value of these results is limited due to the low number of birds / records.

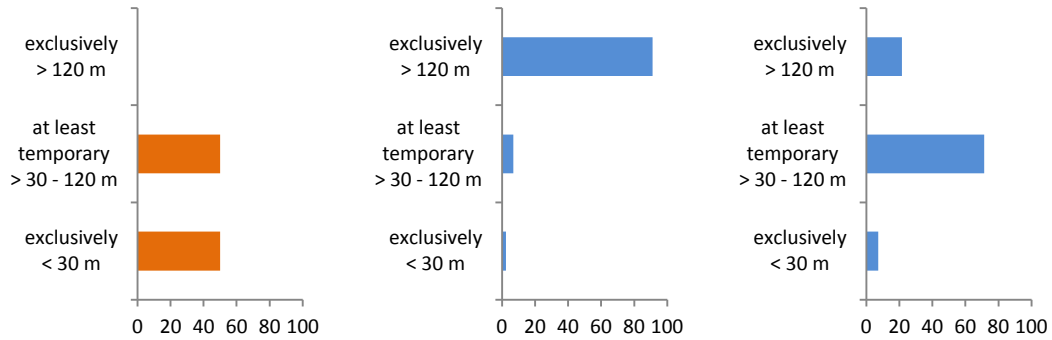

Relative abundance (percentage) of birds recorded at different altitude classes in the study area in **autumn 2016** (n=2; left), **spring 2016** (n=45; middle) and **2017** (n=14; right)

Eurasian Sparrowhawk

3. Daily Migration Pattern

Migrating Eurasian Sparrowhawks appeared during various times of the day in the study area in autumn and spring. In spring 2016 migratory activity seemed to increase during the morning and decrease afterwards again. However, the low number of birds / records has to be considered when interpreting the results.

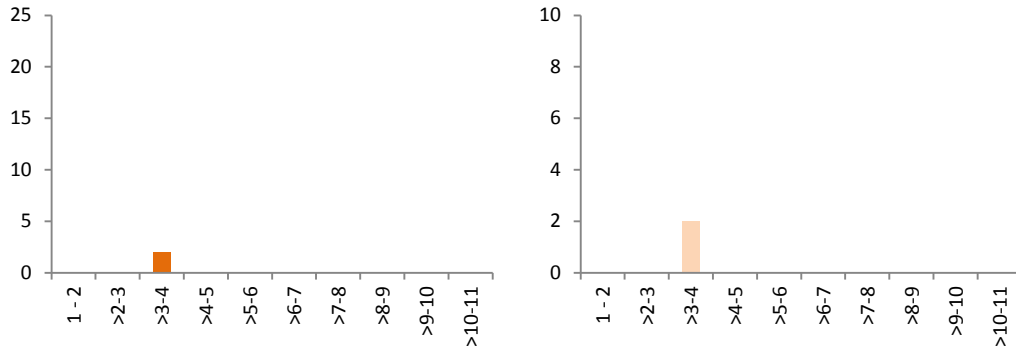

Number of birds (left) and records (right) registered in the study area at different hours after sunrise in **autumn 2016** - no observations were conducted in early morning and evening

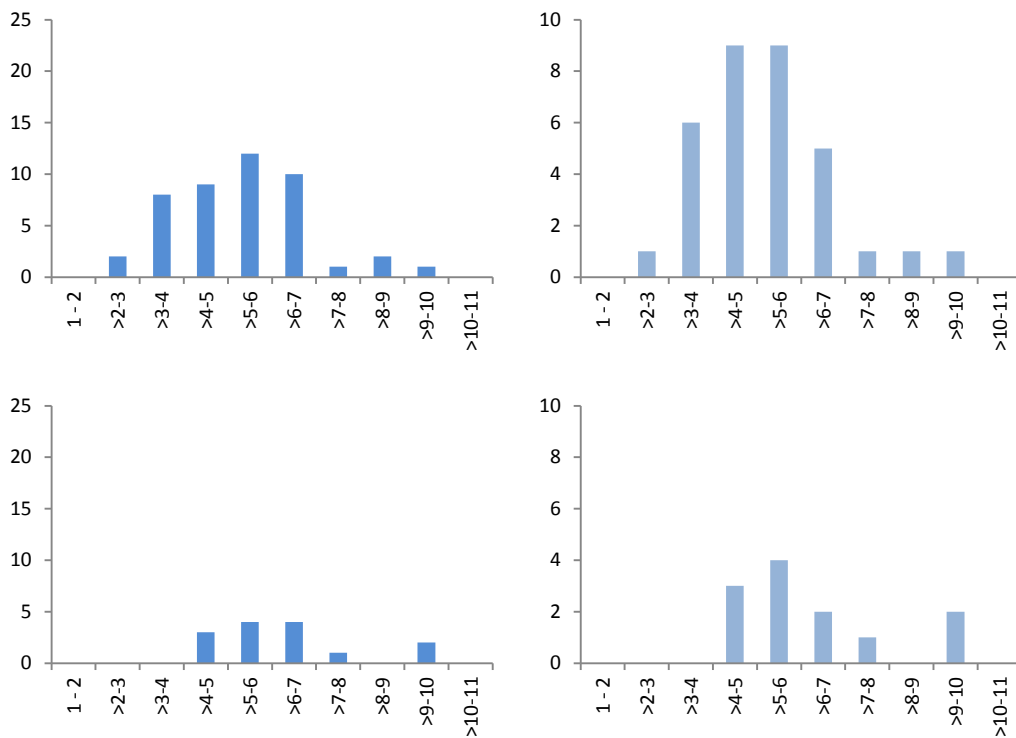

Number of birds (left) and records (right) registered in the study area at different hours after sunrise in **spring 2016** (above) and **2017** (below) - no observations were conducted in early morning and evening

Eurasian Sparrowhawk

4. Spatial Migration Pattern

Due to the low number of birds no remarkable differences appeared when comparing migratory activity in the study area.



Number of birds (in abundance classes) registered within the study area in **autumn 2016** (above), **spring 2016** (below left) and **2017** (below right)

Steppe Buzzard

Steppe Buzzard *Buteo buteo vulpinus*

IUCN-Red List: Least Concern

Flyway Population (individuals): 1,250,000

	autumn 2016		spring 2016		spring 2017	
	birds	records	birds	records	birds	records
study area	25	10	4,195	331	32,516	990
overall	25	10	6,077	341	32,529	993

1. Seasonal Migration Pattern (Phenology)

In autumn single migrating individuals were recorded from end of September onwards.

In spring 2017 the species was recorded almost throughout the whole study period. About 69 % of all Steppe Buzzards passed the study area on two days: April 12th and 13th. In spring 2016 67 % of all birds were registered on April 24th and 26th.

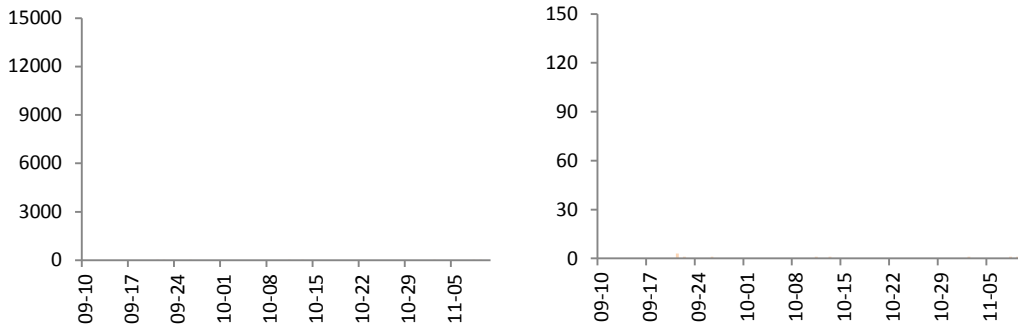

Number of birds (left) and records (right) registered in the study area in **autumn 2016**

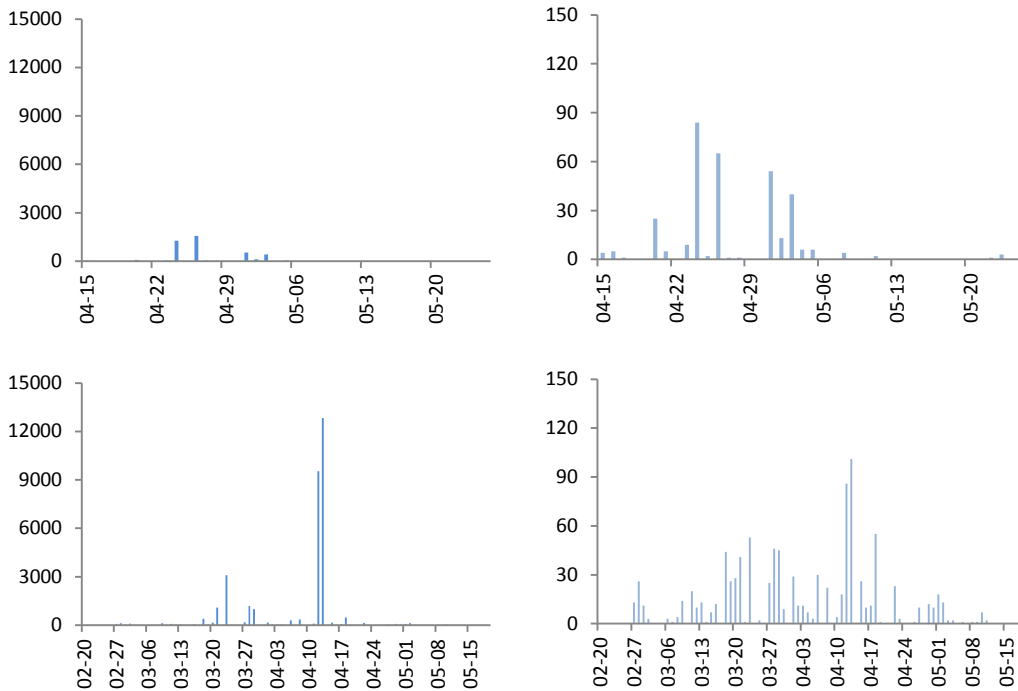

Number of birds (left) and records (right) registered in the study area in **spring 2016** (above) and **2017** (below)

Steppe Buzzard

2. Flight altitude

In autumn and spring most birds were recorded at altitudes above 120 m (i.e. above risk height > 30 to 120 m). The share of birds at risk height registered in spring 2017 represents 0.6 % of the flyway population.

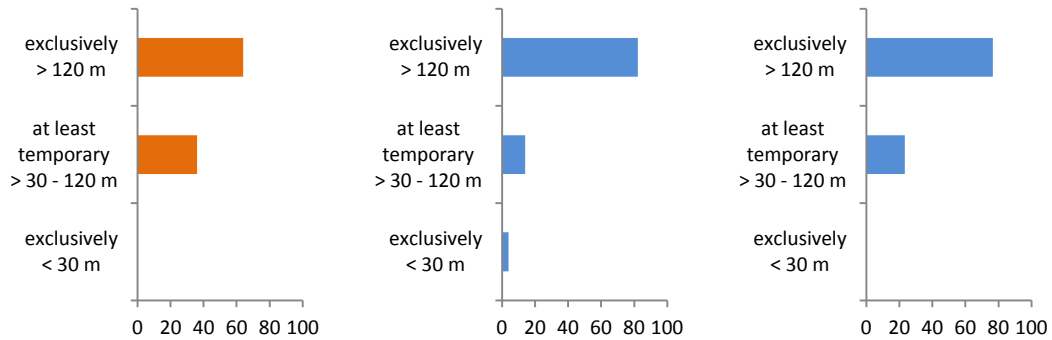

Relative abundance (percentage) of birds recorded at different altitude classes in the study area in **autumn 2016** (n=25; left), **spring 2016** (n=4,195; middle) and **2017** (n=32,516; right)



Steppe Buzzard

Steppe Buzzard

3. Daily Migration Pattern

Steppe Buzzards were registered during various times of the day in autumn. In spring the number of birds increased during the morning and then decreased again.

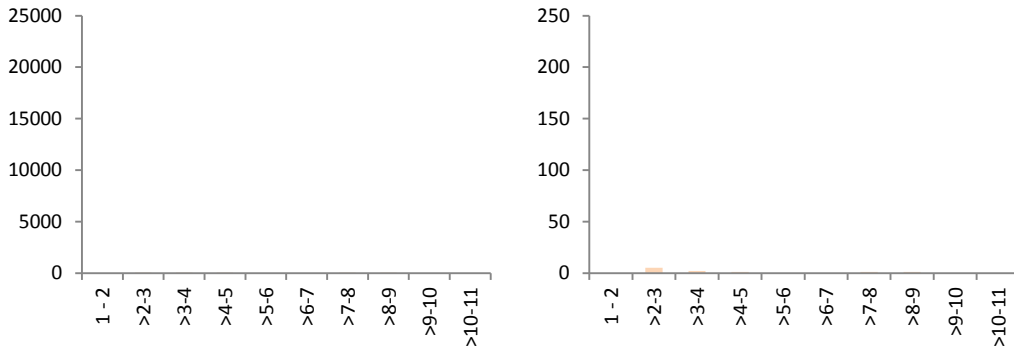

Number of birds (left) and records (right) registered in the study area at different hours after sunrise in **autumn 2016** - no observations were conducted in early morning and evening

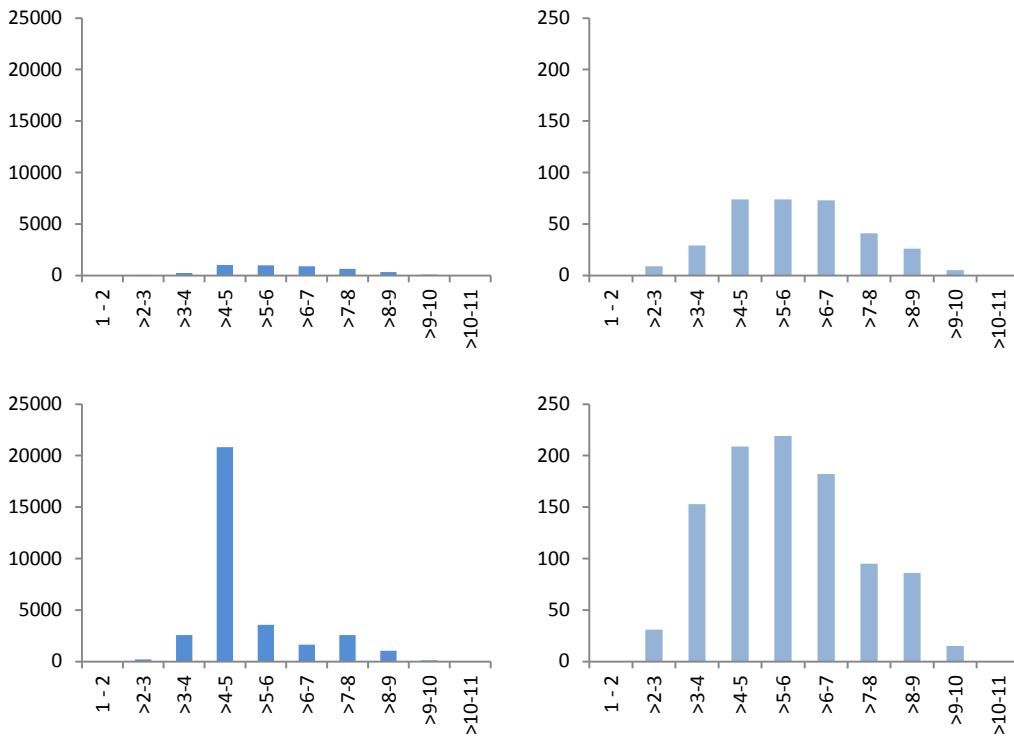

Number of birds (left) and records (right) registered in the study area at different hours after sunrise in **spring 2016** (above) and **2017** (below) - no observations were conducted in early morning and evening

Steppe Buzzard

4. Spatial Migration Pattern

Due to the relative low number of birds no remarkable differences appeared when comparing migratory activity in the study area in autumn.

In spring 2016 remarkable higher numbers of birds were recorded at observation sites 6F and 8F and in spring 2017 at observation sites 3 and 5. These differences were caused by few observation units with higher numbers of migrating Steppe Buzzards.



Number of birds (in abundance classes) registered within the study area in **autumn 2016** (above), **spring 2016** (below left) and **2017** (below right)

Long-legged Buzzard

Long-legged Buzzard

Buteo rufinus

IUCN-Red List: Least Concern

Flyway Population (individuals): 21,750

	autumn 2016		spring 2016		spring 2017	
	birds	records	birds	records	birds	records
study area	3	2	2	2	26	26
overall	3	2	2	2	26	26

1. Seasonal Migration Pattern (Phenology)

In autumn 2016 three and in spring 2016 two birds were recorded during two days within the study period each. In spring 2017 a total of 26 birds were recorded which did not concentrate within a certain period.

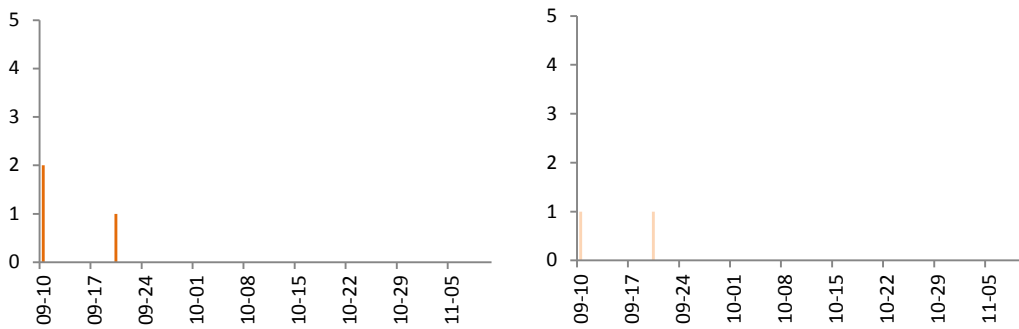

Number of birds (left) and records (right) registered in the study area in **autumn 2016**

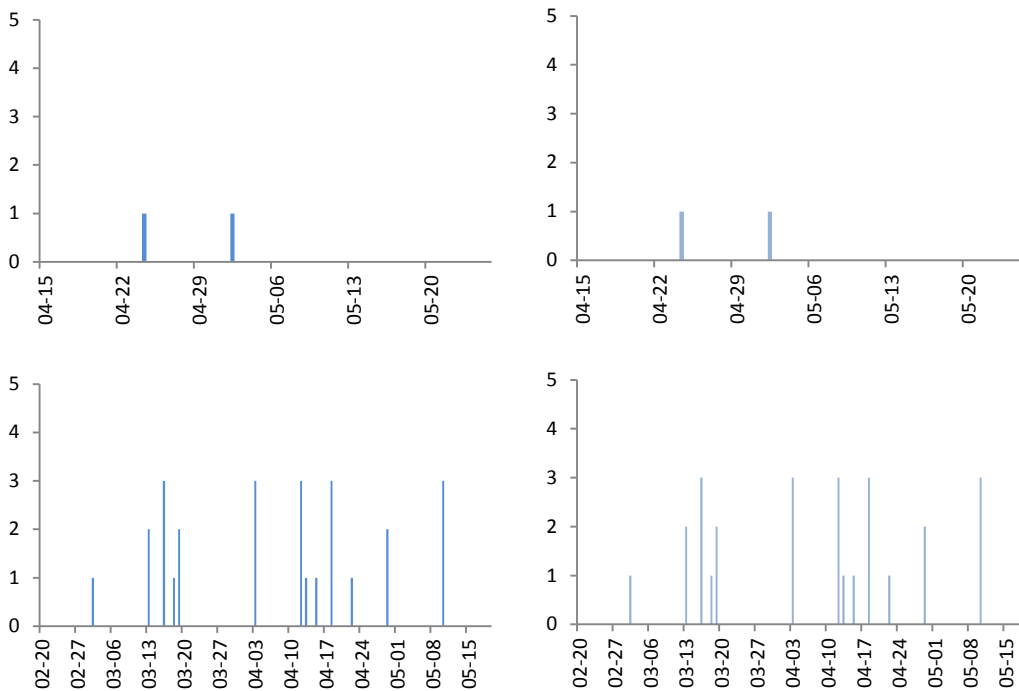

Number of birds (left) and records (right) registered in the study area in **spring 2016** (above) and **2017** (below)

Long-legged Buzzard

2. Flight altitude

Most birds were recorded above the risk height (i.e. > 30 to 120 m), in each of the three seasons. However, the informative value of this result is limited due to the low number of birds / records.

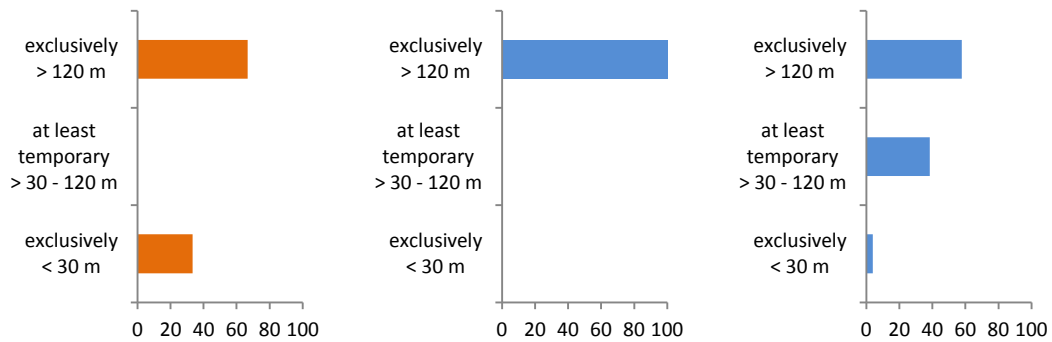

Relative abundance (percentage) of birds recorded at different altitude classes in the study area in **autumn 2016** (n=3; left), **spring 2016** (n=2; middle) and **2017** (n=26; right)

Long-legged Buzzard

3. Daily Migration Pattern

In spring Long-legged Buzzard appeared during various times of the day in the study area. For autumn and spring 2016 no pattern can be derived by the few observations. In spring 2017 migratory activity seemed to decrease from the morning to the afternoon. However, the low number of birds / records has to be considered when interpreting the results.

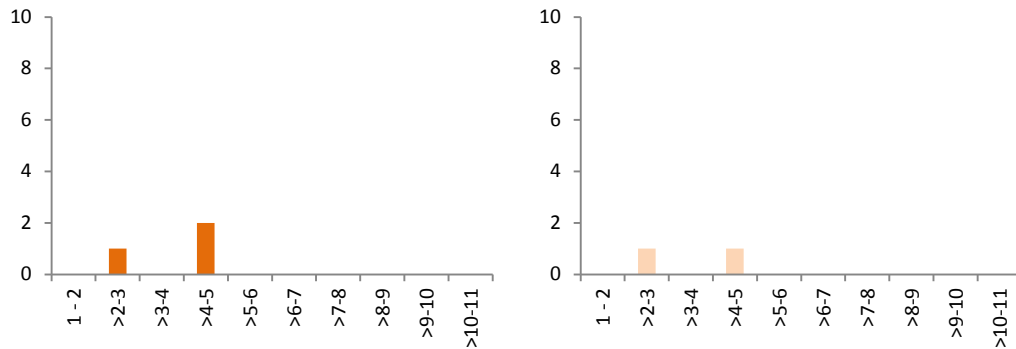

Number of birds (left) and records (right) registered in the study area at different hours after sunrise in autumn 2016 - no observations were conducted in early morning and evening

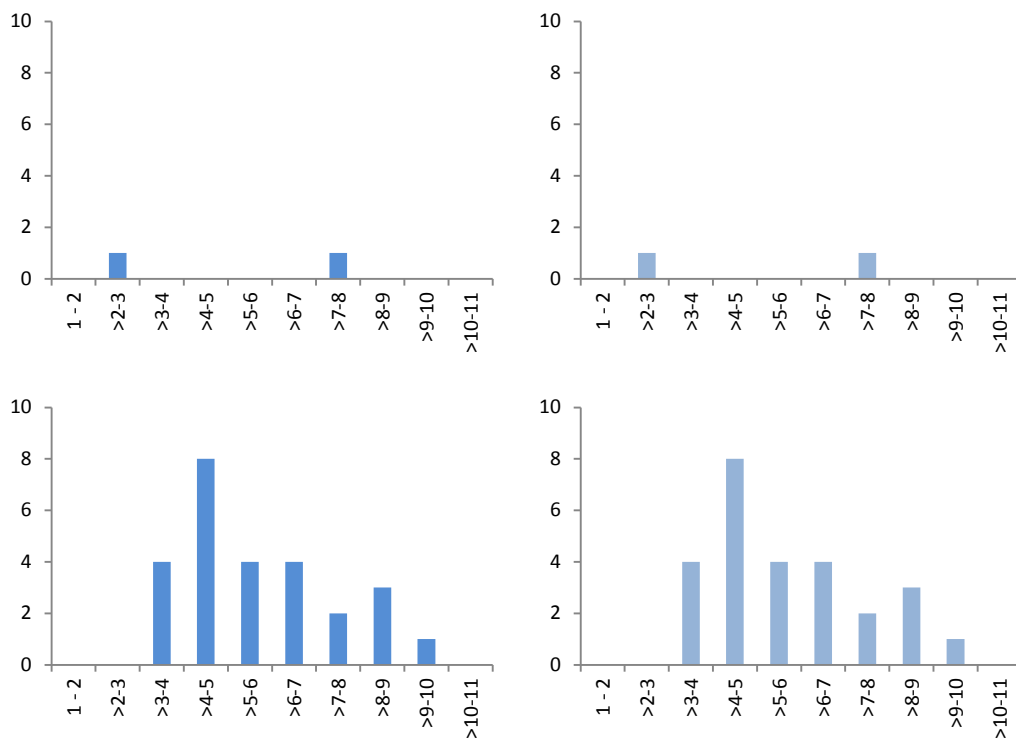

Number of birds (left) and records (right) registered in the study area at different hours after sunrise in spring 2016 (above) and 2017 (below) - no observations were conducted in early morning and evening

Long-legged Buzzard

4. Spatial Migration Pattern

Due to the low number of birds no remarkable differences appeared when comparing migratory activity in the study area.



Number of birds (in abundance classes) registered within the study area in **autumn 2016** (above), **spring 2016** (below left) and **2017** (below right)

Lesser Spotted Eagle

Lesser Spotted Eagle

Aquila pomarina

IUCN-Red List: Least Concern

Flyway Population (individuals): 85,000

	autumn 2016		spring 2016		spring 2017	
	birds	records	birds	records	birds	records
study area	0	0	156	64	72	42
overall	0	0	164	66	72	42

1. Seasonal Migration Pattern (Phenology)

This species was recorded in spring only. In spring 2016 most birds were recorded during end of April and beginning of May. In spring 2017 the majority of birds passed the study area in the second half of April.

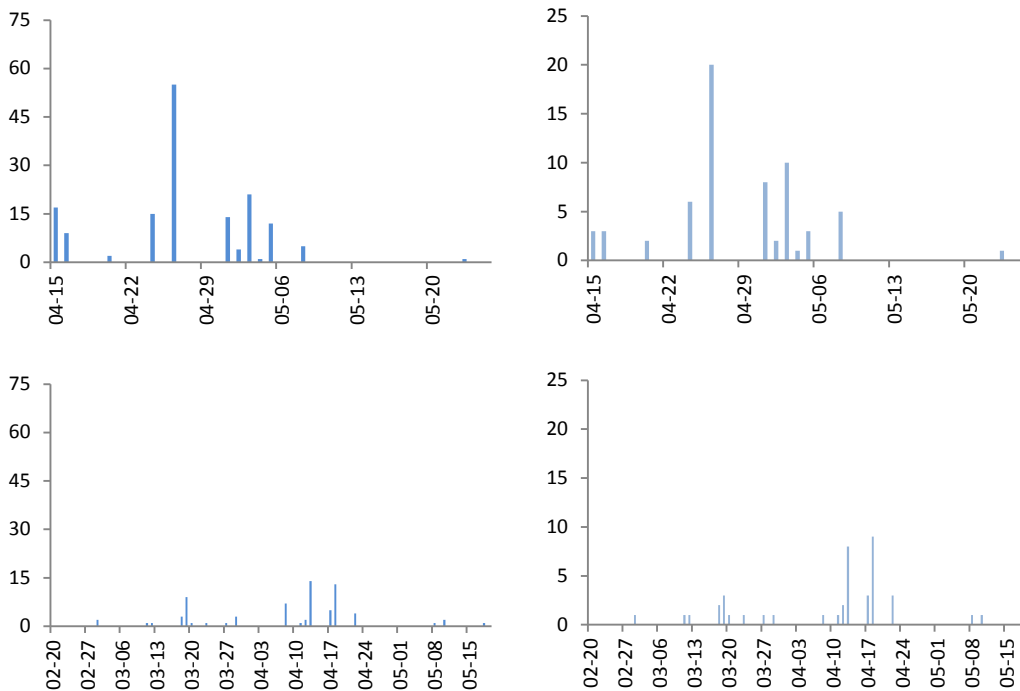

Number of birds (left) and records (right) registered in the study area in **spring 2016** (above) and **2017** (below)

2. Flight altitude

In spring 2016 and 2017 most birds were recorded at altitudes above 120 m and thus above risk height.

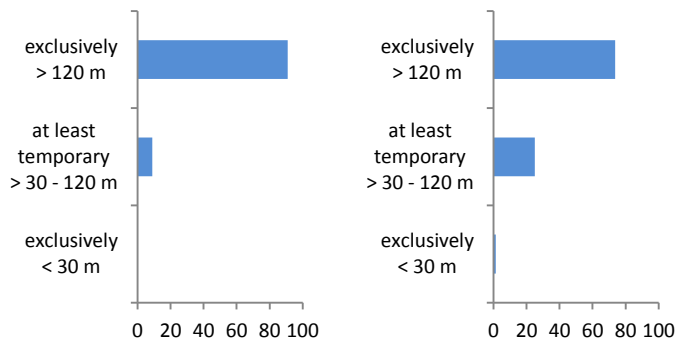

Relative abundance (percentage) of birds recorded at different altitude classes in the study area in **spring 2016** (n=156; left) and **2017** (n=72; right)

Lesser Spotted Eagle

3. Daily Migration Pattern

For spring 2016 and 2017 the data suggests a peak in the first 6 to 7 hours after sunrise followed by a decrease afterwards (in the midday / afternoon).

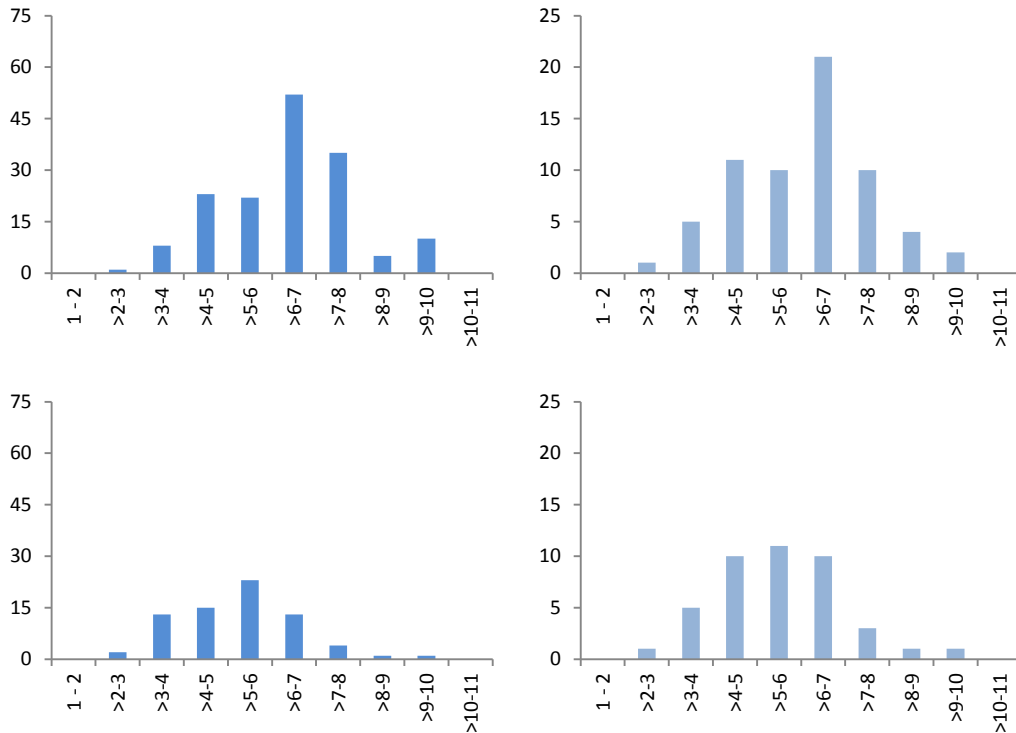

Number of birds (left) and records (right) registered at different hours after sunrise in the study area in **spring 2016** (above) and **2017** (below) - no observations were conducted in early morning and evening

4. Spatial Migration Pattern

No remarkable differences appeared when comparing migratory activity in the study area.

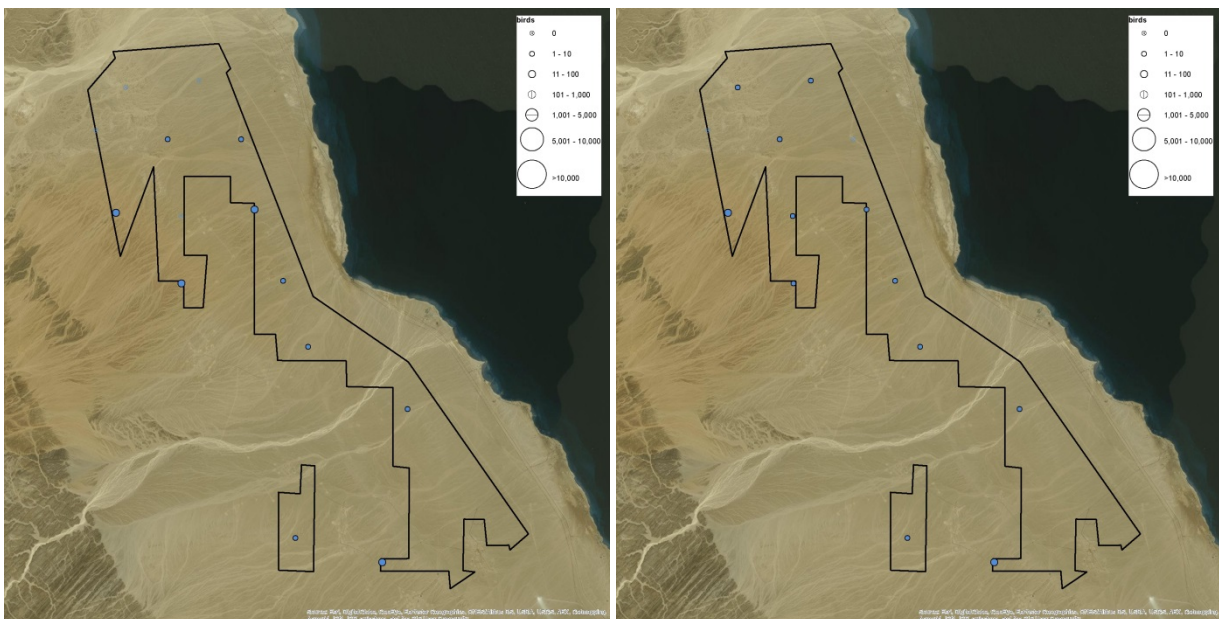

Number of birds (in abundance classes) registered within the study area in **spring 2016** (left) and **2017** (right)

Greater Spotted Eagle

Greater Spotted Eagle

Aquila clanga

IUCN-Red List: Vulnerable

Flyway Population (individuals): 2,180

	autumn 2016		spring 2016		spring 2017	
	birds	records	birds	records	birds	records
study area	0	0	4	4	10	6
overall	0	0	4	4	10	6

1. Seasonal Migration Pattern (Phenology)

During autumn 2016 no Greater Spotted Eagle was registered in the study area. In spring 2016 and 2017 single birds were recorded during various periods of the study period.

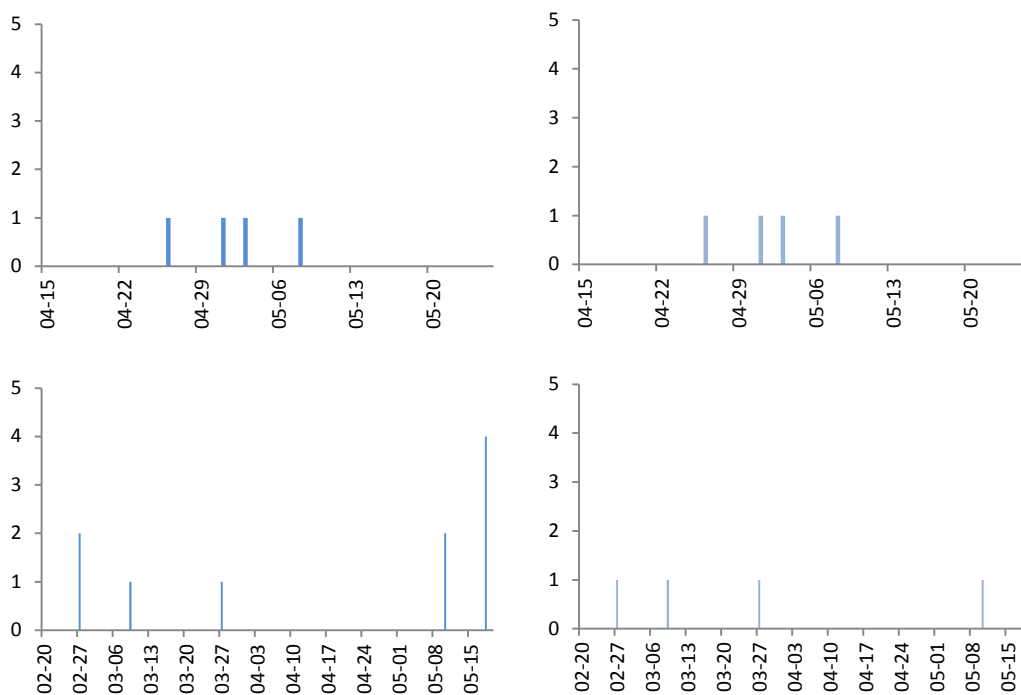

Number of birds (left) and records (right) registered in the study area in **spring 2016** (above) and **2017** (below)

2. Flight altitude

In spring 2016 and 2017 most birds were recorded at altitudes above 120 m (i.e. above risk height > 30 to 120 m). However, the informative value of this result is limited due to the low number of birds / records.

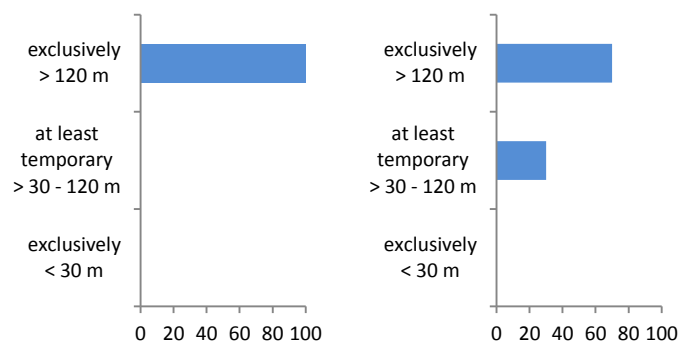

Relative abundance (percentage) of birds recorded at different altitude classes in the study area in **spring 2016** (n=4; left) and **2017** (n=10; right)

Greater Spotted Eagle

3. Daily Migration Pattern

No daily migration pattern can be derived by the few observations in spring.

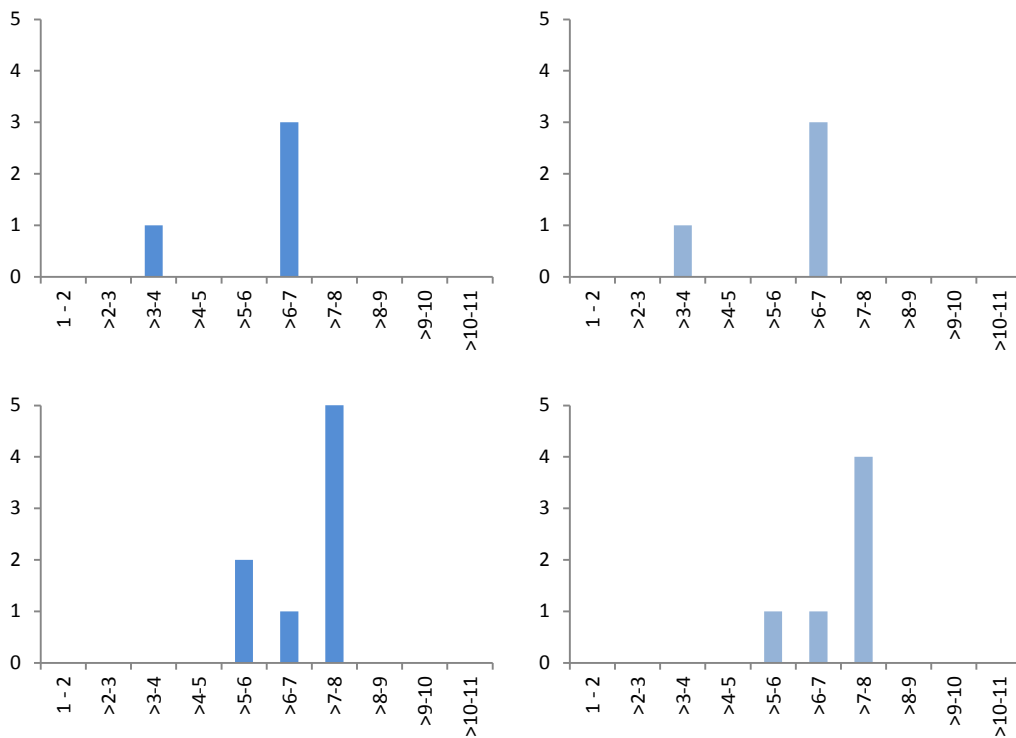

Number of birds (left) and records (right) registered in the study area at different hours after sunrise in **spring 2016** (above) and **2017** (below) - no observations were conducted in early morning and evening

4. Spatial Migration Pattern

Due to the low number of birds no remarkable differences appeared when comparing migratory activity in the study area.

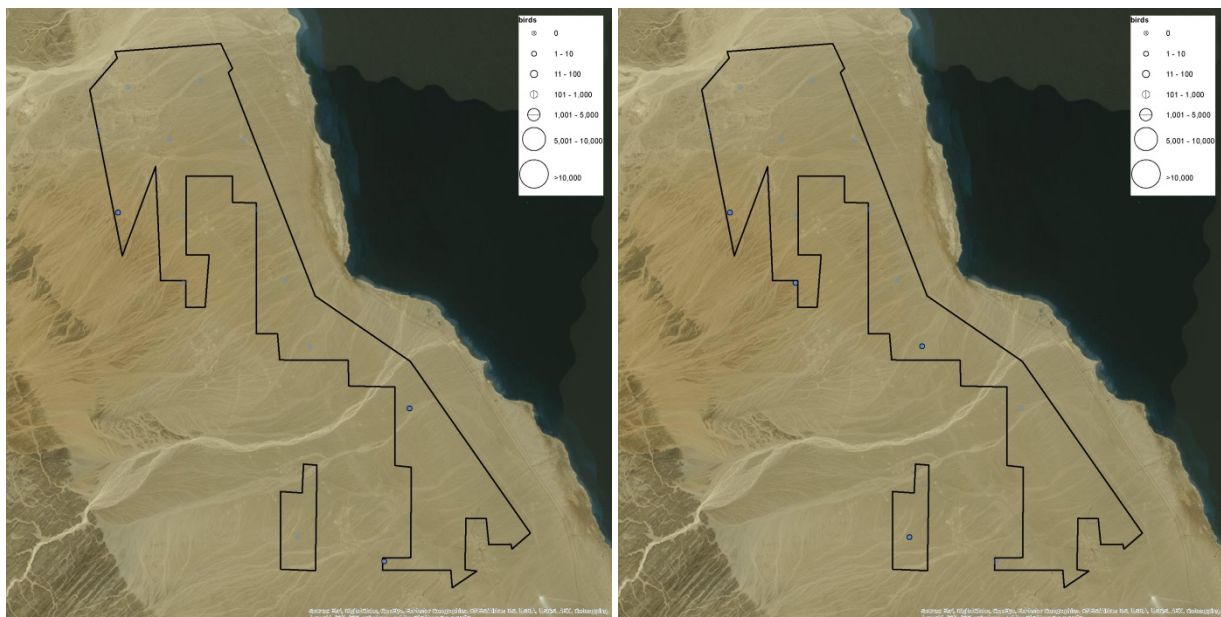

Number of birds (in abundance classes) registered within the study area in **spring 2016** (left) and **2017** (right)

Steppe Eagle

Steppe Eagle *Aquila nipalensis*

IUCN-Red List: Endangered

Flyway Population (individuals): 37,500

	autumn 2016		spring 2016		spring 2017	
	birds	records	birds	records	birds	records
study area	3	3	249	118	4,740	844
overall	3	3	249	118	4,740	844

1. Seasonal Migration Pattern (Phenology)

During autumn 2016 only three individuals were recorded during two days.

In spring 2017 the species was recorded mostly between end of February and mid of May. About 57 % were recorded between end of February and end of March. Another 27 % were recorded during April 12th and 13th. The number of records decreased from the beginning to the end of the study period in spring 2017.

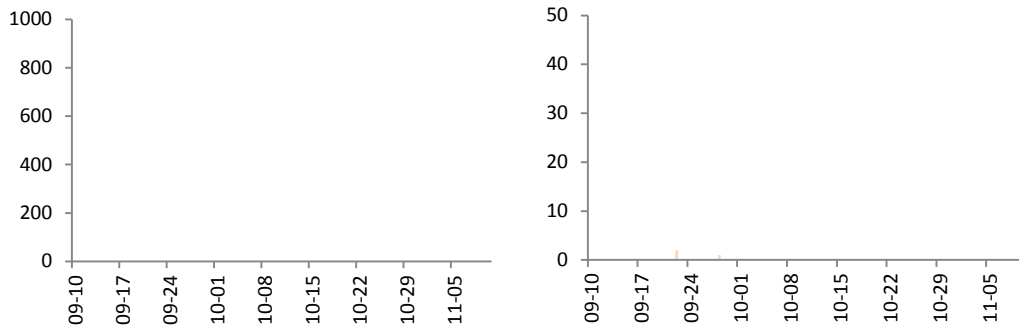

Number of birds (left) and records (right) registered in the study area in **autumn 2016**

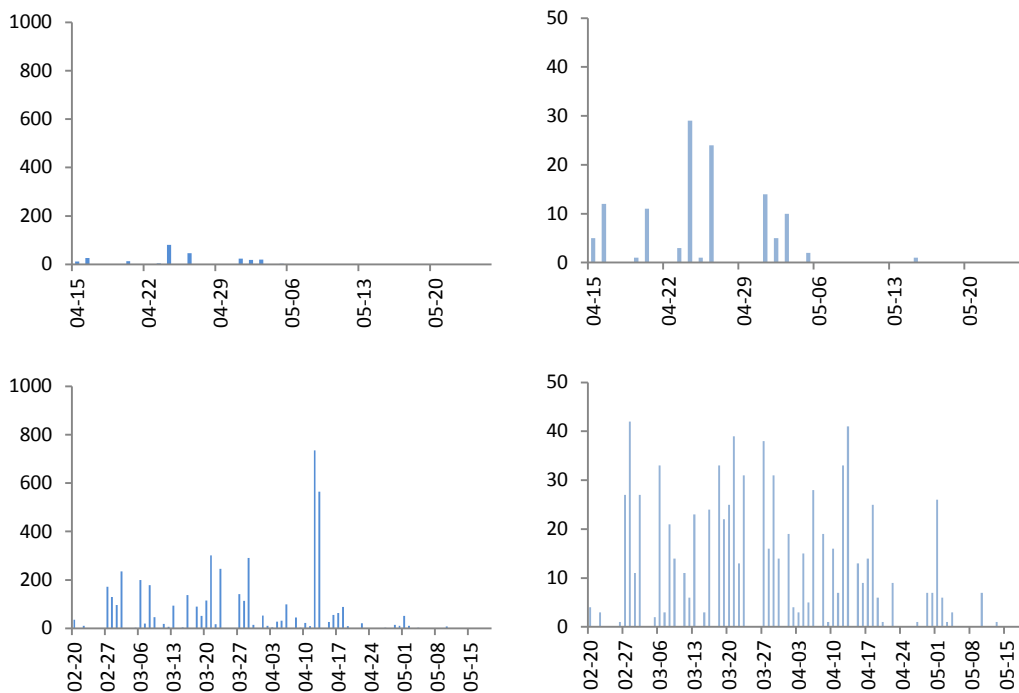

Number of birds (left) and records (right) registered in the study area in **spring 2016** (above) and **2017** (below)

Steppe Eagle

2. Flight altitude

In autumn one individual was recorded within each height class. In spring 2016 and 2017 most birds were recorded at altitudes above 120 m (i.e. above risk height > 30 to 120 m). The share of birds at least temporarily recorded at risk height in spring 2017, represents about 2.7 % of the flyway population.

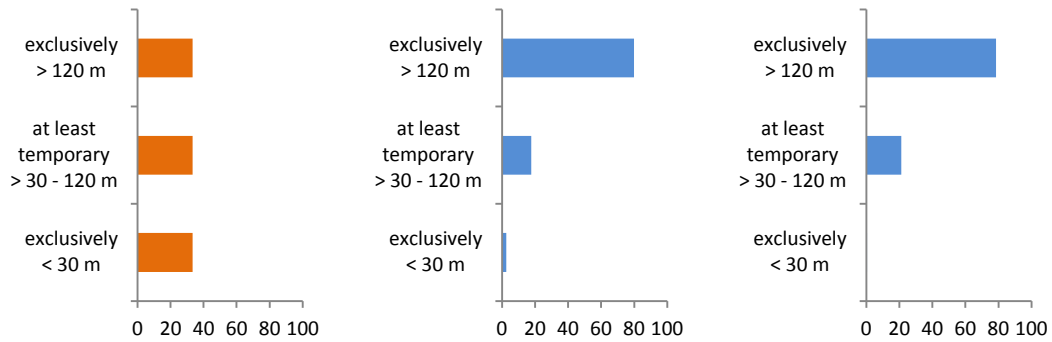

Relative abundance (percentage) of birds recorded at different altitude classes in the study area in **autumn 2016** (n=3; left), **spring 2016** (n=249; middle) and **2017** (n=4,740; right)



Steppe Eagle

Steppe Eagle

3. Daily Migration Pattern

In spring 2016 and 2017 the number of birds increased during the morning hours and then decreased again.

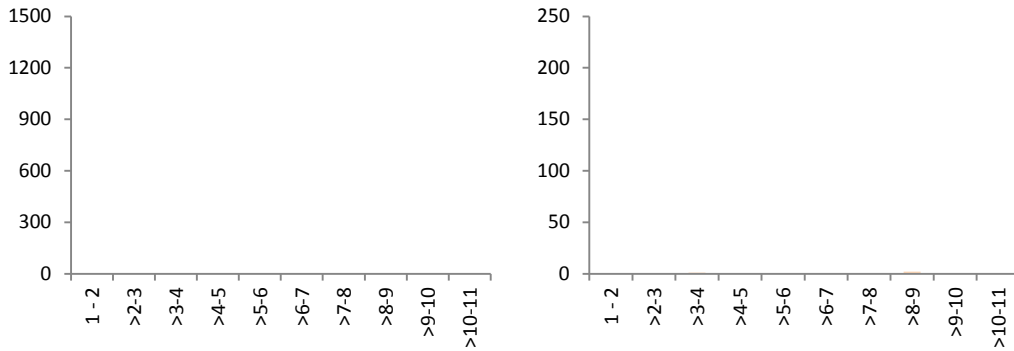

Number of birds (left) and records (right) registered in the study area at different hours after sunrise in **autumn 2016** - no observations were conducted in early morning and evening

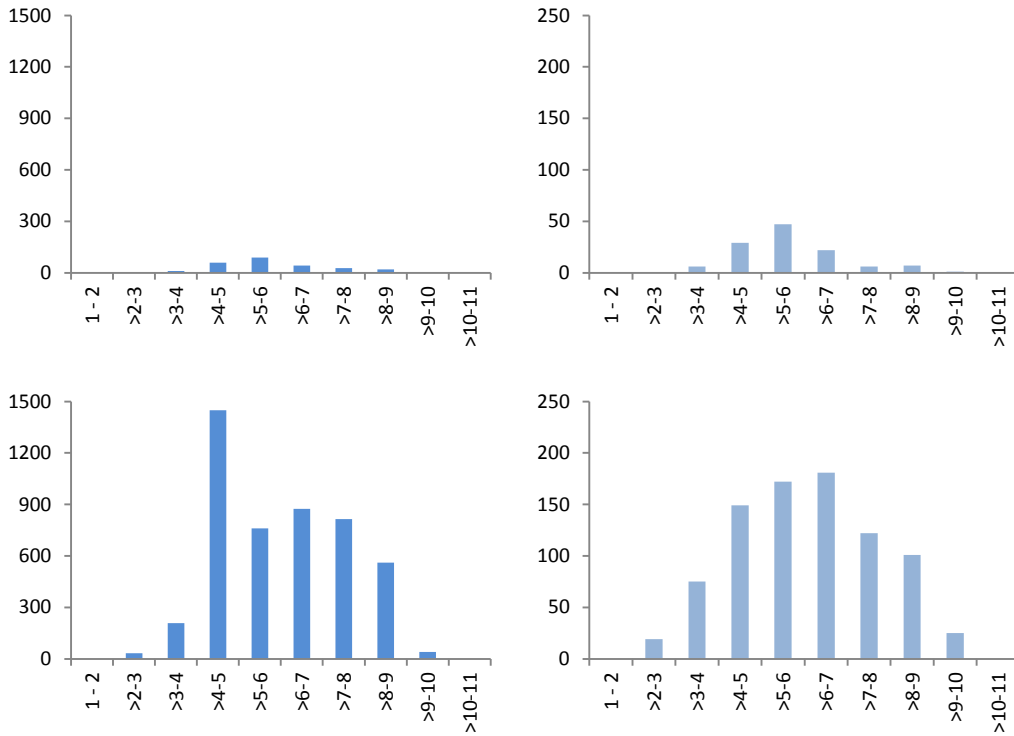

Number of birds (left) and records (right) registered in the study area at different hours after sunrise in **spring 2016** (above) and **2017** (below) - no observations were conducted in early morning and evening

Steppe Eagle

4. Spatial Migration Pattern

The number of recorded birds differed little amongst observation sites during each study period in autumn and spring.



Number of birds (in abundance classes) registered within the study area in **autumn 2016** (above), **spring 2016** (below left) and **2017** (below right)

Eastern Imperial Eagle

Eastern Imperial Eagle

Aquila heliaca

IUCN-Red List: Vulnerable

Flyway Population (individuals): 2,125

	autumn 2016		spring 2016		spring 2017	
	birds	records	birds	records	birds	records
study area	0	0	7	6	19	17
overall	0	0	7	6	19	17

1. Seasonal Migration Pattern (Phenology)

During autumn 2016 no Eastern Imperial Eagle was registered in the study area.

In spring 2016 and 2017 single birds were recorded during various periods of the study period.

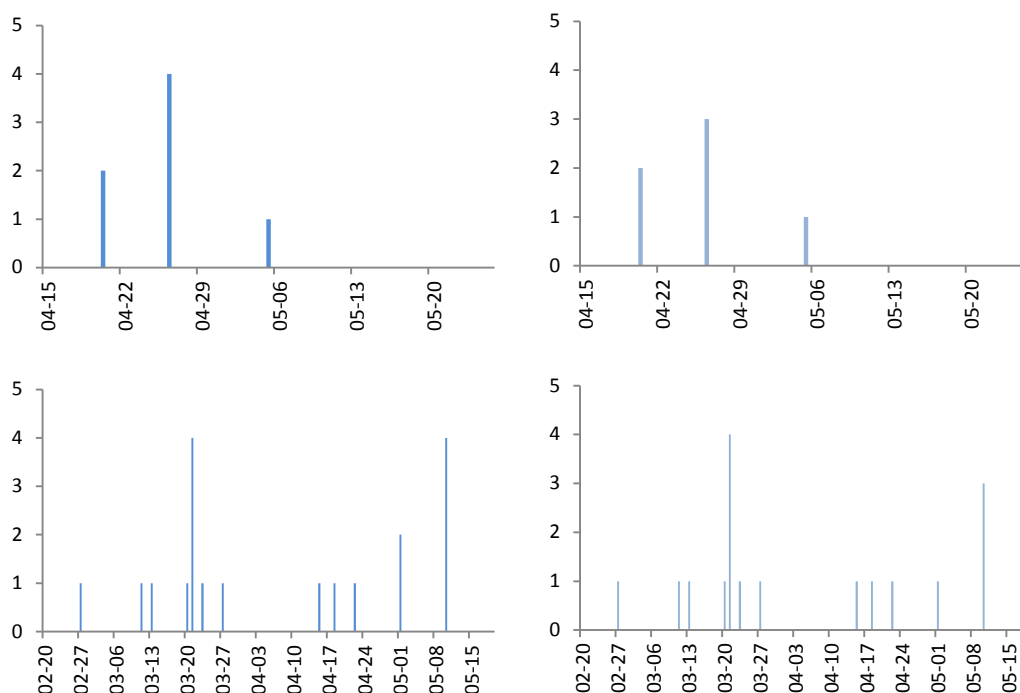

Number of birds (left) and records (right) registered in the study area in **spring 2016** (above) and **2017** (below)

2. Flight altitude

In spring 2016 4 of 7 birds were registered at risk height (i.e. > 30 to 120 m). In spring 2017 15 of 19 birds migrated above risk height. However, the informative value of this result is limited due to the low number of birds / records.

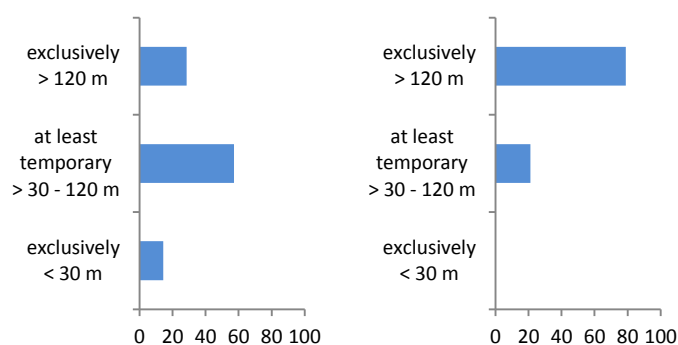

Relative abundance (percentage) of birds recorded at different altitude classes in the study area in **spring 2016** (n=7; left) and **2017** (n=19; right)

Eastern Imperial Eagle

3. Daily Migration Pattern

No daily migration pattern can be derived by the few observations in spring. By trend migratory activity increased during the late morning and decreased again towards the afternoon.

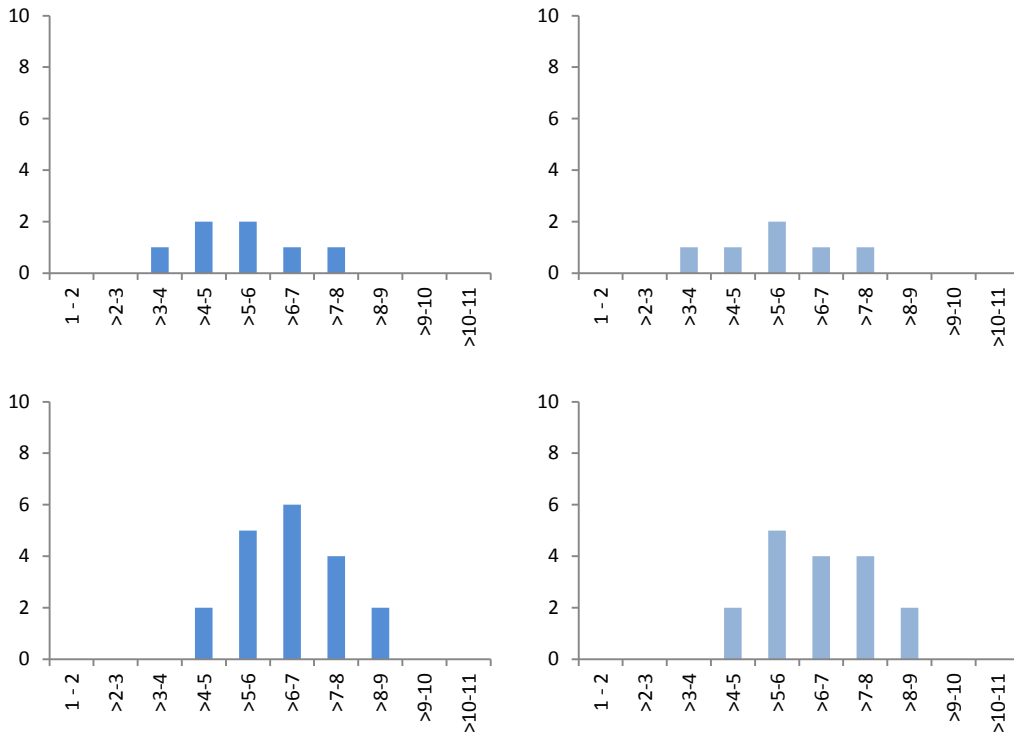

Number of birds (left) and records (right) registered in the study area at different hours after sunrise in **spring 2016** (above) and **2017** (below) - no observations were conducted in early morning and evening

4. Spatial Migration Pattern

Due to the low number of birds no remarkable differences appeared when comparing migratory activity in the study area.

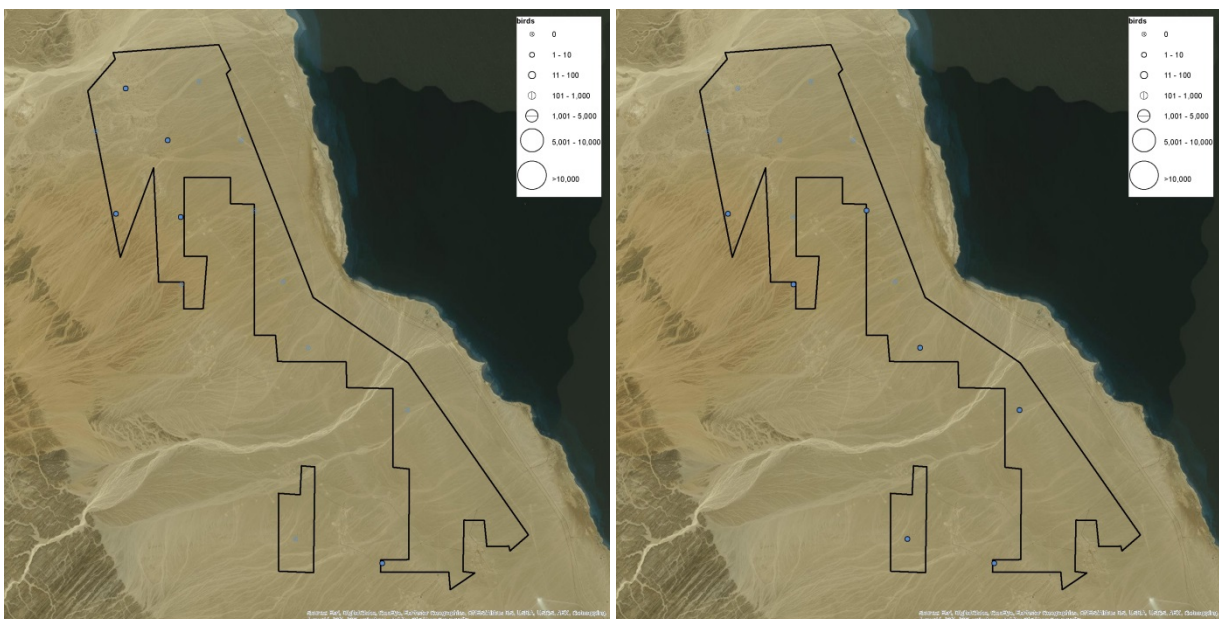

Number of birds (in abundance classes) registered within the study area in **spring 2016** (left) and **2017** (right)

Booted Eagle

Booted Eagle *Aquila pennata*

IUCN-Red List: Least Concern

Flyway Population (individuals): 5,000

	autumn 2016		spring 2016		spring 2017	
	birds	records	birds	records	birds	records
study area	3	3	81	72	153	97
overall	3	3	83	74	153	97

1. Seasonal Migration Pattern (Phenology)

In autumn 2016 single birds were recorded on three days.

In spring 2017 migration period lasted from end of March to mid of May. The majority of birds were recorded from mid of April onwards. About 56 % of all individuals occurred during April 12th, May 1st and 10th. In spring 2016 migratory activity peaked end of April.

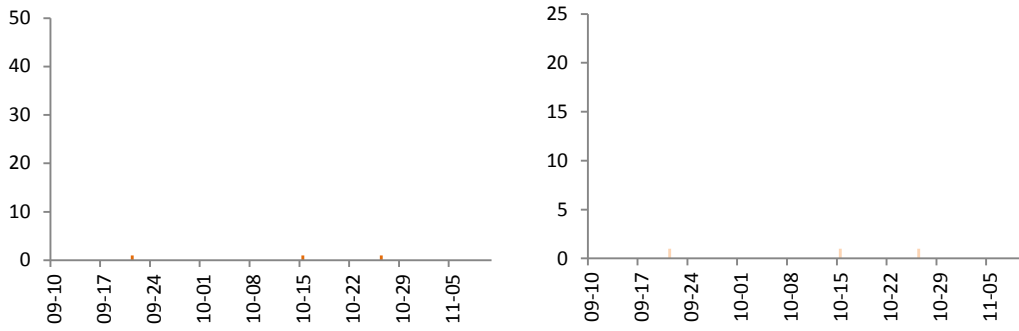

Number of birds (left) and records (right) registered in the study area in **autumn 2016**

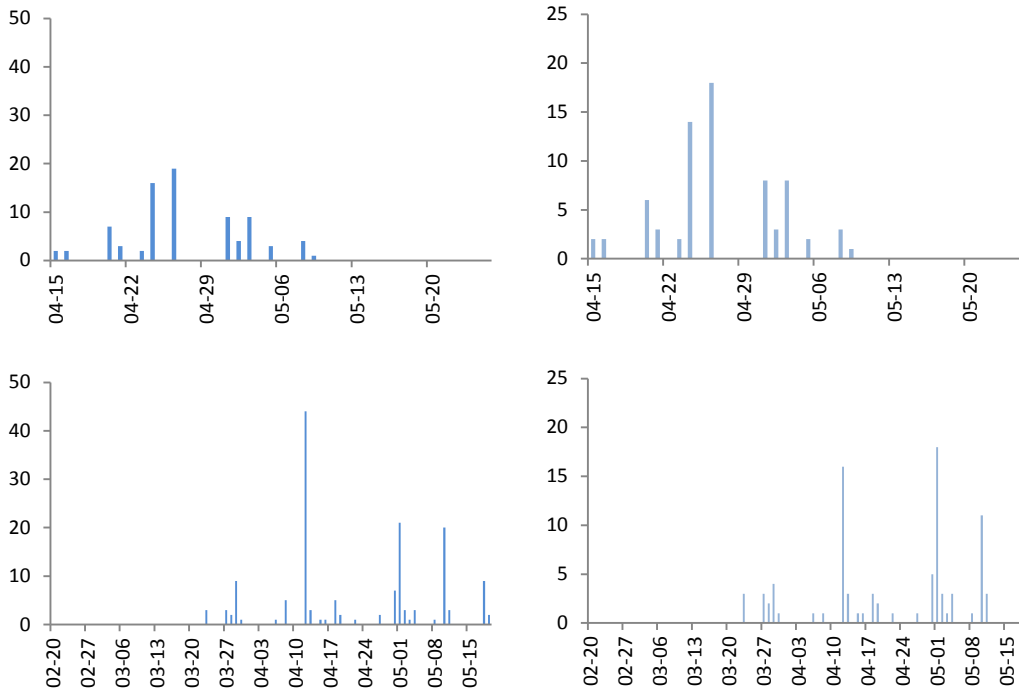

Number of birds (left) and records (right) registered in the study area in **spring 2016** (above) and **2017** (below)

Booted Eagle

2. Flight altitude

In autumn 2016 the registered individuals were recorded at altitudes above 120 m and thus above risk height (> 30 to 120 m).

In spring 2016 and spring 2017 the majority of birds occurred at altitudes above 120 m, too.

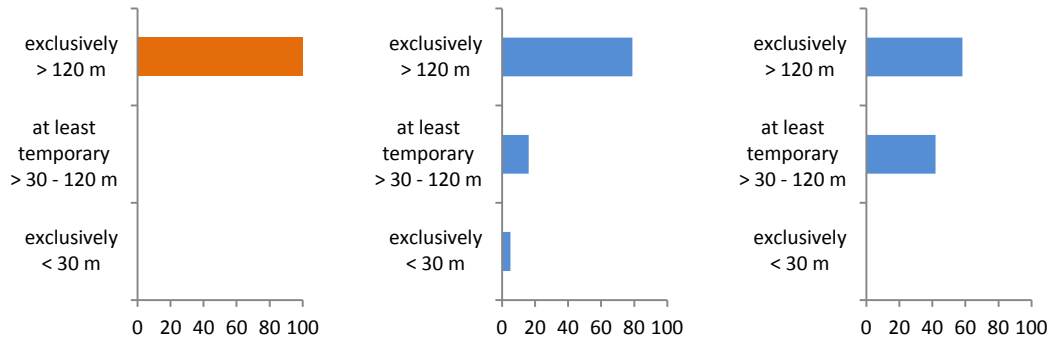

Relative abundance (percentage) of birds recorded at different altitude classes in the study area in **autumn 2016** (n=3; left), **spring 2016** (n=81; middle) and **2017** (n=153; right)



Booted Eagle

Booted Eagle

3. Daily Migration Pattern

Booted Eagles appeared during various times of the day in autumn and spring. The data at hand suggest an increase of migratory activity during the morning followed by a decrease starting about 6 hours after sunrise.

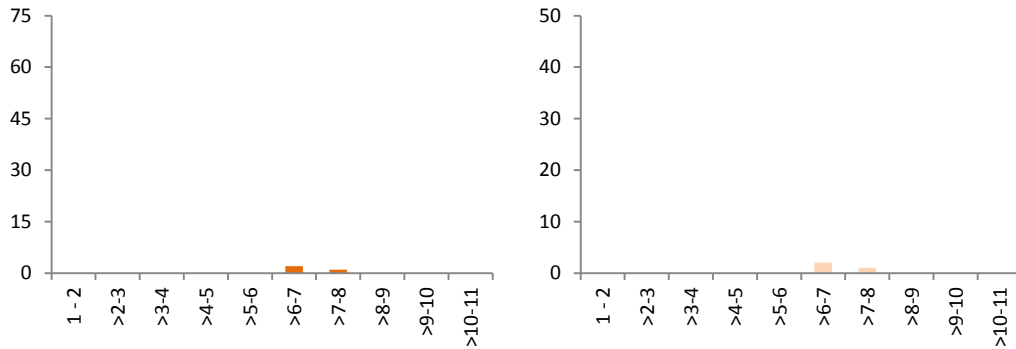

Number of birds (left) and records (right) registered in the study area at different hours after sunrise in **autumn 2016** - no observations were conducted in early morning and evening

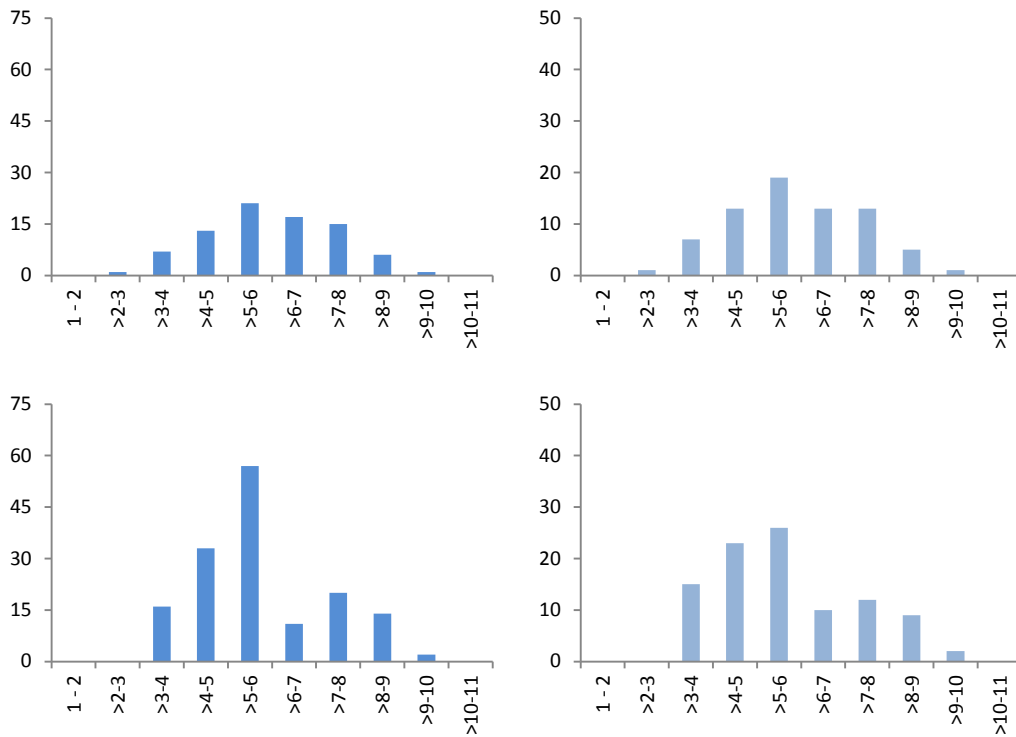

Number of birds (left) and records (right) registered in the study area at different hours after sunrise in **spring 2016** (above) and **2017** (below) - no observations were conducted in early morning and evening

Booted Eagle

4. Spatial Migration Pattern

No remarkable differences appeared when comparing migratory activity in the study area.



Number of birds (in abundance classes) registered within the study area in **autumn 2016** (above), **spring 2016** (below left) and **2017** (below right)

Common Kestrel

Common Kestrel *Falco tinnunculus*

IUCN-Red List: Least Concern

Flyway Population (individuals): unknown

	autumn 2016		spring 2016		spring 2017	
	birds	records	birds	records	birds	records
study area	10	10	28	25	99	75
overall	10	10	29	26	99	75

Remark: The flyway population of this species is unknown. The species is distributed within the Holarctic and is quite common with, for instance, a population of more than 800,000 birds in Europe (according to Birdlife International). Many birds of the population do not migrate as far as Egypt or Africa, but stay in Europe. To conclude, even though the flyway population is unknown, a large population can be assumed and the registered number of birds does not represent a significant portion of this population.

In the project area also sedentary individuals were observed in spring. Thus, a differentiation between sedentary and migrating birds was difficult and the following analysis may still include single sedentary birds.

1. Seasonal Migration Pattern (Phenology)

Common Kestrels occurred during various times of the study period in all seasons.

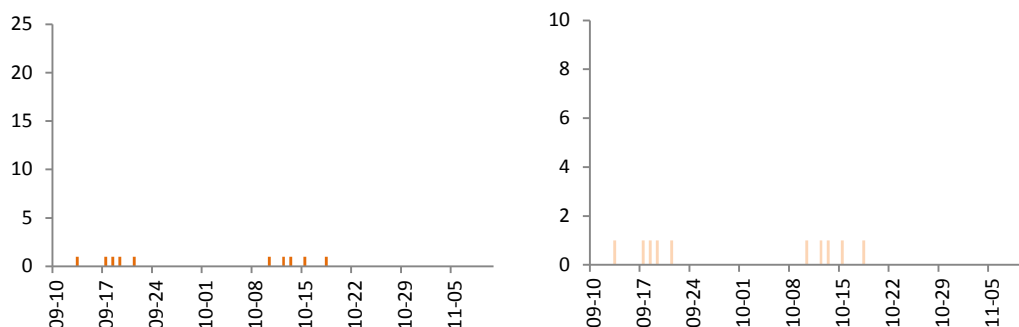

Number of birds (left) and records (right) registered in the study area in **autumn 2016**

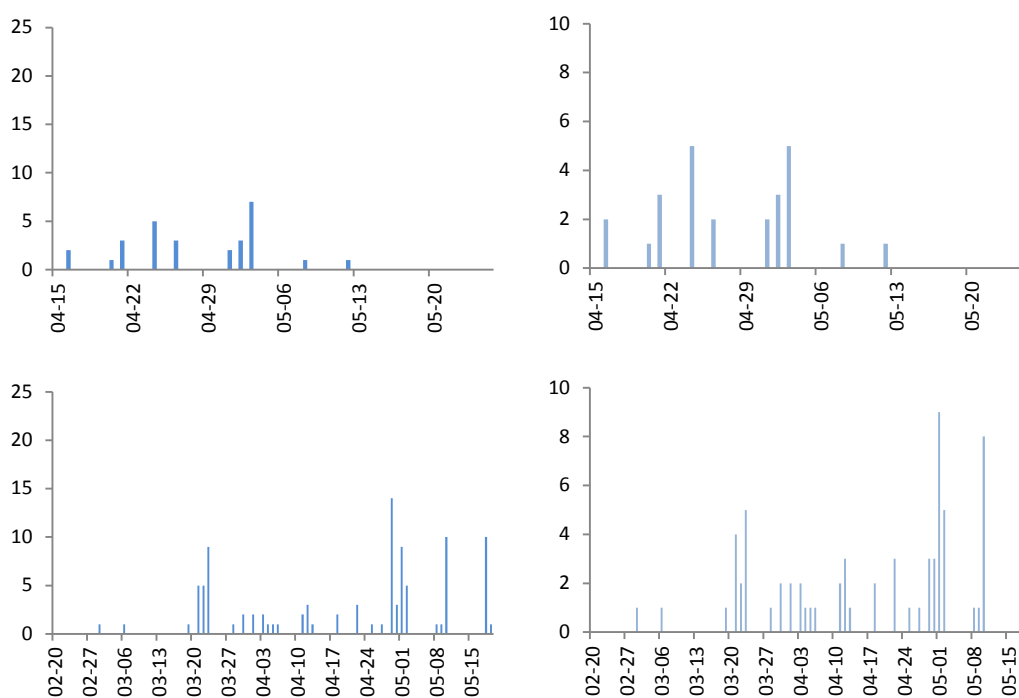

Number of birds (left) and records (right) registered in the study area in **spring 2016** (above) and **2017** (below)

Common Kestrel

2. Flight altitude

In all seasons birds were recorded within different height classes. However, the informative value of this result is limited for autumn and spring 2016 due to the low number of birds / records.

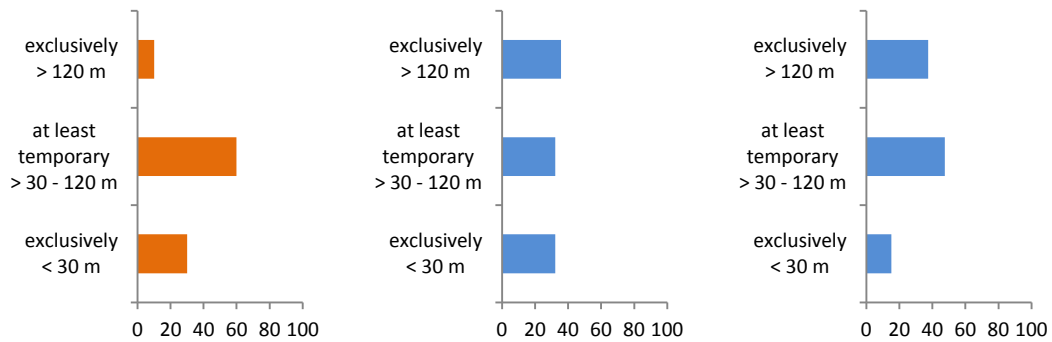

Relative abundance (percentage) of birds recorded at different altitude classes in the study area in **autumn 2016** (n=10; left), **spring 2016** (n=28; middle) and **2017** (n=99; right)

Common Kestrel

3. Daily Migration Pattern

Common Kestrels appeared during various times of the day in the study area in autumn and spring.

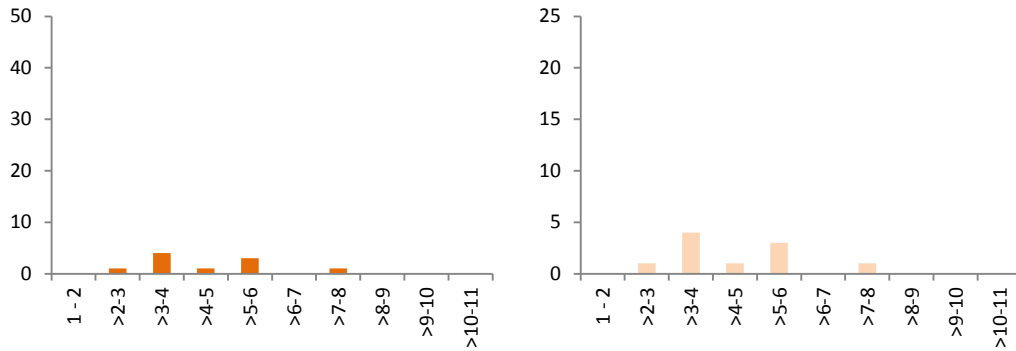

Number of birds (left) and records (right) registered in the study area at different hours after sunrise in **autumn 2016** - no observations were conducted in early morning and evening

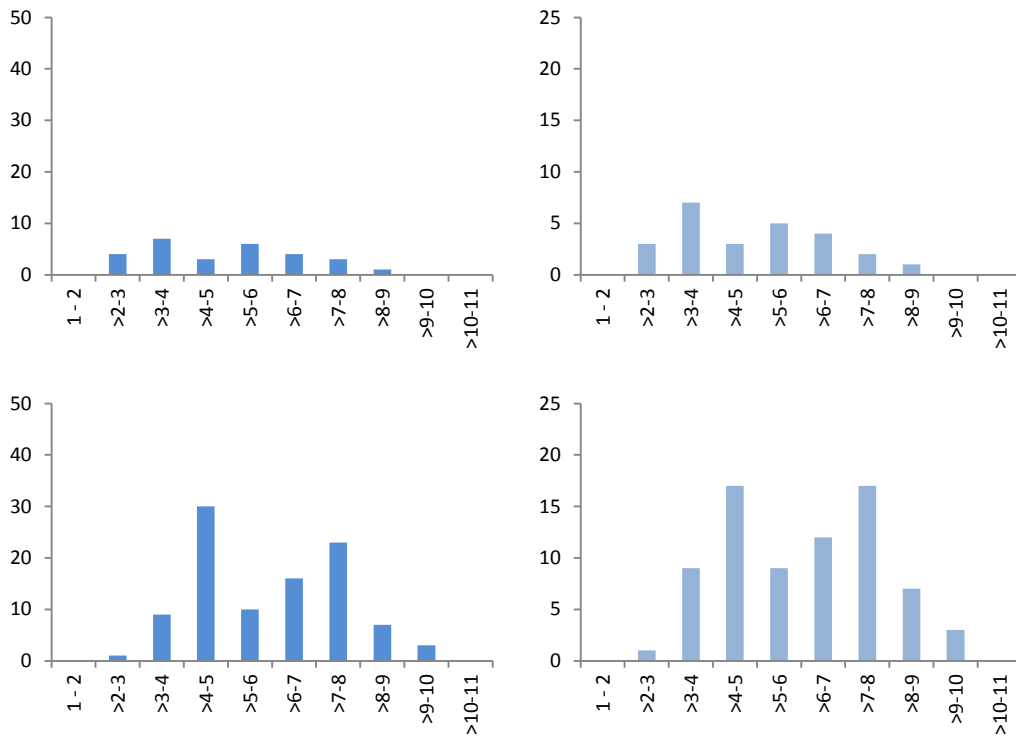

Number of birds (left) and records (right) registered in the study area at different hours after sunrise in **spring 2016** (above) and **2017** (below) - no observations were conducted in early morning and evening

Common Kestrel

4. Spatial Migration Pattern

No remarkable differences appeared when comparing migratory activity in the study area.



Number of birds (in abundance classes) registered within the study area in **autumn 2016** (above), **spring 2016** (below left) and **2017** (below right)

Common Crane

Common Crane

Grus grus

IUCN-Red List: Least Concern

Flyway Population (individuals): 50,000

	autumn 2016		spring 2016		spring 2017	
	birds	records	birds	records	birds	records
study area	0	0	0	0	1,831	10
overall	0	0	0	0	2,231	11

1. Seasonal Migration Pattern (Phenology)

In autumn 2016 and spring 2016 the Common Crane was not registered.

During spring 2017 the species was recorded on three days. The majority passed the study area on February 28th.

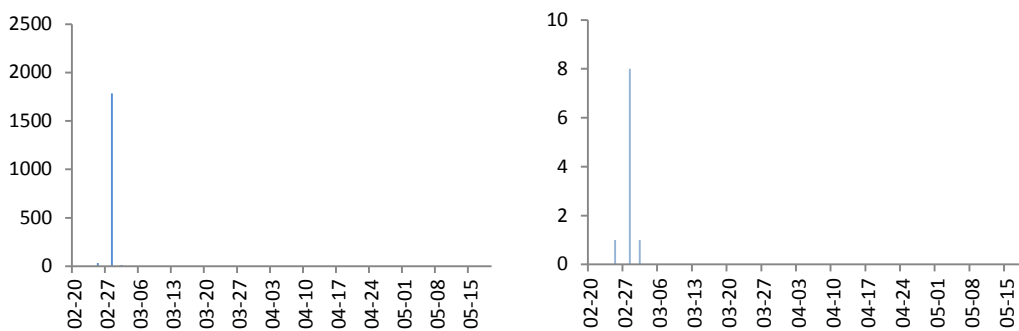

Number of birds (left) and records (right) registered in the study area in **spring 2017**

2. Flight altitude

The recorded birds flew mainly above 120 m and thus above risk height (> 30 to 120 m).

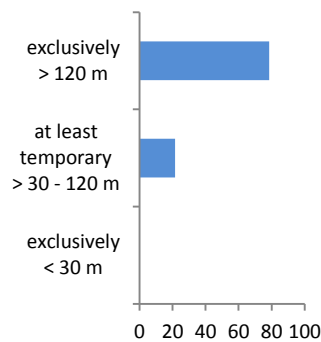

Relative abundance (percentage) of birds recorded at different altitude classes in the study area in **spring 2017** (n=1,831)

Common Crane



Common Cranes

3. Daily Migration Pattern

In spring 2017 Common Cranes were recorded during various times of the day. No pattern can be derived by a sample of ten observations.

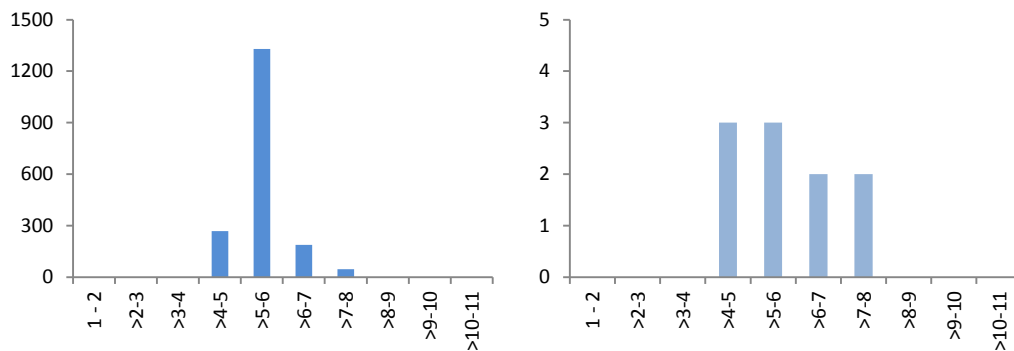

Number of birds (left) and records (right) registered in the study area at different hours after sunrise in **spring 2017** - no observations were conducted in early morning and evening

Common Crane

4. Spatial Migration Pattern

The difference in numbers of birds at the observation sites in spring 2017 was caused by single observation units on three days.

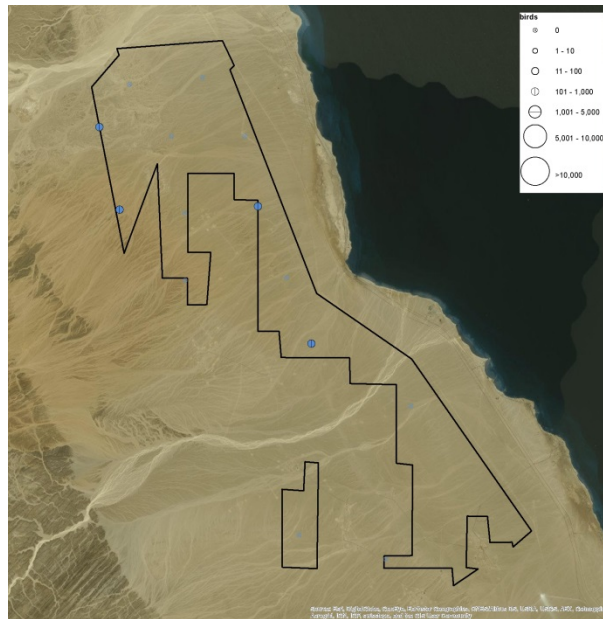

Number of birds (in abundance classes) registered within the study area in **spring 2017**

Strategic and Cumulative Environmental and Social Assessment

Active Turbine Management Program (ATMP) for Wind Power Projects in the Gulf of Suez

Annex V

Numbers of birds/records registered at the
14 observation sites (1 to 14)
in autumn 2016, spring 2016 and spring 2017



Annex Vb: Numbers of birds/records (rec) registered at the 14 observation sites (1 to 14) in spring 2016

species	scientific name	1		2		3		4		5		6F		7		8F		9		10		11		12		13		14	
		birds	rec	birds	rec	birds	rec	birds	rec	birds	rec	birds	rec	birds	rec	birds	rec	birds	rec	birds	rec	birds	rec	birds	rec	birds	rec	birds	rec
Great White Pelican	<i>Pelecanus onocrotalus</i>	300	1	4	1	50	1	15	1					48	2	148	3			300	1			2,150	2				
Black Stork	<i>Ciconia nigra</i>							32	2	3	1	89	9			36	4	2	1					10	1	12	5	8	2
White Stork	<i>Ciconia ciconia</i>	9,747	17			500	4	2,351	7	250	1	10,890	24	9,146	9	7,568	19	32	3	2,175	6	361	4	19	2	1,965	11	555	4
Osprey	<i>Pandion haliaetus</i>	1	1					7	3							1	1	1	1							1	1		
European Honey Buzzard	<i>Pernis apivorus</i>	66	4	295	6	31	3	2,635	26	1,411	19	816	40	1,064	13	2,749	45	14	7	45	4	18	4	113	12	941	54	424	26
Black Kite	<i>Milvus migrans</i>	4	3			1	1	23	6	32	11	271	58	79	5	160	33	51	12	2	2	6	2	227	8	89	39	85	13
Egyptian Vulture	<i>Neophron percnopterus</i>	2	2					3	2	4	2	25	15			7	5	7	4			2	2	4	3	14	9	10	4
Short-toed Snake Eagle	<i>Circaetus gallicus</i>	8	7			11	10	1	1	2	1	11	7	12	6	18	13	4	3	9	6	1	1	9	3	7	6	7	7
Marsh Harrier	<i>Circus aeruginosus</i>									2	1	1	1	1	1	6	6	1	1	2	2	1	1	8	4	5	5		
Pallid Harrier	<i>Circus macrourus</i>	1	1									2	2							1	1								
Montagu's Harrier	<i>Circus pygargus</i>											1	1							2	2					1	1		
Pallid / Montagu's Harrier	<i>Circus macrourus / pygargus</i>											2	2									1	1						
Harrier	<i>Circus spec.</i>																			1	1								
Levant Sparrowhawk	<i>Accipiter brevipes</i>											120	1	30	1	87	5	2	2							3	3	171	6
Eurasian Sparrowhawk	<i>Accipiter nisus</i>							3	1	4	3	5	4			8	7			5	4			6	4	12	8	2	2
Sparrowhawk spec.	<i>Accipiter spec.</i>																					2	2						
Steppe Buzzard	<i>Buteo buteo vulpinus</i>	59	14			52	5	196	15	100	5	1,187	93	173	8	1,019	41	129	19	31	4	7	7	138	8	576	67	528	45
Long-legged Buzzard	<i>Buteo rufinus</i>									1	1							1	1										
Buzzard	<i>Buteo spec.</i>									6	2					12	1									5	1		
Lesser Spotted Eagle	<i>Aquila pomarina</i>							3	2	1	1	80	31			24	11	21	5	1	1	1	1	6	2	17	8	2	2
Greater Spotted Eagle	<i>Aquila clanga</i>											2	2											1	1	1	1		
Steppe Eagle	<i>Aquila nipalensis</i>	29	10			5	3	17	6	1	1	13	9	13	3	3	3	13	11			1	1	4	2	80	41	70	28
Eastern Imperial Eagle	<i>Aquila heliaca</i>	2	2					1	1			1	1	2	1											1	1		
Booted Eagle	<i>Aquila pennata</i>	3	3	1	1			8	7	2	1	22	21	4	3	9	9	9	7					3	2	12	11	8	7
Eagle	-	1	1					1	1			13	5			5	3	1	1	1	1					6	3	6	5
Lesser Kestrel	<i>Falco naumanni</i>											1	1			2	1												
Common Kestrel	<i>Falco tinnunculus</i>					1	1	1	1	2	1	4	4	1	1	5	5	1	1	1	1	1	1	4	3	5	4	2	2
Lesser / Common Kestrel	<i>Falco naumanni / tinnunculus</i>											2	1															1	1
Eleonora's Falcon	<i>Falco eleonora</i>											2	2											1	1				
Sooty Falcon	<i>Falco concolor</i>					1	1							1	1							1	1						
Eurasian Hobby	<i>Falco subbuteo</i>									1	1	2	2			1	1					1	1	1	1				
Lanner Falcon	<i>Falco biarmicus</i>	1	1											1	1					1	1							1	1
Falcon	<i>Falco spec.</i>			2	1							1	1			1	1	1	1	1	1	1	1	2	2	1	1	1	1
unidentified Raptor	-	1	1									20	3	2	1	202	3					1	1	6	2	52	3	9	3

Annex Vc: Numbers of birds/records (rec) registered at the 14 observation sites (1 to 14) in spring 2017

species	scientific name	1		2		3		4		5		6F		7		8F		9		10		11		12		13		14	
		birds	rec	birds	rec	birds	rec	birds	rec	birds	rec	birds	rec	birds	rec	birds	rec	birds	rec	birds	rec	birds	rec	birds	rec	birds	rec	birds	rec
Great White Pelican	<i>Pelecanus onocrotalus</i>			21	1	200	1					100	1			424	2									15	2	10	1
Black Stork	<i>Ciconia nigra</i>	2	1	46	6	9	4					51	7	46	4	25	7	7	2			2	1	13	3	23	3	25	3
White Stork	<i>Ciconia ciconia</i>	1,561	13	9,130	9	5,238	11	2,807	4	3,075	6	27,472	22	5,016	17	4	10	4,976	9	5,850	3	2,955	8	1,700	7	4,635	11	14,785	20
Osprey	<i>Pandion haliaetus</i>	4	4	2	1	6	5	2	2	1	1			3	3			1	1							1	1		
European Honey Buzzard	<i>Pernis apivorus</i>	591	24	176	13	378	6	231	14	50	8	1,456	61	292	37	1,684	50	60	9	22	10	203	9	180	13	2,008	32	200	20
Black Kite	<i>Milvus migrans</i>	23	16	237	19	1,507	41	22	13	333	10	406	65	145	27	553	57	149	22	287	18	57	20	34	16	188	38	136	40
Egyptian Vulture	<i>Neophron percnopterus</i>	2	2			5	4					10	8	4	4	8	6	3	3	3	3	6	3	1	1	1	1	13	9
Short-toed Snake Eagle	<i>Circaetus gallicus</i>	31	22	10	7	30	22	27	19	13	8	59	42	15	12	50	32	40	24	12	6	46	16	13	12	46	27	80	53
Marsh Harrier	<i>Circus aeruginosus</i>	1	1	1	1	2	2	1	1			4	4	1	1	13	10	1	1					2	2	3	3	7	4
Pallid Harrier	<i>Circus macrourus</i>	1	1	1	1	1	1	3	3			1	1	2	2	1	1												
Montagu's Harrier	<i>Circus pygargus</i>	2	2	1	1					1	1	5	5	1	1	5	5	4	2				5	3	9	5	9	7	
Pallid / Montagu's Harrier	<i>Cir. macrourus / pygargus</i>			1	1			1	1	1	1	1	1																
Harrier	<i>Circus spec.</i>							2	2																	1	1		
Levant Sparrowhawk	<i>Accipiter brevipes</i>	1	1			2	2			3	2	7	3			2	1									807	5		
Eurasian Sparrowhawk	<i>Accipiter nisus</i>	1	1	1	1	1	1			3	2	4	3	1	1	1	1			1	1	1	1						
Sparrowhawk spec.	<i>Accipiter spec.</i>			4	1									1	1														
Steppe Buzzard	<i>Buteo buteo vulpinus</i>	339	57	2,091	32	12,360	121	176	32	8,195	25	3,209	177	887	51	1,537	89	892	82	215	21	1,059	69	238	44	450	79	868	111
Long-legged Buzzard	<i>Buteo rufinus</i>					2	2			2	2	5	5	2	2	5	5	3	3			1	1	1	1	2	2	3	3
Buzzard	<i>Buteo spec.</i>	6	2			10	2					3	2	6	2	52	5	147	5	3	1			5	2	11	7	65	8
Lesser Spotted Eagle	<i>Aquila pomarina</i>	7	1	1	1			3	2			14	8	2	1	6	6	2	1	8	5	9	7	7	1	11	7	2	2
Greater Spotted Eagle	<i>Aquila clanga</i>											2	1					3	2			2	1					3	2
Steppe Eagle	<i>Aquila nipalensis</i>	344	84	197	28	596	60	262	37	566	18	470	110	337	47	224	53	367	82	108	18	316	45	122	41	256	69	575	152
Eastern Imperial Eagle	<i>Aquila heliaca</i>											7	5			3	3	1	1			4	4	1	1	1	1	2	2
Booted Eagle	<i>Aquila pennata</i>	3	3	1	1	8	8	2	2	6	2	39	26	24	6	17	15	8	6	3	3	6	4	9	4	2	2	25	15
Eagle	-	1	1	1	1	21	3			1	1	1	1	2	2			1	1								24	7	
Lesser Kestrel	<i>Falco naumanni</i>															1	1												
Common Kestrel	<i>Falco tinnunculus</i>	1	1			1	1	2	2	4	3	15	14	2	2	17	14	15	10	7	7	4	4	9	6	5	5	17	6
Eleonora's Falcon	<i>Falco eleonora</i>											1	1																
Sooty Falcon	<i>Falco concolor</i>													1	1														
Lanner Falcon	<i>Falco biarmicus</i>					1	1									1	1												
Barbary Falcon	<i>Falco pelegrinoides</i>											1	1																
Falcon	<i>Falco spec.</i>	2	2									1	1	1	1			1	1				1	1					
unidentified Raptor	-	11	6	4	4	37	7	91	7	1	1	1	1	6	6	6	1	20	1	1	1	50	1	10	3	70	4	155	8
Common Crane	<i>Grus grus</i>					500	1					580	5			111	2					640	2						

Strategic and Cumulative Environmental and Social Assessment

Active Turbine Management Program (ATMP) for Wind Power Projects in the Gulf of Suez

Annex VI

Potential Effects of Operating Wind Farms on Migratory Soaring Birds



1. Possible Effects of Operating Wind Farms on Migratory Soaring Birds

The major potential hazards to migrating birds are mortality due to collision as well as barrier effects.

1.1 Collision Risk and Mortality

Wind turbines seem to add an obstacle for bird movements and research has shown that birds fly into rotor blades. Although some studies have recorded bird collisions, other studies give evidence that birds could detect the presence of wind turbines and generally avoid them.

1.1.1 Results of Collision Risks at Different Wind Farms

As one of the first, Erickson et al. (2001) collected data from many studies conducted at different wind farms in the U.S. The results indicate an average of 2.19 avian fatalities per turbine per year in the U.S. for all species combined and 0.033 raptor fatalities per turbine per year. At different wind farms in Europe the annual number of dead birds per turbine varies between 0.04 (Percival 2000) and 35.00 (Everaert et al. 2002) depending on site characteristics and bird densities. Madders & Whitfield (2006) pointed out that simply presenting mortality rates per turbine or per installed MW, in the absence of further information on the abundance of birds (or birds at risk of death), does little to inform about the collision risk by a wind farm. And Langston & Pullan (2004) suggested that a low collision rate per turbine does not necessarily mean that collision mortality is insignificant, especially in wind farms comprising several hundreds or thousands of turbines.

Comparably high mortality rates due to collision have been recorded at large wind farms in areas with high concentrations of birds: Altamont Pass in California (Hunt 1995, Orloff & Flannery 1992, Smallwood & Thelander 2004, 2008, Thelander & Smallwood 2007) and in the Campo de Gibraltar region (Cádiz) in Spain (Barrios & Rodriguez 2004). In particular, large numbers of raptors have collided with wind turbines at these sites, including substantial numbers of Golden Eagles (*Aquila chrysaetos*) and Griffon Vultures (*Gyps fulvus*). These wind farm areas are characterized by large numbers of turbines (c. 7,000 at Altamont and 256 at Cádiz, which are often closely packed together) and by predominantly small turbines comprised of lattice towers and high-speed rotors relatively close to the ground (Percival 2005). Both areas are located in mountainous surroundings, sustain important food resources and, consequently, high densities of birds, which thus are susceptible to collisions with turbines.

As with Altamont or Cádiz, most of all investigated wind farms affect stationary (breeding or wintering) birds and / or small passerines migrating at night. Thus, there is a great lack of information about collision risk for migrating birds, in particular about migrating raptors or other large birds. Most studies, which also focus on migrating birds, were made for offshore wind farms (see for example Hüppop et al. 2006, Vanermen et al. 2013) and thus are about migrating waterbirds and passerines.

During a 14-month study, which included two autumn migration periods, only two bird carcasses were found at a wind farm ("EEE"66 turbines) near the Strait of Gibraltar: a Griffon vulture, which is a stationary (wintering) bird species in the region, and a Short-toed Snake Eagle. Janss (2000) estimated that about 45,000 Griffon Vultures and 2,500 Short-toed Snake Eagles fly over the wind farm per year.

In contrast to these findings Barrios & Rodriguez (2004), during a one-year period at a wind farm (called "PESUR", 190 turbines) located less than 10 km away from the above mentioned study area, found 28 Griffon Vultures, twelve Common Kestrels, three Lesser Kestrels, two Short-toed Snake Eagles, one Black Kite and two White Storks. The authors estimated a mortality rate of 0.36 raptors per year per turbine. Considering the number of turbines, such increases in mortality rates may be

significant for some birds, especially large, long-lived species with a generally low annual productivity and long maturation. Barrios & Rodriguez (2004) concluded that mortality at wind power plants reflects a combination of site-specific (wind-relief interaction), species-specific and seasonal factors.

During a three-year study (2000-2002) 13 wind power plants containing 741 turbines were studied in Navarra (Spain; Lekuona & Ursúa 2007). Thirty seven study plots containing 277 turbines were selected for fatality searches and behavioural bird observations. Overall 345 bird fatalities were recorded. Most dead birds were raptors (72.8 %) with the Griffon Vulture representing 63.1 % of raptor fatalities. Most raptors were killed during spring (March to June). By contrast, all three Lesser Kestrels were found during postbreeding migration, because there was a postbreeding roost near a wind plant.

At the wind farm “Al Koudia” (84 turbines) in northern Morocco, corpse searches were done over a three-month period in 2001 (El Ghazi & Franchimont 2001). Only two carcasses were found in autumn 2001 (one Pallid Swift (*Apus pallidus*) and one Woodlark (*Lullula arborea*), but no raptor or large bird). In autumn 2000, four other birds (mainly local, stationary species) were found by chance. It must be mentioned that the results might lead to an underestimation of collision risk, because no correction factors (e.g. for search efficiency or scavenger activity) were used.

At a wind farm (220 turbines) at the western bank of the Gulf of Suez (Egypt) corpse searches were carried out over a four-week period in spring 2007 (Bergen 2007). Body parts, feathers and bones of three birds were found, which had died weeks or months ago — possibly by collision with a turbine. No fresh bird corpse was found. Due to the characteristics of the study area and the high intensity of investigation, search efficiency and / or scavengers were not regarded to play an important role. Thus, the results strongly indicate that the number of collisions was very low if not zero throughout the period of investigation. It must be pointed out, however, that the study is limited due to the short period of investigation.

In autumn 2014, a total of 24 bird casualties are documented in and around KfW wind farm (with 30 operating turbines at that time) (EcoConServ 2015). Most casualties collided at the existing power line and at guide wires for wind measuring instruments. Two birds (one White Stork found on 24/8 and one Steppe Buzzard found on 22/9) most probably died due to a collision with an operating turbine in KfW wind farm.

Based on the monitoring results obtained in autumn 2014 EcoConServ (2015) estimated the expected number of fatalities at KfW wind farm during autumn migration using the collision risk-model (CRM) developed by Band (e.g. Band 2000, Band et al. 2007). As a result a total of about 87 White Storks, 16 Great White Pelicans and 4 European Honey Buzzards were believed to collide on average at KfW wind farm every autumn season. However, the explanatory power of the CRM is limited (see Chapter 6.1.1) and, thus, the estimates lack a reasonable basis.

In spring 2016 an additional survey on collision victims was conducted at KfW wind farm for a period of one month (late March to late April; Al Hasani & Al-Mongy 2016). At the same time a shutdown on demand-program was run at KfW wind farm. A total of three casualties were found under the turbines during systematic carcass searches within the period of one month: one Collard Flycatcher (*Ficedula albicollis*), one unidentified raptor species (only large feathers attached to skin were detected) and one old Harrier species (Al Hasani & Al-Mongy 2016).

Occasional fatality searches at wind turbines in Hurghada wind farm did not reveal any evidence of bird mortality (Baha El Din 1996).

1.1.2 Factors Influencing Vulnerability to Collision

The risk of collision depends on a broad range of external and internal factors (Johnson et al. 2000). After having reviewed more than 200 documents about this topic Marques et al. (2014) assume species-, site- and turbine-specific factors determine the collision probability at a certain site.

1.1.2.1 Weather, Visibility and Season

Collision risk seems to be greatest in poor flying conditions, such as strong winds that affect the birds' ability to control flight manoeuvres, or in rain, fog, and on dark nights when visibility is reduced (Langston & Pullan 2004, Winkelman 1992). But collisions occurred in conditions of good visibility, too: all of the 68 collisions at turbines of the above mentioned wind farm "PESUR" occurred on clear days (Barrios & Rodriguez 2004); and collision of Vultures occurred rarely in strong winds, which could have indicated little manoeuvrability by the Vultures (see below).

At the wind farm "PESUR" all Vultures died between October and April, with 66.7 % of all accidents taking place between December and February (although the Griffon vulture is a resident species in the region). Barrios & Rodriguez (2004) assumed that the seasonal pattern of Vulture deaths might be explained by flight behaviour. As is known, Griffon Vultures need vertical air currents to gain height. In winter low temperatures make thermals scarcer. Birds are thus constrained to gain height with slope updrafts, whose force on most winter days may be insufficient to lift Vultures well above the ridge, thereby exposing them to wind turbines.

1.1.2.2 Site-specific factors

It is quite obvious that a higher collision rate is to be expected at locations with high bird densities (Langston & Pullan 2004), especially by species vulnerable to collision. When comparing wind energy facilities, it appears that birds tend to be killed at rates that are proportional to their relative abundance amongst wind farms (Smallwood & Thelander 2004). However, there are several wind farms where the correlation between usage by birds and fatality is low (Erickson et al. 2001). An investigation at several wind power plants in Spain also confirmed that the relative abundance of species does not predict the relative frequency of fatalities (Lekuona & Ursúa 2007). For the wind farm areas "PESUR" and "EEE" de Lucas et al. (2008) did not find a close relationship between bird abundance and the number of collisions victims. For these areas species-specific and topographic factors seem to determine the collision probability.

California Energy Commission (2002) and Orloff & Flannery (1992) suggested that the abundance of ground squirrels within the Altamont Pass Wind Resource Area might significantly increase raptor foraging, and thus collision risk. Within some wind farms in Navarra (Spain), Vultures and Kites were apparently killed because of the nearby livestock carcass and dump sites (Lekuona & Ursúa 2007).

Howell & Di Donato (1991) identified significant topographical features associated with collision mortality. Notably mountain passes and hill shoulders, which tend to be the preferred crossing places for soaring species, were associated with multiple collisions.

Field studies in the Altamont Pass resource Area have clearly shown that not all turbines have an equal probability of causing raptor fatalities (Morrison et al. 2007). While some turbines were involved in multiple fatalities, others killed none. Fifteen turbine strings, which are located in highly complex topographic areas, were responsible for 60 % of all raptor fatalities: 80 % of Red-tailed Hawk (*Buteo jamaicensis*) and 100 % of Golden Eagle.

The 190 wind turbines at the wind farm "PESUR" — which prompted a relatively high number of collisions (Barrios & Rodriguez 2004) — are arranged in rows along the ridges of mountains or hills, too. However, the wind farm which is less than 10 km away from "PESUR" and which is arranged in a similar way, yielded evidence of only very few collision victims (de Lucas et al. 2004).

1.1.2.3 Turbine-specific Factors

Orloff & Flannery (1992) suggested that the high collision rate at Altamont Pass might be correlated to the lattice towers of the wind turbines which provide many perches, thus attracting birds, particularly raptors, into the collision-risk zone. However, recent investigation showed that perching on wind turbines is a less important factor contributing to mortality than previously suspected (Smallwood & Thelander 2004).

Percival (2005) assumed that collision risk at small turbines with high-speed rotors and with the turbines often packed closely together is higher.

Differences in collision rates also appear between turbines within a single wind farm although the same turbine type is used: in the wind farm “PESUR” a single group of 28 turbines (from 190) was responsible for 57 % of Griffon vulture mortality. These turbines were arranged in two rows with little space between consecutive turbines (Barrios & Rodriguez 2004). However, little or no risk was recorded for five turbine rows having exactly the same windwall spatial arrangement.

Smallwood & Thelander (2004) found that wind turbines were most dangerous at the ends of turbine strings, at the edges of gaps in strings, and at the edges of clusters of wind turbines. Furthermore, most isolated wind turbines killed disproportionately more birds.

Barclay et al. (2007) found that neither rotor diameter nor tower height have an effect on bird fatalities.

1.1.2.4 Species-specific Factors

Manoeuvrability and flight behaviour might be crucial factors to explain differences in collision risks between species (Drewitt & Langston 2006).

Especially soaring birds, like Griffon Vulture or Golden Eagle, are believed to be particularly vulnerable to collision with wind turbines (Langston & Pullan 2004), because of their lower manoeuvrability and their dependence on thermals. In contrast, at “PESUR” other soaring birds, such as Common Buzzards or Short-toed Snake Eagles, often circled together with Vultures in slope updrafts but did not closely approach the turbine blades and rarely collided with them. Barrios & Rodriguez (2004) suggest that these species have lower wing loads than Vultures, and make a more efficient use of the ascending currents, gaining altitude faster and farther away from the turbines.

In the Altamont Pass Wind Resource Area Smallwood et al. (2009) found that fatality rates were high for Red-tailed Hawk and American Kestrel (*Falco sparverius*), but low for Common Raven (*Corvus corax*) and Turkey Vulture (*Cathartes aura*), indicating specific behaviours or visual acuity differentiated these species by susceptibility to collision.

Ornis Consult (1999) subdivided soaring birds into four different categories depending on manoeuvrability and flight behaviour. On the basis of this classification the vulnerability of different species to collision can be deduced (see Table). Due to the number of factors affecting the risk of collision, it is very difficult to transfer the results obtained at a particular wind farm to another. At present, there is insufficient information available to form a reliable judgement on the scale of collision at a proposed wind farm. However, the results of a current study show that migrating raptors adjust their flight path to avoid wind farms effectively reducing the risk of collision (Cabrera-Cruz & Villegas-Patracá 2016).

Table: Assessment of species-specific vulnerability to collision depending on manoeuvrability and flight behaviour (adapted from Ornis Consult 1999)

category	description	species	vulnerability to collision
very passive fliers	very dependent on thermals, avoid large bodies of water	Egyptian Vulture, Short-toed Snake Eagle and all Eagles of the genus Aquila	very high
less passive fliers	less dependent on thermals, majority avoids large bodies of water	Buzzards, Kites, Honey Buzzard, Storks, Cranes and Pelicans	medium to high
less active fliers	rely on thermals and avoid large bodies of water to a limited degree	Harriers and Sparrowhawks	low to medium
very active fliers	do not dependent on thermals, do not avoid large bodies of water	Falcons	very low

Nevertheless, collision risk seems to depend not only on manoeuvrability and flight behaviour but also to a large (or maybe larger) extent on species-specific avoidance behaviour.

The high number of collided Common Kestrel (a very active flier that does not depend on lifting air currents) and maybe Griffon Vultures too, might be explained with the absence of avoidance behaviour. At "PESUR" Kestrels sometimes perched on lattice towers, and Vultures frequently flew at close distance to the blades, or between two adjacent turning turbines (Barrios & Rodriguez 2004). Soaring flights at low wind speeds and crossing flights that commenced below blade height increased the risk of collision, as Vultures showed little reaction to the turbine with only 2 % altering their approaching flight pattern.

In the wind farm at the western bank of the Gulf of Suez the majority of birds migrating at altitudes below 100 m showed clear avoidance behaviour in the presence of the wind turbines (Bergen 2007). While Steppe Buzzards predominately changed flight direction and avoided to enter the wind farm area altogether, most Black kites increased altitudes and subsequently entered the wind farm at heights above rotor blades but also at heights of the area swept by the rotor. Thus, they passed over or through the wind farm. Furthermore, the results of the study indicate that birds migrating individually are less sensitive to the presence of wind turbines than flocks. Large flocks seem to avoid wind turbines at greater distances.

The preferred altitude of migration is likely to be another factor effecting collision risk in a species-specific way. Most birds of such species that tend to migrate at altitudes well above 200 m (e.g. Eagles) are unlikely to come close to the area swept by rotors of wind turbines. Other species that prefer to migrate at altitudes around turbine height might often come into the range of rotors and hence face a risk to collide.

Furthermore the altitude of migration above ground can be influenced by site, depending on the availability of thermal uplifts. At the western coast of the Gulf of Suez birds arrive mainly in altitudes below 200 m after having crossed the Red Sea in autumn (ecoda 2011). Those birds cannot make use of any thermal uplifts and thus arrive at low altitudes. In Israel White Pelicans, White Storks, Lesser Spotted Eagles and Honey Buzzards flew on average at height bands between 344 and 1,123 m above ground during autumn and spring migration (Lesham & Yom-Tov 1996) by making extensive use of thermal uplifts.

There are indications that migrating passerines might be vulnerable to collision, especially when migrating at night (because of poor visibility; Langston & Pullan 2004). Collisions of passerines were recorded at several wind farms (Erickson et al. 2001). But mass collisions, which occurred at lighthouses during some nights, were not documented at wind turbines. Until now, collision risk of nocturnal migrants at onshore wind farms does not seem to be a major concern (e.g. Krijgsveld et al. 2009), possibly for several reasons:

- Usually nocturnal migration by passerines is at altitudes well above turbine height (e.g. Alerstam 1990, Carlbro 2010), so there is a very low potential for these birds to come into the collision risk zone. It can be suggested that nocturnal migrants should be most vulnerable during take-off soon after sunset and during descent. Furthermore, birds facing strong headwinds, forcing them to fly at lower altitudes, might face an increased risk of collision.
- Due to the large populations of most passerine species, they are not of major conservational interest. Results from studies in the United States indicate that the levels of fatalities are not considered significant enough to threaten local or regional population levels (Sterner et al. 2007).
- Most passerines have an r-selected reproductive strategy: individuals are short-lived, mature rapidly, have many offspring and a high adult and juvenile mortality. Consequently, additional mortality caused by wind turbines is unlikely to have a significant effect on populations of most passerine species.
- Mortality of passerines seems to be much higher at other man-made structures compared to mortality at wind turbines (Erickson et al. 2001).

1.1.2.5 Individual Factors

Finally, collision risk might be influenced by individual attributes of a bird (e.g. age, experience or fitness). It is quite obvious that the risk of collision varies depending on the stage of a bird's annual cycle (breeding, roosting or migrating).

Some studies indicate that immature birds are more vulnerable than adults, a phenomenon which may be attributed to the inexperience of younger birds. However, within the Altamont Pass Wind Resource Area most Golden Eagle mortalities were not juveniles but subadults and non-breeding adults (California Energy Commission 2002).

At "PESUR", "Al Koudia" as well as three windfarms in the Netherlands collision victims were usually species with resident populations rather than species appearing during migration (Barrios & Rodriguez 2004, El Ghazi & Franchimont 2001, Krijgsveld et al. 2009).

1.1.2.6 Conclusion

Many studies have shown that birds are generally able to avoid collisions with wind turbines and do not simply fly into them blindly (e.g. de Lucas et al. 2004, Desholm 2006, Dirksen et al. 1998). Nevertheless, at a few locations relevant numbers of collision victims were found, leading to significant increases in mortality rates and possibly to population decreases.

As shown, the scale of collision depends on a wide range of factors which - in some cases - correlate with each other. It is quite plausible that a combination of factors (e.g. flight behaviour, wind speed and relief of location) influences collision risk. As a consequence, it is very difficult to transfer the results obtained at a particular wind farm to another. At present, there is insufficient information available to form a reliable judgement on the scale of collision at a proposed wind farm.

1.2 Barrier Effect

There are several reliable studies indicating that wind turbines have a disturbing effect on birds and hence may act as barriers to bird movement.

At a wind farm (220 turbines) at the western bank of the Gulf of Suez, the behaviour of migrating birds was observed over a four-week period in spring 2007 (Bergen 2007). In the vicinity of the wind farm most birds (almost 88 %) used altitudes above 100 m, showed no clear reaction in presence of wind turbines and migrated over the wind farm. Most birds (over 83 %) migrating at altitudes below 100 m showed a clear reaction to the presence of wind turbines.

Black Kites most often increased altitude and subsequently entered the wind farm at heights above rotor blades but also at heights swept by the rotor. Thus, they passed over or through the wind farm. Some birds reacted to the presence of wind turbines with a combined vertical and horizontal behaviour. But change in flight direction alone was recorded relatively rarely. Accordingly, less than 11 % of all Black Kites did not pass the wind farm. In contrast, Steppe Buzzards did not change altitude in relevant numbers. The majority of birds changed their flight direction, so that they subsequently did not enter the wind farm area. Thus, Steppe Buzzards seem to regard the whole wind farm as a barrier. Consequently, Steppe Buzzards appear to be more sensitive to the presence of wind turbines, whereas Black Kites might be more vulnerable to collision.

The proportion of recordings of Black Kites changing altitude was markedly lower than the proportion of birds, indicating that birds migrating individually or in small flocks are less sensitive to the presence of wind turbines than flocks. The analysis of behaviour of Steppe Buzzards presents similar patterns.

Harriers usually migrated alone only a few meters above the ground. In the presence of wind turbines most Harriers showed no conspicuous reaction and simply flew through the wind turbines at heights below the rotor blades. A relevant number of birds (about 42 %) changed flight direction. As a consequence, one-third of migrating Harriers did not enter the wind farm area. Nevertheless, since the number of migrating Harriers was very low the findings must be treated with caution.

The results demonstrate that migrating birds were able to detect the presence of wind turbines and thus to react in an appropriate way depending on external (e.g. weather conditions) and internal (e.g. altitude, physical capabilities) factors. Birds at altitudes above 100 m simply migrated over the wind farm without any noticeable reaction. Birds at altitudes below 100 m became aware of the presence of wind turbines and apparently avoided them by changing their flight direction or increasing altitude. Sometimes birds seemed to avoid turbines in operation and purposefully approached a turbine not in operation and subsequently passed by.

A flight reaction of a bird in the vicinity of a turbine was recorded only twice. Irrespective of a bird's motivation (migrating, flying, hunting, resting) or of weather conditions, an appreciably irritated bird or a bird in a critical situation that might have led to a collision or to loss of flight control never occurred. Since the investigation refers to a rather short period, which did not cover the main migrating period of all species, results have to be verified.

A current study conducted at the wind farm La Venta II, which comprises 98 wind turbines and is located in the Isthmus of Tehuantepec in southern Mexico, has shown that migratory soaring birds adjust their flight paths suggesting a strong avoidance pattern during autumn migration and a possible avoidance pattern during spring migration (Cabrera-Cruz & Villegas-Patracá 2016, Villegas-Patracá et al. 2014). The observed avoidance behaviour indicates that the wind farm La Venta II is regarded as an obstacle. However, to date no study has provided proof for the hypothesis that a wind farm acts as a barrier that significantly hampers birds from migrating through a region.

During a 14-month study at a wind farm (66 turbines in a single row on top of a mountain ridge) near the Strait of Gibraltar, 72,000 migrating birds were recorded during about 1,000 hours of observation from fixed observation points (Janss 2000). The most abundant species were Black Kites, White Storks, House Martins (*Delichon urbica*) and Barn Swallows. Most of the migrating birds observed were passing over the wind farm, but at a higher average altitude than over two control areas. Average flight altitude at the wind farm was more than 100 m above ground. Almost 72 % of all soaring birds (n = 16,225) displayed changes in flight direction in the wind farm area (de Lucas et al. 2004, de Lucas et al. 2007). Raptors appeared to be accustomed to the presence of turbines and many birds flew close to turbines (de Lucas et al. 2004).

During a behavioural study at thirty seven study plots containing 277 turbines most birds (58.6 %) flew very low (< 5 m). 24.1 % of all birds showed panic behaviour in the risk zone, 20,3 % a sudden change of flight, and 15,6 % a slight change of flight (Lekuona & Ursúa 2007).

At the wind farm “Al Koudia” (84 turbines) in northern Morocco, autumn migration was observed over a three-month period in 2001 (El Ghazi & Franchimont 2001). Most birds (depending on species up to 100 %) showed clear avoidance behaviour in the presence of the turbines.

Further studies have shown that birds alter their routes to avoid flying through on- and offshore wind farms (e.g. Desholm & Kahlert 2005, Dirksen et al. 1998, Osborn et al. 2000). However, there are also locations where large numbers of birds regularly fly through wind farms without diverting around it (e.g. Everaert et al. 2002, Everaert & Stienen 2007).

Percival (2005) assumed that the ecological consequences of such a barrier effect are unlikely to be a problem at small wind farms. Drewitt & Langston (2006) suggest that none of the barrier effects identified so far have significant impacts on populations. However, under certain circumstances barrier effects might lead to population level impacts indirectly, e.g. where a wind farm effectively blocks a regularly used air route between nesting and foraging areas, or where several wind farms interact cumulatively. Then large wind farms or a number of wind farms might lead to increased energy expenditure for birds and thus might reduce annual survival rates and / or breeding output (Fox et al. 2006, Langston et al. 2006). In summary, until now it is quite difficult to judge whether avoidance behaviour causes a significant effect on individuals and, ultimately, on populations.

Strategic and Cumulative Environmental and Social Assessment Active Turbine Management Program (ATMP) for Wind Power Projects in the Gulf of Suez

Annex VII

“Sensitivity Search” by application of the Soaring Bird Sensitivity Map Tool (BirdLife International)





Soaring Bird Sensitivity Map: A planning tool for wind energy and other sectors

SEARCH SUMMARY

RCREEE

Results from Sensitivity Map

Countries: Egypt

Centroid: N28.552 E32.831 with no buffer

Combined Sensitivity: **Outstanding (8.606181502575055)**

19 soaring bird species observed while a further 11 soaring bird species are thought to occur in this area.

0 soaring bird observation locations.

1 IBAs supporting soaring birds plus a further 0 IBAs for non-soaring bird species.

1 protected sites.

11 satellite tracked migratory routes.

MAP

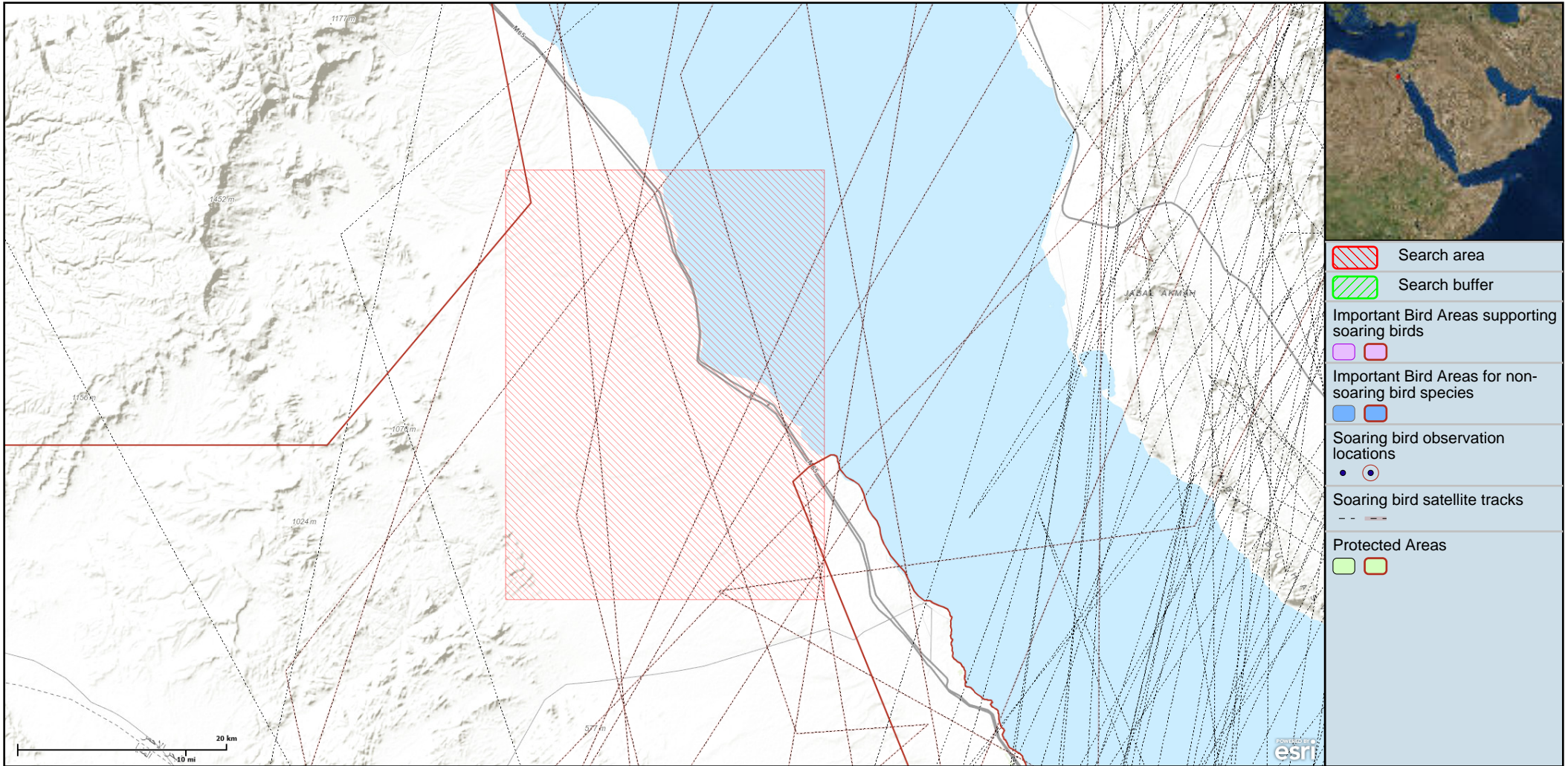



Soaring Bird Sensitivity Map: A planning tool for wind energy and other sectors

GUIDANCE ON INTERPRETING SEARCH RESULTS

For each search that a user performs, the tool calculates a sensitivity value based on the available soaring bird data and assigns the location to one of six sensitivity categories (defined in more detail below). This calculation takes into account the proportion of each species' global population present, the global conservation status (IUCN Red List) of each species and the inherent collision vulnerability of each species based on their morphology and flight behaviour.

Information for this region is incomplete and an appropriate Environmental Impact Assessments (EIA) should always be undertaken to fully assess the sensitivity of a site. Further information on the underlying methodology can be found in the Instructions section of the web tool.

Sensitivity category: UNKNOWN

There are insufficient soaring bird data on which to base a sensitivity score. This should not, however, be interpreted as meaning that a site has no or low sensitivity.

Sensitivity category: POTENTIAL

A small number of soaring bird records exist within the defined search area suggesting that the site could be sensitive.

Sensitivity category: MEDIUM and HIGH

Soaring bird species are known to be present in significant numbers. Caution advised as development at this location may result in significant impacts on the populations of species present. Development may not be appropriate at or near to this location or may be appropriate only if special mitigation measures are put in place.

Sensitivity category: VERY HIGH and OUTSTANDING

Soaring bird species are known to be present in very significant numbers. Caution advised as development at this location may result in considerable impacts on the populations of species present. Wind energy development is unlikely to be appropriate at or near to this location.

SPECIES (30)

Name	Peak Count	Presence	SVI	Status	Global population	Source
White Stork	250000	observed	10	LC	510000	IBA Population Data
Levant Sparrowhawk	7600	observed	6	LC	22500	IBA Population Data
Black Stork	1709	observed	10	LC	34000	IBA Population Data
Common Crane	15906	observed	10	LC	365000	IBA Population Data
Steppe Eagle	3159	observed	9	LC	160000	IBA Population Data
Egyptian Vulture	64	observed	10	EN	40500	IBA Population Data
Eastern Imperial Eagle	19	observed	9	VU	9250	IBA Population Data
Pallid Harrier	100	observed	8	NT	36000	IBA Population Data
European Honey-buzzard	8339	observed	7	LC	675000	IBA Population Data
Great White Pelican	1801	observed	10	LC	280000	IBA Population Data
Eurasian Buzzard	23539	observed	7	LC	4400000	IBA Population Data
Lesser Spotted Eagle	195	observed	9	LC	79000	IBA Population Data
Greater Spotted Eagle	1	observed	9	VU	9100	IBA Population Data
Black Kite	1660	observed	8	LC	2625000	IBA Population Data
Booted Eagle	118	observed	9	LC	253000	IBA Population Data
Short-toed Snake-eagle	95	observed	7	LC	170000	IBA Population Data



Soaring Bird Sensitivity Map:

A planning tool for wind energy and other sectors

SPECIES (30)

Name	Peak Count	Presence	SVI	Status	Global population	Source
Western Marsh-harrier	354	observed	8	LC	885000	IBA Population Data
Montagu's Harrier	86	observed	8	LC	540000	IBA Population Data
Lesser Kestrel	33	observed	6	LC	170000	IBA Population Data
Peregrine Falcon	-	expected	6	LC	500000	BirdLife species range map
Eurasian Hobby	-	expected	6	LC	1200000	BirdLife species range map
Lesser Kestrel	-	expected	6	LC	170000	BirdLife species range map
Osprey	-	expected	7	LC	750000	BirdLife species range map
Long-legged Buzzard	-	expected	7	LC	274000	BirdLife species range map
Sooty Falcon	-	expected	6	NT	22500	BirdLife species range map
Saker Falcon	-	expected	6	EN	32700	BirdLife species range map
Lanner Falcon	-	expected	6	LC	550000	BirdLife species range map
Bearded Vulture	-	expected	10	NT	6000	BirdLife species range map
Common Kestrel	-	expected	6	LC	8000000	BirdLife species range map
Red-footed Falcon	-	expected	6	NT	550000	BirdLife species range map



Soaring Bird Sensitivity Map:

A planning tool for wind energy and other sectors

SOARING BIRD IBAS (1)

Name	SI	Type	Source
Gebel El Zeit	Outstanding	IBA	Birdlife



Soaring Bird Sensitivity Map:

A planning tool for wind energy and other sectors

PROTECTED AREAS (1)

Name	IUCN Category	Status	Status Year
El-Galala El-Qebalya	Not Reported	Proposed	1999



Soaring Bird Sensitivity Map:

A planning tool for wind energy and other sectors

SATELLITE TRACKS (11)

Count	Species	Source
11	White Stork	Fiedler et al.



Soaring Bird Sensitivity Map:

A planning tool for wind energy and other sectors

SPECIES BY LOCATION

Name		SI				Type	Source	
Gebel El Zeit		Outstanding				IBA	Birdlife	
Name	Peak Count	SVI	Status	Year	Season	% of Global Population	Global population	Source
White Stork	250000	10	LC	1998	passage	49.02 %	510000	IBA Population Data
Levant Sparrowhawk	7600	6	LC	2007	passage	33.78 %	22500	IBA Population Data
Black Stork	1709	10	LC	2007	passage	5.03 %	34000	IBA Population Data
Common Crane	15906	10	LC	2007	passage	4.36 %	365000	IBA Population Data
Steppe Eagle	3159	9	LC	1994	passage	1.97 %	160000	IBA Population Data
Egyptian Vulture	64	10	EN	2007	passage	0.16 %	40500	IBA Population Data
Eastern Imperial Eagle	19	9	VU	1994	passage	0.21 %	9250	IBA Population Data
Pallid Harrier	100	8	NT	2007	passage	0.28 %	36000	IBA Population Data
European Honey-buzzard	8339	7	LC	2007	passage	1.24 %	675000	IBA Population Data
Great White Pelican	1801	10	LC	2007	passage	0.64 %	280000	IBA Population Data
Eurasian Buzzard	23539	7	LC	2007	passage	0.53 %	4400000	IBA Population Data
Lesser Spotted Eagle	195	9	LC	2007	passage	0.25 %	79000	IBA Population Data
Greater Spotted Eagle	1	9	VU	2007	passage	0.01 %	9100	IBA Population Data
Black Kite	1660	8	LC	2007	passage	0.06 %	2625000	IBA Population Data
Booted Eagle	118	9	LC	2007	passage	0.05 %	253000	IBA Population Data
Short-toed Snake-eagle	95	7	LC	2007	passage	0.06 %	170000	IBA Population Data
Western Marsh-harrier	354	8	LC	2007	passage	0.04 %	885000	IBA Population Data



Soaring Bird Sensitivity Map:

A planning tool for wind energy and other sectors

SPECIES BY LOCATION

Name		SI				Type	Source	
Gebel El Zeit		Outstanding				IBA	Birdlife	
Name	Peak Count	SVI	Status	Year	Season	% of Global Population	Global population	Source
Montagu's Harrier	86	8	LC	2007	passage	0.02 %	540000	IBA Population Data
Lesser Kestrel	33	6	LC	2007	passage	0.02 %	170000	IBA Population Data



Soaring Bird Sensitivity Map:

A planning tool for wind energy and other sectors

LOCATIONS BY SPECIES

Name	Peak Count	Presence	SVI	Status	Global population	Source
White Stork	250000	observed	10	LC	510000	IBA Population Data

Name	SI	Type	Source
Gebel El Zeit	Outstanding	IBA	Birdlife

Name	Peak Count	Presence	SVI	Status	Global population	Source
Levant Sparrowhawk	7600	observed	6	LC	22500	IBA Population Data

Name	SI	Type	Source
Gebel El Zeit	Outstanding	IBA	Birdlife

Name	Peak Count	Presence	SVI	Status	Global population	Source
Black Stork	1709	observed	10	LC	34000	IBA Population Data

Name	SI	Type	Source
Gebel El Zeit	Outstanding	IBA	Birdlife

Name	Peak Count	Presence	SVI	Status	Global population	Source
Common Crane	15906	observed	10	LC	365000	IBA Population Data

Name	SI	Type	Source
Gebel El Zeit	Outstanding	IBA	Birdlife



Soaring Bird Sensitivity Map:

A planning tool for wind energy and other sectors

LOCATIONS BY SPECIES

Name	Peak Count	Presence	SVI	Status	Global population	Source
Steppe Eagle	3159	observed	9	LC	160000	IBA Population Data

Name	SI	Type	Source
Gebel El Zeit	Outstanding	IBA	Birdlife

Egyptian Vulture	64	observed	10	EN	40500	IBA Population Data
------------------	----	----------	----	----	-------	---------------------

Name	SI	Type	Source
Gebel El Zeit	Outstanding	IBA	Birdlife

Eastern Imperial Eagle	19	observed	9	VU	9250	IBA Population Data
------------------------	----	----------	---	----	------	---------------------

Name	SI	Type	Source
Gebel El Zeit	Outstanding	IBA	Birdlife

Pallid Harrier	100	observed	8	NT	36000	IBA Population Data
----------------	-----	----------	---	----	-------	---------------------

Name	SI	Type	Source
Gebel El Zeit	Outstanding	IBA	Birdlife



Soaring Bird Sensitivity Map:

A planning tool for wind energy and other sectors

LOCATIONS BY SPECIES

Name	Peak Count	Presence	SVI	Status	Global population	Source
European Honey-buzzard	8339	observed	7	LC	675000	IBA Population Data

Name	SI	Type	Source
Gebel El Zeit	Outstanding	IBA	Birdlife

Great White Pelican	1801	observed	10	LC	280000	IBA Population Data
---------------------	------	----------	----	----	--------	---------------------

Name	SI	Type	Source
Gebel El Zeit	Outstanding	IBA	Birdlife

Eurasian Buzzard	23539	observed	7	LC	4400000	IBA Population Data
------------------	-------	----------	---	----	---------	---------------------

Name	SI	Type	Source
Gebel El Zeit	Outstanding	IBA	Birdlife

Lesser Spotted Eagle	195	observed	9	LC	79000	IBA Population Data
----------------------	-----	----------	---	----	-------	---------------------

Name	SI	Type	Source
Gebel El Zeit	Outstanding	IBA	Birdlife



Soaring Bird Sensitivity Map:

A planning tool for wind energy and other sectors

LOCATIONS BY SPECIES

Name	Peak Count	Presence	SVI	Status	Global population	Source
Greater Spotted Eagle	1	observed	9	VU	9100	IBA Population Data

Name	SI	Type	Source
Gebel El Zeit	Outstanding	IBA	Birdlife

Black Kite	1660	observed	8	LC	2625000	IBA Population Data
------------	------	----------	---	----	---------	---------------------

Name	SI	Type	Source
Gebel El Zeit	Outstanding	IBA	Birdlife

Booted Eagle	118	observed	9	LC	253000	IBA Population Data
--------------	-----	----------	---	----	--------	---------------------

Name	SI	Type	Source
Gebel El Zeit	Outstanding	IBA	Birdlife

Short-toed Snake-eagle	95	observed	7	LC	170000	IBA Population Data
------------------------	----	----------	---	----	--------	---------------------

Name	SI	Type	Source
Gebel El Zeit	Outstanding	IBA	Birdlife



Soaring Bird Sensitivity Map:

A planning tool for wind energy and other sectors

LOCATIONS BY SPECIES

Name	Peak Count	Presence	SVI	Status	Global population	Source
Western Marsh-harrier	354	observed	8	LC	885000	IBA Population Data
Name		SI		Type		Source
Gebel El Zeit		Outstanding		IBA		Birdlife
Montagu's Harrier	86	observed	8	LC	540000	IBA Population Data
Name		SI		Type		Source
Gebel El Zeit		Outstanding		IBA		Birdlife
Lesser Kestrel	33	observed	6	LC	170000	IBA Population Data
Name		SI		Type		Source
Gebel El Zeit		Outstanding		IBA		Birdlife
Peregrine Falcon	-	expected	6	LC	500000	BirdLife species range map
Eurasian Hobby	-	expected	6	LC	1200000	BirdLife species range map
Lesser Kestrel	-	expected	6	LC	170000	BirdLife species range map
Osprey	-	expected	7	LC	750000	BirdLife species range map
Long-legged Buzzard	-	expected	7	LC	274000	BirdLife species range map



Soaring Bird Sensitivity Map:

A planning tool for wind energy and other sectors

LOCATIONS BY SPECIES

Name	Peak Count	Presence	SVI	Status	Global population	Source
Sooty Falcon	-	expected	6	NT	22500	BirdLife species range map
Saker Falcon	-	expected	6	EN	32700	BirdLife species range map
Lanner Falcon	-	expected	6	LC	550000	BirdLife species range map
Bearded Vulture	-	expected	10	NT	6000	BirdLife species range map
Common Kestrel	-	expected	6	LC	8000000	BirdLife species range map
Red-footed Falcon	-	expected	6	NT	550000	BirdLife species range map



Soaring Bird Sensitivity Map:

A planning tool for wind energy and other sectors

DISCLAIMERS

BirdLife International makes no warranties or representations, express or implied, regarding the use of the material appearing on in this report with regard to its correctness, reliability, accuracy, or otherwise. The material and geographic designations in this report do not imply the expressions of any opinion whatsoever on the part of BirdLife International concerning the legal status of any country, territory or area, nor concerning the delimitation of its frontiers or boundaries. Neither BirdLife International nor its affiliated or related entities or its content providers shall be responsible or liable to any person, firm or corporation for any loss, damage, injury, claim or liability of any kind or character based on or resulting from any information contained in this report. BirdLife International may update or make changes to the data provided at any time without notice; however, BirdLife International makes no commitment to update the information contained therein.

Errors and Omissions

BirdLife International endeavours to maintain accurate and up-to-date data at all times. However, if errors or omissions are identified, the user should notify BirdLife International so that they can be corrected in future releases of the data. Users can contact BirdLife International using the details below. Users can contact BirdLife International at MSBtool@birdlife.org

